

Global anisotropy and theory of byuon

Yuriy Alexeevich Baurov^{1,2}

¹Closed Joint Stock Company Research Institute of Cosmic Physics, 141070, Moscow Region, Pionerskaya, 4, Korolyov, Russia

²Hotwater Srl, , Via Gioberti, 15, I-56024 San Miniato (PI), Italy

Email address:

baurov@mail.ru

To cite this article:

Yuriy Alexeevich Baurov. Global Anisotropy and Theory of Byuon. *American Journal of Astronomy and Astrophysics*. Special Issue: Global Anisotropy, Theory of Byuon, New Force, New Power System, Propulsion, Space Flights. Vol. 2, No. 6-1, 2014, pp. 1-7.

doi: 10.11648/j.ajaa.s.2014020601.11

Abstract: The basic ideas of an unconventional physical model of creation of the observed physical space and ultimate particles from a finite set of special discrete objects (byuons) are presented and discussed. The qualitative distinctions between the theory of byuons and previous physical theories are discussed. Predictions of theory of byuons are proposed: the existence of the cosmological vectorial potential A_g , a novel fundamental vectorial constant defining the global anisotropy of physical space, a new force of nature and the quantum information channel.

Keywords: Global Anisotropy, Theory of Byuon, Physical Space

1. Introduction

It was shown in [1–5] that with extraordinary variance in the action of a system of spinor and boson fields interacting with an electromagnetic field, the potentials of physical fields that are non-measurable from the standpoint of gauge theories, become unambiguous and measurable quantities within the space under study, due to violation of the gauge invariance within the area of electric charge variation. The variance is unusual in that the speed of interaction propagation $C(x, t)$, where x is a certain space coordinate and t is time, is assumed to be a generalized coordinate, the electric charge is a function of such generalized coordinate $e = e\{C(x, t)\}$ and the static properties of the fields are fixed.

In this article we'll briefly explain the foundations and basic results dealt with in [1-5] and the very important consequences leading to a new unconventional physical model of creation of the observed physical space and ultimate particles from a finite set of special discrete objects, the byuons, in turn defined on the basis of the cosmological vectorial potential A_g — a novel fundamental vectorial constant representing the global anisotropy of the physical space. The qualitative distinction between the theory of byuon (TB) and previous physical theories, along with the predictions arising from the TB will be shown.

2. Forerunners or a New Approach to Quantum Field Theory in the Mid-1980's

The equations of motion are commonly presented for any system in the Lagrange-Euler form, usually obtained from the principle of least action, provided that $\delta q \Big|_{\Omega_1}^{\Omega_2} = 0$ (q is an

arbitrary generalized coordinate). As a result, the Lagrangian (L) is an ambiguous function in the ordinary treatment, and is determined within the precision of some four-dimensional vector divergence, for example, of derivatives $\frac{\partial}{\partial x^n} \left(\frac{\partial L}{\partial q_n^i} \delta q^i \right)$,

where $q_n^i = \frac{\partial q^i}{\partial x^n}$. This is understandable since, according to Gauss theorem,

$$\int_{\tilde{V}} \frac{\partial}{\partial x^n} \left(\frac{\partial L}{\partial q_n^i} \delta q^i \right) d\tilde{V} = \int_{\Omega_2} \frac{\partial L}{\partial q_n^i} \delta q^i d\Omega - \int_{\Omega_1} \frac{\partial L}{\partial q_n^i} \delta q^i d\Omega$$

On condition that $\delta q \Big|_{\Omega_1}^{\Omega_2} = 0$, the surface integrals become zero and do not contribute to Lagrange-Euler equations.

Thus, the condition $\delta q \Big|_{\Omega_1}^{\Omega_2} = 0$, allowing obtaining said equations, restricts the class of motion equations of a system.

Let us derive the equations of motion for an arbitrary

system without the condition $\delta q \Big|_{\Omega_1}^{\Omega_2} = 0$.

It should be noted that if restrictions are imposed on q_i and, hence, δq_i may be nonzero at the boundary of volume \tilde{V} , one could use, in such a case, results of non-classic variation calculus and the Pontryagin's maximal principle [2, 6]. According to that, with q_i imposed on by inequalities $-q_0^i \leq q^i \leq q_0^i$, the optimum values, from the viewpoint of minimum S , should be $q_i = -q_0^i$ and $q_i = q_0^i$.

But we try to act in a different way, presenting δS in the following manner

$$\delta S = \int_{\Omega_1}^{\Omega_2} \left(\frac{\partial L}{\partial q^i} \delta q^i + \frac{\partial L}{\partial q_n^i} \delta q_n^i \right) d\tilde{V} = \int_{\Omega_1}^{\Omega_2} \left(\frac{\partial L}{\partial q^i} + \frac{\partial L}{\partial q_n^i} \frac{\delta q_n^i}{\delta q^i} \right) \delta q^i d\tilde{V} \quad (1)$$

If the ratios $\delta q_n^i / \delta q^i$ in (1) do not contain variations of parameters, we arrive, according to the basic lemma of variation calculus [7], to the equation:

$$\frac{\partial L}{\partial q^i} + \frac{\partial L}{\partial q_n^i} \frac{\delta q_n^i}{\delta q^i} = 0 \quad (2)$$

For the case above, this equation is more general than that of Lagrange-Euler. An analogous equation has also been obtained in [8] after a series of extensive special transformations. Basing on the action of a system of spinor and boson fields interacting with an electromagnetic field and the equation (2) we got the fundamental constants: elementary electric charge (e_0) and Planck's constant (h) through some parameters: $|\vec{A}| = |A| \approx 1.95 \cdot 10^{11} \text{Gs} \cdot \text{cm}$; $x_0 \approx 10\text{-}17 \text{cm}$; $ct^* \approx 10\text{-}13 \text{cm}$ (Table 1). One of the main results of works [1 - 5] is that the expressions obtained for elementary particle masses appear to be proportional to the modulus of a certain vector potential A . In these works, such potential is referred to as the cosmological vector potential A_g [5].

Let us make some explanations.

In order to understand the origin of charges [4,5] and, particularly, the electric charge, the author was forced to use variation of $e(x,t)$. On the whole, it was natural since without changing a "subject" of investigation one cannot understand its structure. As a result, however, we had to give up the known classic symmetries, gauge invariance, relativistic invariance, and space-time translations, for investigation of characteristics of the electromagnetic field in a local region of volume x_0^3 .

Let us evaluate a value of our "error". According to the gauge invariance, the field systems $\bar{\psi}(\vec{r}, t)$, $\psi(\vec{r}, t)$, $A_n(\vec{r}, t)$,

and $e^{-ie\alpha(\vec{r}, t)} \bar{\psi}(\vec{r}, t)$, $e^{-ie\alpha(\vec{r}, t)} \psi(\vec{r}, t)$, $A_n(\vec{r}, t) + \frac{\partial}{\partial x_n} \alpha(\vec{r}, t)$

describe the same physical pattern, i.e. the equations have an identical form. Yet, it is known that the Dirac's equation for the free electron is not invariant relative to local gauge transformations, since it is necessary for invariance that an electromagnetic compensating field be existing, which is commonly assumed to be absent for the free electron.

In our approach, the local phase transformation of field

function $e^{ie\alpha(\vec{r}, t)} \psi(\vec{r}, t)$ for Dirac's free equation with conserving gauge invariance just indicates that fundamental potential A_0 and A must exist to compensate the phase change of the field.

Evaluate the compensating field of the vectorial potential from condition of invariance of Dirac's free equation relative to the following local phase transformation of field functions

$$e^{i(e(x,t)/e_0)} \psi(\vec{r}, t) \quad (3)$$

The charge e is assumed to be formed in the one-dimensional space for the electromagnetic field, with $e=e(x,t)$ where x is some size.

Write the Dirac's equation for electron in Minkowski space-time

$$[i\gamma_\mu \partial_\mu - m_e] \psi = 0 \quad (4)$$

The equation (4) is invariant relative to the transformations (3) when it's considered that there exists a vector \vec{A} originating from cosmic sources, which acts on $e(x,t)$ in the process of charge formation (PCF), and that there remains in the one-dimensional region x only one equation from the four (4).

Hence we have:

$$c\hbar \frac{\partial}{\partial x} \frac{e(x,t)}{e_0} = e(x,t) / \vec{A} \quad (5)$$

Since PCF occurs in the region with a characteristic size x_0 [4,5], x cannot be less than x_0 for the field $\psi(x,t)$ with the charge e .

From Eq.(5) we have $c\hbar/e_0 = x_0 / \vec{A} = \text{const}$. This constant value differs from that of x_0 / \vec{A} obtained using (2) (Table 1) by a factor of nearly 30 because of linearity of Eq.(4) and neglecting PCF when deriving this equation, since PCF is a substantially nonlinear process.

3. Theory of Byuon

The expressions for the Planck's constant and value of electric charge, given in Table 1 and "Conclusions and Summary of Basic Formulas" of Chapter 1 in [5], are invariant relative to variation of the parameters $|\vec{A}|$, x_0 , ct^* in the following relationships:

$$|\vec{A}| x_0 = \text{const1} \quad (6)$$

$$x_0 / ct^* = \text{const2} \quad (7)$$

Hence, when varying, for example, x_0 and ct^* so that the ratio (7) is always equal to const2 , the expressions for h and e_0 in above-mentioned "Conclusions" in [5] and Table 1 will remain unchanged. Similar is the situation with the parameters $|\vec{A}|$ and x_0 in Eq.(6).

Thus, we arrive to a conclusion that in nature may exist a certain set of earlier unknown objects determined by the product $\vec{A} x_0$ which our world is based on, since its

fundamental properties, particularly electromagnetic ones (e^2/hc is the constant of the thin structure) determined by such constants, such as h, e, c , remain unchanged on this set.

Table 1. Basic results of byuon theory.

Given	Obtained
	The fundamental scales: $x_0 = k \tilde{x}_0 \approx 10^{-17}$ cm; $ct^* = kN \tilde{x}_0 \approx 10^{-13}$ cm; $L = kNP \tilde{x}_0 \approx 10^{28}$ cm; k, N, P - calculated periods of interaction of byuons [5,13].
	The fundamental constants: speed of light $c_0 = \tilde{x}_0 / \tau$, the elementary electric charge $e_o^2 = (1/4\sqrt{3})A_g^2 x_o^2 (x_o/ct^*)^{3/2}$
The quantum of space $\tilde{x}_0 \approx 2.8 \cdot 10^{-33}$ cm.	Planck's constant $h = (([A_g x_o]_{II} + [A_g x_o]_{I})/c_o) x_o / ct^*$ [4,5,13]. The constants of all interactions, for example, vector constant of weak interaction $C_v = e_o A_g 2x_o^3$ [1,5,13].
The quantum of time $\tau \approx 0.9 \cdot 10^{-43}$ s.	Mass spectra of leptons (electron, muon, tau-lepton asf.), main barions, and mesons, for example, the mass of electron: $m_e c^2 = m_{4b} c^2 (ct^*/x_o)$; the minimum value of that residual potential energy :
The module of cosmological vector-potential A_g . $A_g \approx 1.95 \cdot 10^{11}$ G·cm	$E_{k_{min}}^0 = (A_g^2 \tilde{x}_0^2) / (2\tilde{x}_0) = m_{4b} c^2 = 33$ eV [5,13]. The density of matter in the Universe $\sim 10^{-29}$ g/cm ³ (physics of dark matter); physics of dark energy on the base of new force [15]; nature of quantum mechanics and quantum information channel [5,7, 16-19]; equations of electromagnetic field [5,20], value of galactic and intergalactic magnetic fields [5,13], asf.

In connection with the above said, the following model of structure of the physical space was first proposed in [5, 9.10].

Let us discuss this model (TB).

Any theory begins with axioms, that is, with basic postulates accepted without proof.

Thus, let us assume that there are no space, no time, no world of elementary particles from which all physical bodies surrounding us consist, but there is an object, a byuon $\Phi(i)$, being unobservable in itself and characterized by discrete states (i.e. numbered by the series of natural numbers) having inherent "vectorial" property. The expression for $\Phi(i)$ is

$$\Phi(i) = \begin{cases} [A_g x(i)], \\ -\sqrt{-1} [A_g x(i)] \end{cases} \quad (8)$$

where $x(i)$ is "length" of the byuon, a real (positive or negative) value depending on the index $i = 0, 1, 2, \dots, k, \dots$. Index i is a quantum number for $\Phi(i)$ ¹. The value of A_g is some inner potential equal, in magnitude, to the cosmological vector-potential A_g , a novel fundamental vectorial constant introduced by the author in Refs. [1,5,9,10]. It is not an ordinary potential of any field theory since we have yet no notions of field and its potential. We have to do with a special property of the byuon that we call therefore the inner

byuon potential. The dimensionality of $x(i)$ is that of distance, so we will measure $x(i)$ in centimeters (cm), and A_g in Gauss centimeter ($A_g \approx 1.95 \cdot 10^{11}$ G·cm). That is, our fundamental object is dimensional. That was presumed by many authors which searched for so called "universum" (that thing from which all the other things are built up), since the real world cannot be constructed from the dimensionless 0 and 1. But the question of dimensionality of that object remained an enigma. Our object, the byuon, has dimensionality of G·cm², as also have (in CGSE-system) such physical objects as electric charge, magnetic flux, and Dirac's monopole [11] a hypothetic object not yet detected in experiments.

The value $\Phi(i)$ is, by definition, real or truly imaginary (8). The entire set of states $\Phi(i)$ can form a one-dimensional space R_1 relative to index i . In R_1 , the distance between byuon states (in scientific language, the metrics) is defined as the difference of their "lengths", i.e. between quantities $x(i)$. Such a metrics is known as Archimedean metrics.

Let's explain the above said. If, for example, the object $\Phi(i)$ has, in one of its states, an enormous magnitude of $x(i)$ equal to 10^{28} cm, and in its another state, $x(i+k)$ is equal to that same enormous magnitude of 10^{28} cm plus 1 cm, then the distance between those states in the one-dimensional space R_1 will be an insignificant 1 cm.

Further, the notion of time is introduced. In accordance with our conception, by the discrete time of byuon is meant a sequence of events corresponding to discrete changes in index i of 1 up or down, which means a transition from one state to another. In connection with discrete time, a time quantum τ_0 and space quantum \tilde{x}_0 are introduced in the one-dimensional discrete space R_1 formed by states of byuon ($\tau \approx 0.9 \cdot 10^{-43}$ s, $\tilde{x}_0 \approx 2.8 \cdot 10^{-33}$ cm). As R_1 is discrete, one way to parametrize (represent) $x(i)$ is $x(i) \approx \tilde{x}_0 \cdot i$ or $x(i) \approx -\tilde{x}_0 \cdot i$. As is seen, the magnitude of $x(i)$ can be both positive and negative. Similar parameterization for time $t = (\tau_j)$ gives only positive magnitudes of t (here t is an always increasing index taking only integer positive values and the number 0). Note that in the existing physics of elementary particles [12], a notion of negative time is used to introduce antiparticles. This is not necessary in the present model.

Thus the byuon is characterized by indexes i and j ($i \leq j$). We will consider only the case of $i = j$.

Statics. In the set $\{\Phi(i)\}$, no static states with time $t > \tau_0$ are meant. That is, the byuon is always in state of continuous changing.

Kinematics. A free byuon state (that is, not interacting with another state) can correspond only to one of four so called vacuum states (VS) II+, I+, I-, II- depending on whether the vector $\Phi(i)$ is real or imaginary, its length $X(i)$ positive or negative, decreases or increases in modulus.

Let's introduce the following definitions:

1. The free byuon is in vacuum state II+ if its positive length discretely increases by a quantum of distance \tilde{x}_0 in a quantum of time τ_0 . At that, the speed of byuon propagation (increasing in length) is given by

$$c = \frac{\tilde{x}_0 - 0}{\tau_0} = c_0 \quad (c_0 \text{ is speed of light}).$$

¹ It should be explained that the vector $\Phi(i)$ is not an ordinary vector in some space but an object with "inner" vectorial properties that are manifesting themselves when the value $x(i)$ changes in the process of physical space formation.

2. The free byuon is in VS I^+ if its length discretely decreases by a quantum of distance \tilde{x}_0 in a quantum of time τ_0 . In this case $c = \frac{0 - \tilde{x}_0}{\tau_0} = -c_0$.
3. The free byuon is in VS II^- if the modulus of its negative length discretely increases by \tilde{x}_0 in a time τ_0 . Therewith $c = \frac{-\tilde{x}_0 - 0}{\tau_0} = -c_0$.
4. The free byuon is in VS I^- if the modulus of its negative length discretely decreases of \tilde{x}_0 in a time τ_0 . In this case $c = \frac{0 - (-\tilde{x}_0)}{\tau_0} = c_0$.

Location of byuon in one or another VS is of probabilistic character and described by four Ψ -functions with indexes corresponding both to VSs and magnitudes of quantum number i : $\Psi_{II^+}^{i+2}, \Psi_{II^-}^{k-i}$, determining the processes of byuon length magnitude origin and increase at positive and negative $X(i)$, respectively; $\Psi_{I^+}^i, \Psi_{I^-}^{k-i-2}$, determining the processes of byuon length magnitude cancellation and decrease at positive and negative $X(i)$, respectively.

Let's assume that for the byuons with the length greater than \tilde{x}_0 , only contact interactions are realized, by which we will mean existence of at least two byuons at a quantum of space R_1 (one-dimensional space).

Hypothesis 1. Assume the observable three-dimensional space R_3 to appear as a result of minimization of the potential energy ($E(i)$) of byuon interaction in the one-dimensional space R_1 formed by them. More precisely, the space R_3 arises

$$\begin{aligned} \cos_{I^+II^+}^{i,i+2} &= \cos_{I^-II^-}^{NkP-i-2, NkP-i} = \cos_{I^-II^-}^{NkP-i-2-2, NkP-i-2} = \cos_{I^-II^-}^{NkP-i-2-2 \times 2, NkP-i-2 \times 2} = \dots; \\ \cos_{II^-II^-}^{NkP-i-k, NkP-i} &= \cos_{II^-II^-}^{NkP-i-2k, NkP-i} = \dots; \end{aligned}$$

The functions $\cos_{II^+I^-}, \cos_{II^-I^+}$ are considered as equal to 1. Initial conditions for Ψ -function are preset to be

$$\Psi_{II^+}^0 \approx 0, \Psi_{I^+}^0 \approx 1, \Psi_{II^-}^{NkP} \approx 1, \Psi_{I^-}^{NkP} \approx 0, \Psi_{I^+}^1 \approx \Psi_{I^-}^{NkP-2}, \Psi_{II^-}^{NkP-1} = \Psi_{II^+}^2, \Psi_{I^-}^{i+2} + \Psi_{I^-}^{i+1} = 0$$

Now, taking into account the normalizing expressions (see [5,13]), let's seek for $\min \Delta E(i)$ by the steepest descent method. When retaining only 14 terms of the series, $\min \Delta E(i)$ will correspond to the following values:

$$\begin{aligned} \Psi_{I^+}^0 &= 0.999(6), \Psi_{II^+}^2 = 1.00136 \times 10^{-4}, \Psi_{II^-}^{NkP} = 0.999(8), \\ \Psi_{I^-}^{NkP-2} &= 1.100043 \times 10^{-4}, \cos_{I^+II^+}^{i,i+2} = 1.01887 \times 10^{-5}, \\ \cos_{II^-II^-}^{NkP-i-k, NkP-i} &= 1.20013 \times 10^{-5}, k = 6.2 \times 10^{15}, NkP = 3 \times 10^{60} \end{aligned} \quad (10)$$

With increasing n , as is seen from the solutions given in [5,13], k (the first period in i) approaches its value obtained in [3,14] on the base of physical considerations as an integer part of the ratio $x_0/\tilde{x}_0 = 3.2 \times 10^{15}$. Thus, we can now obtain, with the aid of the calculated k , one of the fundamental dimensions in physics of elementary particles, $x_0 \approx 10^{-17}$ cm, with the only quantum of space \tilde{x}_0 given. This mathematical result raises prospects that the advanced hypothesis is true. It reflects the nature of physical space and

as the result of this byuon dynamics. In the space R_3 therewith the dynamic processes for objects with the residual positive potential energy of byuon interactions originate and, in consequence, the wave properties of elementary particles arise.

The potential energy ($E(i)$) is a very big set [5,13].

The minimization of $\Delta E(i)$ is achieved in the functional space of the following variables:

$$\Psi_{I^+}^0, \Psi_{II^+}^2, \Psi_{II^-}^{NkP}, \Psi_{I^-}^{NkP-2}, \cos_{I^+II^+}^{i,i+2}, \cos_{II^-II^-}^{NkP-k-i, NkP-i}, k, NP \quad (9)$$

The first four coordinates in (9) are the initial conditions for Ψ -function; $\cos_{I^+II^+}, \cos_{II^-II^-}$ etc. are functions minimizing the potential energy of interaction of byuons entering into the expressions for $E_{I^+II^+}^{i,i+2}, \dots, E_{I^-II^-}^{NkP-i-2, NkP-i}$, etc.; these functions are "responsible" for the appearance of a minimum plane object and the introduction of the concept of spin and any rotation [5,13]. The probability of a single event is no greater than 1. Depending on which range is i in ($0 \leq i < k, k < i < Nk, Nk < i < NkP$ where k, N, P are the assumed periods in i) various types of contact interactions between byuons may be introduced, and hence the normalization of the introduced functions should be dependent on i (for details, see [5,13]).

It is assumed therewith that the conditions of symmetry during the "closure of the loop" in i are fulfilled as well as the symmetry of the world and anti-world, which conditions can be represented as:

vacuum. The distance $L = kNP \tilde{x}_0 \approx 10^{28}$ cm is a scale of our Universe. The distance $ct^* = kN \tilde{x}_0 \approx 10^{-13}$ cm is defined using the theorem for informational units (bits) in the subspaces R_1 and R_3 [5,13].

Note that the known fundamental constant, light speed, appears in the byuon theory as a result of byuon changes. In what follows the reader will know that, when having specified only three constants: modulus of A_g , τ_0 , and \tilde{x}_0 , we obtain values of all other fundamental constants and basic properties of the entire world as well (Table 1 and [2, 3]).

The most important point of Universe is its stability. Therefore, for example, for stable particles (electron, proton) of our world, byuon with VS I^+ has a probability close to 1. That is, the entire information coming out of this space region is fully closed by the indicated VS in the said region of space R_3 . In Fig. 1 the described pattern is qualitatively shown. The filled loop with characteristic dimension x_0 has VS I^+ at the outlet and does not let out any information

connected with the process of extension of byuon VS II⁺ with velocity c_0 .

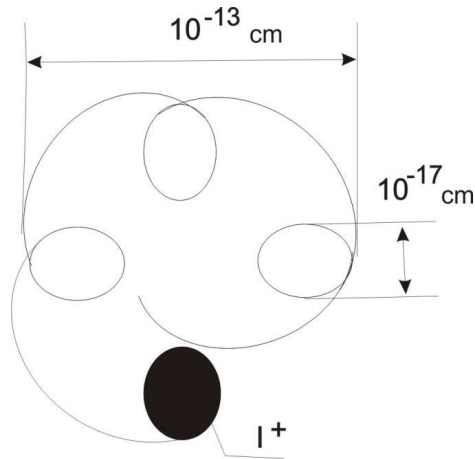

Fig 1. The crosshatched loop with characteristic dimension x_0 has VS I⁺ at the outlet and does not let out any information connected with the process of extension of byuon VS II⁺ with velocity c_0 .

4. The Discussion and Predictions of Theory of Byuon

It is known that any novel physical model of the Universe must meet the following criteria. First, all the discovered laws of nature as well as sufficiently well established models of one or another physical phenomena must follow from the new model as asymptotical approximations. Second, the new theory should have the capability for prediction. That is, it should guide an experimental way to the gain of new knowledge, as the theory itself gives nothing but only points such a way. Criterion of truth is an accurately performed experiment independently confirmed by various authors. The theory of byuons [5, 13] seems to meet the above criteria. The intrinsic dynamics of byuons determines such fundamental phenomena as the course of time, physical space, rotation of planets and stars, spins of elementary particles, asf. (Table 1 and [5,13]).

What is a qualitative distinction between the theory of byuons and previous physical theories? In this special issue we will not consider in detail present-day physical conceptions. The structure of space and time, physical sense of these fundamental notions and their properties, as well as physics of elementary particles in that the mentioned notions may deviate from the accepted standards, are dealt with in a great deal of works, from antiquity (Aristoteles [21], Euclidean “Principia”, Democritean “world’s tiny bricks”) to authors of twentieth century. Only a review of published works on physics of elementary particles could entirely occupy this special issue. Therefore we advise the reader to acquaint himself if only with two monographs [22, 23]. In the first of them, a physical and philosophic comprehension on hundreds of works on the above stated questions is given. The second, an original book of the known soviet physicist D.I. Blokhintsev, describes difficulties in creating a modern theory of space, and especially of the world of elementary

particles.

Let’s return to the matter of the qualitative distinction of the theory of byuons.

First, the physical space was always given in all the science, in one way or another, and motion equations for a system of objects under study were written in that space. Space could be uniform continuum (Newton, Minkovsky) or discrete, one-dimensional or multidimensional, asf. In present-day cosmologic models of the Universe origin (Gamov’s Big Bang [24], Linde’s model of bulging Universe [25], and so on), space is always given, too. In the theory of byuons, the physical space (necessarily three-dimensional one, not ten-or-more-dimensional as in modern physical models) is a special quantized medium arising as the result of interaction of byuon’s vacuum states (VSs). That is, space is not given but arises. Therewith the appearing three-dimensional space must have a marginal global anisotropy, as distinct from all basic isotropic models with the same properties in any directions. The said anisotropy denotes the existence of some chosen direction caused in turn by the existence, in nature, of a new fundamental vectorial constant, the cosmological vector-potential A_g entering into the definition of the byuon. That new constant is associated with the prediction of a novel anisotropic interaction of natural objects among themselves and with the physical vacuum, a lowest energy state of physical fields. The TB suggest an opposite idea of *arising* Universe with regards to modern models based upon supersymmetry [26-31] (symmetry \rightarrow spontaneous violation of symmetry \rightarrow *mass*) because TB has at first a strong anisotropy (space R_1) and later on a practically symmetric R_3 space with very small residual anisotropy (on the order, in the space without particles, of 10^{-15} , inside the particles on the order of 10^{-5}).

It should be noted that in the literature spaces with local rather than global anisotropy are considered [32], for example the Finsler’s space-time [33], but the local anisotropy is given therein “by hand”, as the saying goes. That is, an author himself directly introduces it into his model instead of obtaining it from some general principles.

Secondly, the physical sense of time notion is not yet revealed in science at the present state of the art [34]. The general philosophic concept of time as a form of matter existence, which form expresses the order of change of objects and phenomena as a sequence of events, does not indicate a common nature of those events. As a rule, people tie their time to a particular periodic process: rotation of the Earth around its axis, Earth’s orbiting around the Sun, oscillations of a quartz system, asf, without becoming aware of inner, profound sense of time. Standard physical time references, for example, quantum or, what is the same, atomic clock with instrument error on the level of 10^{-11} per year and moderate resolution on the order of 10^{-13} seconds, give us no possibility of approaching the knowledge of time essence. The TB reveals physical essence of time as a discrete sequence of changes in the byuon’s “length”, its quantum number. A possibility therewith arises, to synchronize clocks at great distances comparable with

dimensions of our Metagalaxy, due to the quantum process of physical space formation from the byuon's vacuum states. That possibility substantially distinguishes the theory of byuon from A. Einstein's special theory of relativity (STR), in which clocks can be synchronized only when a signal has passed between them with speed of light c . It should be noted at once that in the TB, material objects cannot move faster than light (that is similar to the STR's postulate on finite propagation velocity of interactions), but synchronization of clocks occurs by a quantum way without introducing the concept of speed. That is, some object originated in the course of interaction between byuon VSs and forming the physical space, is at a time in two spatial regions being very distant from each other in the arising three-dimensional space.

Third, an essential distinction of the TB from modern models in the classical and quantum field theories [35] is that the potentials of physical fields (gravitational, electromagnetic, asf.) become, in the theory of byuons, exactly fixable, measurable values. We recall to the reader that ordinary methods of measurement are capable to measure solely a difference of potentials. Therefore, in the existing field theory, potentials are defined only within the precision of an arbitrary constant, or the rate of change of the potentials in space or time. But in the TB field potentials become single-valued since, on the set of byuon VSs, field charge numbers there are formed, which generate the fields themselves, such as, for example, the electric charge of an electron generates an electric field. The physical sense of field as a special form of matter, loses its basic meaning because all the observable events can be described on the basis of the TB without introducing the concept of force, and hence of field too, instead using changes of fundamental scales (Table 1, [5,13]).

An important methodic distinction between the byuon model and all those existent in the current theoretical physics, is that the latter use images with properties of real objects, for example strings in the physics of elementary particles [30], superstrings [28], membranes when creating a unified field theory, asf. On the contrary, byuons are unobservable objects having no analogues in the nature though all the natural objects appear as the result of interaction of byuon VSs.

Having explained the distinctive peculiarities of the byuon theory, let's notice that in this special issue, results of some new fundamental experiments in support of the basic theoretical statements will be shown. There will be also given some results of a run of applied investigations opening up entirely new horizons as to further development of our civilization in the areas of power engineering and information. Quite an inexhaustible source of power associated with the energy of the observable physical space (physical vacuum) and physical space of elementary particles, is opening up. That energy is one order of magnitude greater than all the energy stored in substance of our Universe. Peculiar "cocks" to gain new energy are elementary particles because a fraction of their masses (33eV) is proportional to the modulus of some summary potential A_{sum} that contains

potentials of all known fields. A_{sum} cannot be larger than the modulus of A_g . By means of those potentials, we can affect the process of forming, from VSs of byuon, this fraction of the mass of elementary particles associated with formation of their geometric space, with probability close to 1, and gain energy according to the known A. Einstein's formula $E=mc^2$. Thus, a new interaction of objects with physical vacuum arises, which interaction forces substance out of a region with weakened summary potential.

The greater part of the author's publications is dedicated just to studying that summary potential as well as using its properties. The new interaction and quantum properties of physical space predetermine the existence of a previously quite unknown quantum information channel (QIC) for communication of objects of the Universe through objects forming the physical space. This communication channel allows transmitting information between objects in the Universe by a quantum way without delay.

5. Conclusion

The main predictions of TB are: the existence of the cosmological vectorial potential A_g , i.e. a novel fundamental vectorial constant defining the global anisotropy of physical space, a new force of nature and the QIC. These predictions were confirmed by a large number of fundamental experiments [5, 13].

After reading the special issue, the reader will know a practical using of TB: how new vehicles can use the new force as tractive force; how one can, by such vehicles, pioneer interstellar distances beyond the limitation imposed by the local reaction principle (local momentum conservation); how thermal energy can be generated with very high efficiency using some consequences of the byuon theory, asf.

References

- [1] Yu.A. Baurov, Yu.N.Babaev and V.K.Ablekov, Dokl. Akad. Nauk SSSR, vol. 259, no. 5, p. 1080, 1981.
- [2] Yu.A. Baurov, Yu.N.Babaev and V.K.Ablekov, Dokl. Akad. Nauk SSSR, vol. 262, no. 1, p. 68, 1982.
- [3] Yu.A. Baurov, Yu.N.Babaev and V.K.Ablekov, Dokl. Akad. Nauk SSSR (DAN), vol. 265, no. 5, p. 1108, 1982.
- [4] Yu.N.Babaev, and Yu.A. Baurov, On the Origin of Fundamental Constants and Some Quantum Numbers, Preprint of Institute for Nuclear Research of the USSR Academy of Sciences, no. P-0362, 1984.
- [5] Yu. A. Baurov "On the Structure of Physical Vacuum and a New Interaction in Nature (Theory, Experiment and Applications)", Nova Science, New York, 2000.
- [6] L.S.Pontryagin et al., Mathematical theory of optimum processes, Moscow, "Nauka", 1969 (in Russian).
- [7] L.E. Elsgolz, Differential equations and variation calculus, Moscow, "Nauka", 1969 (in Russian).

- [8] K.P.Stanyukovich, in "Theory of relativity and gravitation", Moscow, "Nauka", 1976 (in Russian).
- [9] Yu.A.Baurov, in coll. work "Plasma physics and some questions of the General Physics", Central Institute of Machinery, Moscow region, Kaliningrad, pp.71,84, 1990, (in Russian).
- [10] Yu.A.Baurov, Fizicheskaya Mysl Rossii, No1, p.18, 1994, (in Russian).
- [11] P.A.Dirac. Ways of Physics, Moscow, "Energoatomizdat", 1983 (in Russian).
- [12] N.F.Nelippa, Physics of elementary particles, Moscow, "VysshayaShkola", 1977 (in Russian).
- [13] Yu.A. Baurov, Global Anisotropy of Physical Space.Experimental and Theoretical Basis, New York: Nova Science., 2004.
- [14] Yu.N.Babaev, Yu.A.Baurov, Preprint P-0362 of INR RAS, Moscow, 1985 (in Russian).
- [15] Yu. A. Baurov, I. F. Malov, Journal of Modern Physics, 1 (2010) 17-32; *ArXiv*: 0710.3018v1 [physics. gen.-ph] (2007).
- [16] Yu.A.Baurov et. al., Biophysics, v.46, n.5, p.781, 2001.
- [17] [17.] Baurov Yu.A. et. al., International Journal of Scientific Research., vol.16, pp.469-473, 2006.
- [18] Yu. A. Baurov, Byuons, Quantum information channel, consciousness and Universe, Open Journal of Microphysics, 1, pp. 35-39, 2011.
- [19] Yu.A. Baurov «Structure of Physical Space and Nature of de Broglie Waves (Theory and Experiment)» Jornal "Annales de Fondation de Broglie" "Contemporary Electrodynamics", v.27, n3, p. 443-461, 2002.
- [20] Yu.A. Baurov, Structure of physical space and nature of electromagnetic field, in coll. Work. PHOTON: Old problems in light of new ideas, Nova Science, NY, 2000, p. 259-269.
- [21] Aristoteles, v.3, Moscow, "Mysl", 1981 (in Russian).
- [22] A.N.Vyaltsev, The discrete space-time, Moscow, "Nauka", 1965 (in Russian).
- [23] D.I.Blokhintsev, Space and time in the microworld, Moscow, "Nauka", 1982 (in Russian).
- [24] R.A.Alpher, M.Bethe, G.Gamov, Phys. Rev., v.70, p.572, 1946; i bid: 1948, v.73, p.803.
- [25] A.D.Linde, UspekhiFizicheskikh Nauk (UFN), v.144, p.177, 1984.
- [26] J.Scherk, T.H.Schwarz, Phys.Lett., Ser.B., v.57, p.463, 1975.
- [27] E.Cremmer, J.Scherk, Mod.Phys., Ser.B., v.103, p.393; v.108, p.409, 1976.
- [28] J.H.Shwartz, Superstrings, Singapore, "World Scientific", 1985.
- [29] J.H.Schwarz, Phys.Rept., v.89, p.223, 1982.
- [30] M.B.Green, Surv. High Energy Phys., v.3, p.127, 1983.
- [31] B.M.Barbashov, V.V.Nesterenko, UFN, v.150, p.489, 1986.
- [32] G.Yu. Bogoslovsky. Theory of locally anisotropic space-time. Ed. by Moscow State University, 1992 (in Russian).
- [33] RundKh. Differential geometry of Finsler's spaces. Moscow, "Nauka", 1981.
- [34] Time structures in natural sciences: on the road to right understanding of time phenomenon. Part 1. Interdisciplinary research. Moscow, Moscow State University, 1996 (in Russian)
- [35] N.N.Bogolyubov and D.V.Shirkov, Introduction to the theory of quantized fields, Moscow, "Nauka", 1976 (in Russian).