



Robust Fuzzy Control for 2-DOF Manipulator System

Ayman A. Aly^{1,2}, Aloqla A.¹

¹Mechanical Engineering Dept., College of Engineering, Taif University, Taif, Saudi Arabia

²Mechanical Engineering Dept., Faculty of Engineering, Assiut University, Assiut, Egypt

Email address:

draymanelnaggar@yahoo.com (A. A. Aly)

To cite this article:

Ayman A. Aly, Aloqla A. Robust Fuzzy Control for 2-DOF Manipulator System. *American Journal of Artificial Intelligence*.

Vol. 1, No. 1, 2017, pp. 56-61. doi: 10.11648/j.ajai.20170101.17

Received: April 26, 2017; **Accepted:** July 25, 2017; **Published:** November 28, 2017

Abstract: Robot manipulators have become increasingly important in the field of automation. So modelling and control of robots in automation will be very important. This paper presents a study of robust control approach employing fuzzy logic control technique for two degree of freedom (2-DOF) manipulator robot. A learning control system is designed so that its “learning mechanism” has the ability to improve the performance of the closed-loop system by generating command inputs to the plant and utilizing feedback information from the plant. It is well known that robotic manipulators are highly nonlinear coupling dynamic systems. A fuzzy logic rule base is designed, using the knowledge obtained from the operator. Simulation is performed to demonstrate the effectiveness of control strategy. Furthermore, the parameters of the controllers were optimized using MATLAB and simulations' result reveals that control scheme is working satisfactorily.

Keywords: Fuzzy Control, Dynamic Model, Robotic, Two DOF Manipulator

1. Introduction

In recent years, control engineers have become increasingly interested in the robot tracking problem. As a result many controllers have been developed which compensate for uncertainty in the nonlinear second-order dynamics commonly used to represent rigid-link robots. Most of the more rigorously developed nonlinear controllers for rigid-link robots fall into two categories, indirect adaptive control and robust nonlinear control. The interested reader is referred to Abdallah et al., [1] and K. A. Khalil et al., [2] for review papers in these two areas. Dynamics of robot manipulators are highly nonlinear and may contain uncertain elements such as friction. Many efforts have been made in developing control schemes to achieve the precise tracking control of robot manipulators [3-5].

A robust fuzzy control design has been developed for a class of nonlinear systems, and the fuzzy control is robustly and globally stabilising. The design assumes a general structure and needs no supervisory control. In this approach, a robust sub-control is designed first and fuzzified for each rule to guarantee closed-loop stability in each fuzzy set. Individual robust controls are then blended into the overall fuzzy controller, [6-7].

This paper is organized as follows: The next section

describes the system dynamics to be controlled. In the third section, robust control system is briefly introduced. The third section describes the control strategy utilizing the proposed approach. Simulation results are presented in the fourth section. The concluding remarks on the system performance are given in the last section.

2. Manipulator Dynamics

The mechanism consists of two intersecting axes at the shoulder and elbow links with revolute joints. The forward kinematics for open chain manipulator is computed by calculating the individual motions for each joint.

There are many methods for generating the dynamics of a mechanical system. All methods generate equivalent sets of equations, but different forms of the equations may be better suited for computation or analysis. A Lagrangian analysis for our derivation will be used, which relies on the energy properties of mechanical systems to compute the equation of motion. The resulting equations can be computed in closed form, allowing detailed analysis of the properties of the system. For each link the frame L_i at the centre of mass and aligned with principle inertia axes of the link.

$$g_{sl_1}(0) = \begin{bmatrix} I & \begin{pmatrix} 0 \\ 0 \\ r_o \end{pmatrix} \\ 0 & 1 \end{bmatrix} \text{ and } g_{sl_2}(0) = \begin{bmatrix} I & \begin{pmatrix} 0 \\ r_1 \\ l_o \end{pmatrix} \\ 0 & 1 \end{bmatrix} \quad (1)$$

Using the Lagrangian formulation, the equations of motion of a two degrees-of-freedom rigid manipulator may be expressed by:

$$T_i(\theta, \dot{\theta}) = \frac{1}{2} (V_{sli}^b)^T M_i V_{sli}^b = \frac{1}{2} \dot{\theta}^T J_i^T(\theta) M_i J_i(\theta) \dot{\theta}, \quad (2)$$

where M_i is the generalized inertia matrix for the i^{th} link. Now the total kinetic energy can be written as

$$T(\theta, \dot{\theta}) = \sum_{i=1}^n T_i(\theta, \dot{\theta}) = \frac{1}{2} \dot{\theta}^T M(\theta) \dot{\theta} \quad (3)$$

The matrix $M(\theta) \in R^{n \times n}$ is the manipulator inertia matrix. In terms of link Jacobians, J_i , the manipulator inertia matrix is defined as

$$M(\theta) = \sum_{i=1}^n J_i^T(\theta) M_i J_i(\theta) \quad (4)$$

With this choice of link frames, the link inertia matrices have the general form

$$M_i = \begin{bmatrix} m_i & 0 & 0 & 0 & 0 & 0 \\ 0 & m_2 & 0 & 0 & 0 & 0 \\ 0 & 0 & m_2 & 0 & 0 & 0 \\ 0 & 0 & 0 & I_{xi} & 0 & 0 \\ 0 & 0 & 0 & 0 & I_{yi} & 0 \\ 0 & 0 & 0 & 0 & 0 & I_{zi} \end{bmatrix}$$

where m_i is the mass of the object and I_{xi}, I_{yi} , and I_{zi} are the moments of inertia about the x -, y -, and z - axes of the i^{th} link frame.

Computation the body Jacobians for each link frame.

$$J_1 = \begin{bmatrix} 0 & 0 \\ 0 & 0 \\ 0 & 0 \\ 0 & 0 \\ 0 & 0 \\ 1 & 0 \end{bmatrix} \text{ and } J_2 = \begin{bmatrix} -r_1 C \varphi & 0 \\ 0 & 0 \\ 0 & -r_1 \\ 0 & -1 \\ -S \varphi & 0 \\ C \varphi & 0 \end{bmatrix} \quad (5)$$

The inertia matrix for the system is given by

$$M(\theta) = \begin{bmatrix} M_{11} & M_{12} \\ M_{21} & M_{22} \end{bmatrix} = J_1^T M_1 J_1 + J_2^T M_2 J_2 \quad (6)$$

where $M_{11} = I_{y2} S^2 \varphi + I_{z1} + I_{z2} C^2 \varphi + m_2 r_1^2 C^2 \varphi$, $M_{12} = 0$,

$$M_{21} = 0, \quad M_{22} = I_{x2} + m_2 r_1^2$$

To complete the derivation of the Lagrangian, the potential energy of the manipulator must be calculated. Let $h_i(\theta)$ be the height of the centre of mass of the i^{th} link (height is the component of the position of the centre mass opposite the direction of gravity). The potential energy for the i^{th} link is

$$V(\theta) = \sum_{i=1}^n V_i(\theta) = \sum_{i=1}^n m_i g h_i(\theta) \quad (7)$$

where m_i is the mass of the i^{th} link and g is the gravitational constant.

Combining this with the kinetic energy, then

$$L(\theta, \dot{\theta}) = \frac{1}{2} \dot{\theta}^T M(\theta) \dot{\theta} - V(\theta) \quad (8)$$

Substitute in Lagrange's equations,

$$\frac{d}{dt} \frac{\partial L}{\partial \dot{\theta}_i} - \frac{\partial L}{\partial \theta_i} = \tau_i \quad (9)$$

where τ_i represent the actuator torque. Then it can arrive to

$$M(\theta) \ddot{\theta} + C(\theta, \dot{\theta}) \dot{\theta} + N(\theta, \dot{\theta}) = \tau \quad (10)$$

where τ is the vector of actuator torques and $N(\theta, \dot{\theta})$ includes gravity terms and others forces which act at the joints. This is a second-order vector differential equation for the motion of the manipulator as a function of the applied joint torques. The matrices M and C , which summarize the inertial properties of the manipulator, have some important properties.

The Coriolis and centrifugal forces are computed directly from the inertia matrix via the formula

$$C_{ij}(\theta, \dot{\theta}) = \sum_{k=1}^n \Gamma_{ijk} \dot{\theta}_k = \frac{1}{2} \sum_{k=1}^n \left(\frac{\partial M_{ij}}{\partial \theta_k} + \frac{\partial M_{ik}}{\partial \theta_j} - \frac{\partial M_{kj}}{\partial \theta_i} \right) \dot{\theta}_k \quad (11)$$

A very messy calculation shows that the nonzero values of Γ_{ijk} are given

$$\begin{aligned} \Gamma_{11} &= C \varphi S \varphi (I_{y2} - I_{z2} - m_2 r_1^2), \\ \Gamma_{12} &= C \varphi S \varphi (I_{y2} - I_{z2} - m_2 r_1^2), \\ \Gamma_{21} &= C \varphi S \varphi (I_{z2} - I_{y2} + m_2 r_1^2) \end{aligned}$$

Finally, the effect of gravitational forces on the manipulator are written as $N(\theta, \dot{\theta}) = \frac{\partial V}{\partial \theta}$,

where $V: R^n \rightarrow R$ is the potential energy of the manipulator.

$$V(\theta) = m_1 g h_1(\theta) + m_2 g h_2(\theta) \quad (12)$$

where h_i is the height of the centre of mass for the i^{th} link. These can be found using the forward kinematics map

$$g_{s_i}(\theta) = e^{\hat{\zeta}_1 \theta_1} \dots e^{\hat{\zeta}_i \theta_i} g_{s_i}(\theta) \quad (13)$$

which gives $h_1(\alpha) = r_o$, $h_2(\varphi) = l_o - r_1 S\varphi$

Substituting these expressions into the potential energy and taking the derivative gives

$$N(\theta, \theta) = \frac{\partial V}{\partial \theta} = \begin{bmatrix} 0 \\ -m_2 g r_1 C\varphi \end{bmatrix} \quad (14)$$

3. Fuzzy Model Reference Learning Control (FMRLC) Design

The fuzzy controller by itself has little knowledge about how to control the manipulator. As the algorithm executes, the output membership functions are rearranged by the learning mechanism, filling up the rule base. For instance, once a slew is commanded, the learning mechanism described below will move the centres of the output membership functions of the activated rules away from zero and begin to synthesize the fuzzy controller. In this case, it

developed an FMRLC for automatically synthesizing and tuning a fuzzy controller for the system. The FMRLC structure shown in Figure 1 was used, which tunes the coupled direct fuzzy controller. Next, Each component of the FMRLC for the two-link system will be described, [9-10].

The universe of discourse for the position error $e1$ to the shoulder link controller was chosen to be $[-100, +100]$ degrees, and the universe of discourse for the endpoint acceleration $a1$ is $[-10, +10]$ g. For the elbow link controller, the universe of discourse for the position error $e2$ is $[-80, +80]$ degrees, and the universe of discourse for the endpoint acceleration $a2$ is $[-8, +8]$ g. The output universe of discourse for $v1$ and $v2$ by getting $g_{v1} = 0.125$ and $g_{v2} = 1.0$ was chosen.

The desired performance is achieved if the learning mechanism forces $y_{e1}(kT) \cong 0$, $y_{e2}(kT) \cong 0$, for all $k \geq 0$. It is important to make a proper choice for a reference model so that the desired response does not dictate unreasonable performance requirements for the plant to be controlled. through simulation, it was determined that $\frac{3}{s+3}$ is a good

choice for the reference models for both the shoulder and the elbow links.

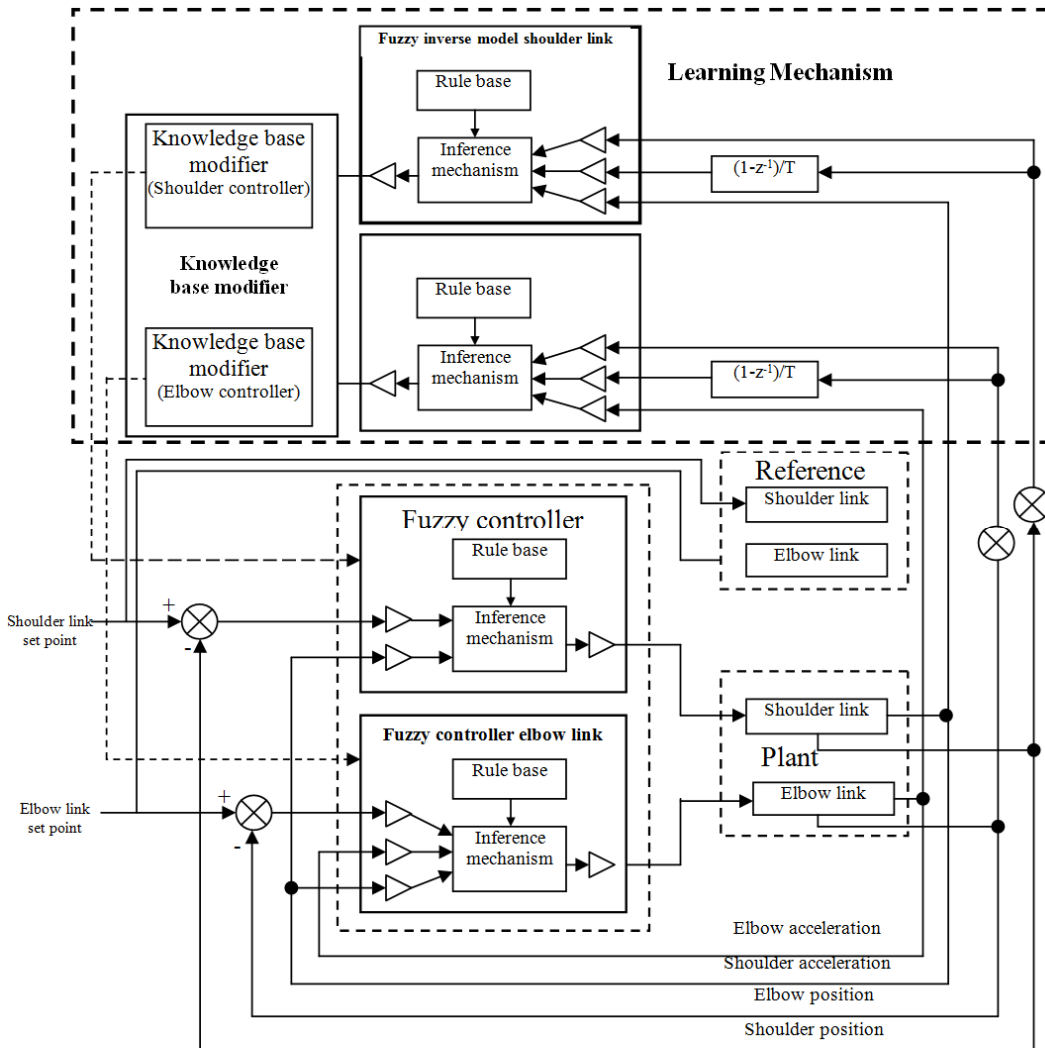

Figure 1. FLMRC for the two link robot.

3.1. The Fuzzy Inverse Models

There are several steps involved in specifying the fuzzy inverse models and these are outlined next. Choice of Inputs: For our system there are two inverse models, each with three inputs $ye_j(t)$, $yc_j(t)$, and $a_j(t)$ ($j=1$ corresponding to shoulder link and $j=2$ corresponding to elbow link). Several issues dictated the choice of these inputs: (1) it is easy to specify reference models for the shoulder and elbow link position trajectories (as discussed above) and hence the position error signal is readily available; (2) it is found via simulation that the rates of change of position errors, $yc_j(t)$, $j=1, 2$, and acceleration signals $a_j(t)$, $j=1, 2$, were very useful in deciding how to adjust the fuzzy controller; and (3) to minimize the number of inputs to the fuzzy inverse models to ensure that it could implement the FMLRC with a short enough sampling interval (in our case, 15 milliseconds). The direct use of the acceleration signals $a_j(t)$, $j=1, 2$, for the inverse models actually corresponds to choosing reference models for the acceleration signals that say "no matter what slew is commanded, the desired accelerations of the links should be zero" (why?). While it is clear that the links cannot move without accelerating, with this choice the FMLC will attempt to accelerate the links as little as possible to achieve the command slews, thereby minimizing the amount of energy injected into the modes of vibration. Next, rule base design for the fuzzy inverse models were discussed.

3.2. Choice of Rule Base

For the rule bases of the fuzzy inverse models, rules similar to those described in [10] was used, for both the shoulder and elbow links except that the cubical block of zeros is eliminated by making the pattern of consequents uniform. These rules have premises that quantify the position error, the rate of change of the position error, and the amount of acceleration in the link. The consequents of the rules represent the amount of change that should be made to the direct fuzzy controller by the knowledgebase modifier. For example, fuzzy inverse model rules capture knowledge such as (1) if the position error is large and the acceleration is moderate, but the link is moving in the correct direction to reduce this error, then a smaller change (or no change) is made to the direct fuzzy controller than if the link were moving to increase the position error; and (2) if the position error is small but there is a large change in position error and a large acceleration, then the fuzzy controller must be adjusted to avoid overshoot. Similar interpretations can be made for the remaining portions of the rule bases used for both the shoulder and elbow link fuzzy inverse models.

3.3. Choice of Membership Functions

The membership functions for both the shoulder and elbow link fuzzy inverse models are similar to those used for the elbow link controller expect that the membership functions on the output universe of discourse are uniformly distributed and there are different widths for the universes of discourse,

as it was explained next (these widths define the gains g_{ye_j} , g_{yc_j} , g_{a_j} , and g_{p_j} for $j=1, 2$). The universe of discourse for ye_j to be $[-80, +80]$ degrees for the shoulder link was chosen and $[-50, +50]$ for the elbow link. A larger universe of discourse for the shoulder link inverse model was chosen than for the elbow link inverse model because it need to keep the change of speed of the shoulder link and $[-150, +150]$ for the elbow link. A larger universe of discourse for the shoulder link inverse model than for the elbow link inverse model was chosen because it need to keep the change of speed of the shoulder link gradual so as not to induce oscillations in the elbow link (the elbow link is mounted on the shoulder link and is affected by the oscillations in the shoulder link). The universe of discourse for yc_1 is chosen to be $[-400, +400]$ degrees/second for the shoulder link and $[-150, +150]$ degrees/second for yc_2 of the elbow link. These universes of discourse were picked after experimental determination of the angular velocities of the links. The output universe of discourse for the fuzzy inverse model outputs (p_1 and p_2) is chosen to be relatively small to keep the size of the changes to the fuzzy controller small, which helps ensure smooth movements of the robot links. In particular, The output universe of discourse to be $[-0.125, +0.125]$ for the shoulder link inverse model was chosen, and $[-0.05, +0.05]$ for the elbow link inverse model. Choosing the output universe of discourse for the inverse models to be $[-1, +1]$ causes the learning mechanism to continually make the changes in the rule base of the controller so that the actual output is exactly equal to the reference model output, making the actual plant follow the reference model closely. This will cause significant amounts of speed variations in the motors as they try to track the reference models exactly resulting in chattering along a reference model path, The choice of a smaller width for the universe of discourse keeps the actual output below the output of the reference model until it reaches the set point. This increases the settling time slightly but the response is much less oscillatory. This completes the definition of two fuzzy inverse models in Figure 1.

3.4. The Knowledge Base Modifier

Given the information (from the inverse models) about the necessary changes in the input needed to make $ye_1 \cong 0$ and $ye_2 \cong 0$, the knowledge base modifier changes the knowledge base of the fuzzy controller so that the previously applied control action will be modified by the amount specified by the inverse model outputs p_i , $i=1, 2$. To modify the knowledge base, the knowledge base modifier shifts the centres of the output membership functions (initialized at zero) of the rules that were "on" during the previous control action by the amount $p_1(t)$ for the shoulder controller and $p_2(t)$ for the elbow controller.

Note that to achieve good performance, it was found via simulation that certain enhancements to the FMRLC knowledge base modification procedure were needed.

4. Simulation of 2-DOF Model with Direct FMRLC System

The total number of rules used by the FMRLC is 121 for the shoulder controller, plus 343 for the base axis controller, plus 343 for the shoulder fuzzy inverse model, plus 343 for the base axis fuzzy inverse model, for a total of 1150 rules. Even with this number of rules, The sampling time of $T=1$ milliseconds was used for the direct fuzzy controller.

Simulation results obtained from the use of the FMRLC are shown in Figures 2- (a & b) and 3- (a & b) for a slew of 1 for each link. The rise time for the response is about 0.3 sec. and 0.25 sec, the settling time is approximately 0.2 sec. and 0.14, the delay time is 0.005 sec. and 0.1 with zero steady state errors for the two axes.

Different payloads change the model frequencies in the link/payload combination (e.g., heavier loads tend to reduce the frequencies of the modes of oscillation) and the shapes of the error and acceleration signals $e_1(t)$, $e_2(t)$, and $a_1(t)$ (e.g., behaviour loads tend to slow the plant responses). Hence,

Changing the payload simply results in the FMRLC developing, remembering, and applying different responses depending on the type of the payload variation that occurred. Essentially, the FMRLC uses data from the closed-loop system that is generated during the simulation operation of the plant. This enables it to achieve better performance than the direct fuzzy controller described above. The cross ponding controller signals is cleared in lower part of each figure.

Figure 4-a shows the time responses of step disturbance reference input, the recovering had happened after 0.2 sec. for the base axis with zero steady state error. In Figure 5-a after 0.3 sec. for the shoulder axis with zero steady state error. The cross ponding controller signal is shown in Figures 4-b and 5-b.

The difference which had happened between the reference input and the axes response because of the way the learning mechanism modified the rule base of the controller to keep the response below that of the reference model.

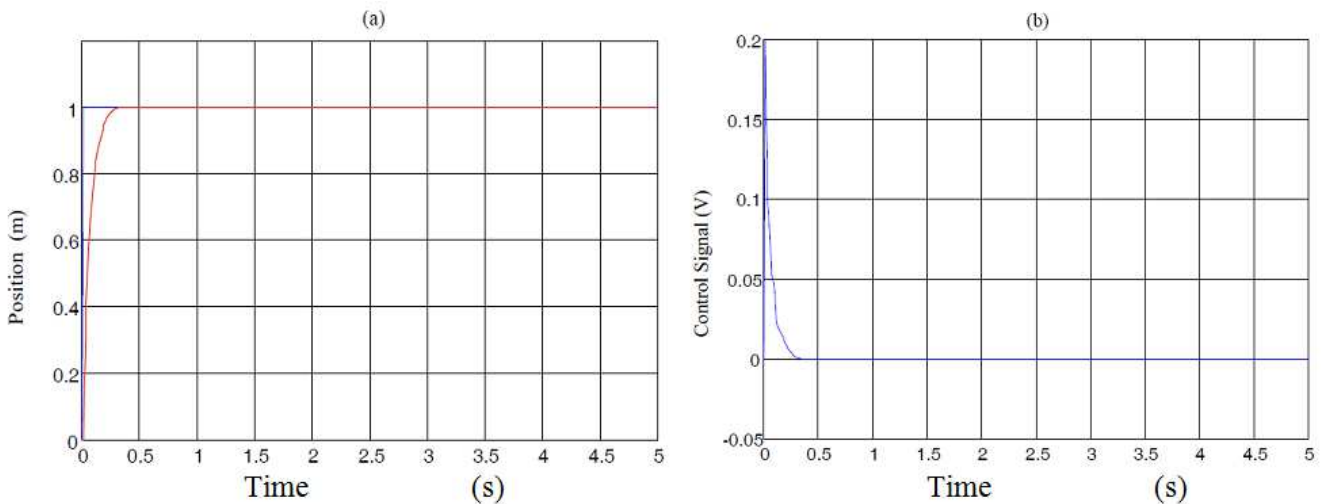

Figure 2. System step response based on fuzzy controller (Base Axis).

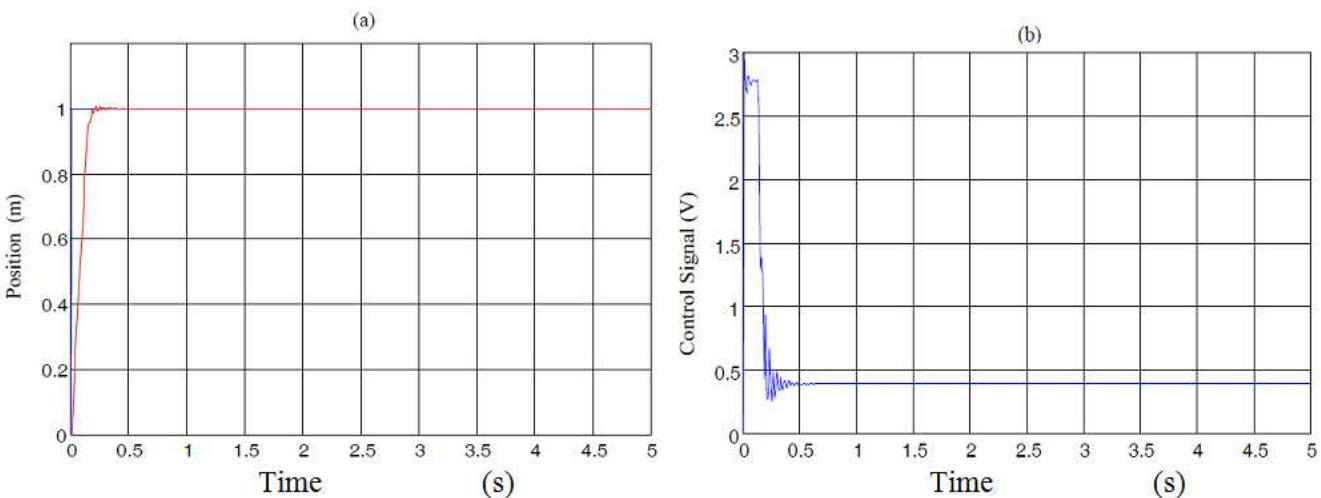

Figure 3. System step response based on fuzzy controller (Shoulder Axis).

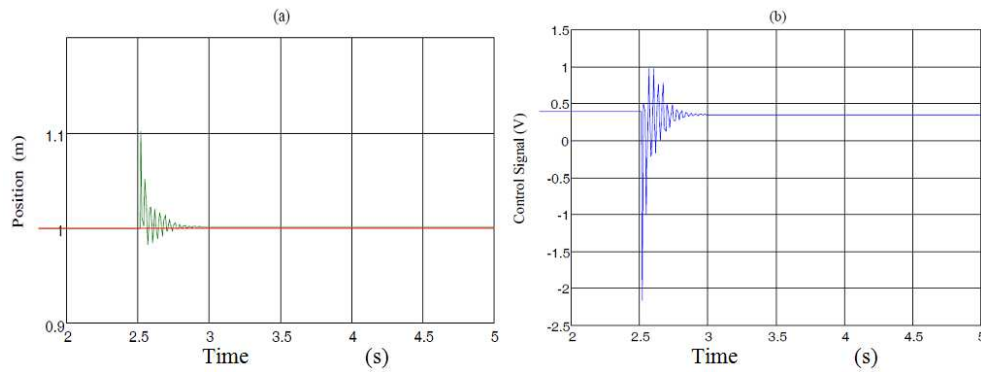

Figure 4. System motion curve response based on fuzzy controller (Shoulder Axis).

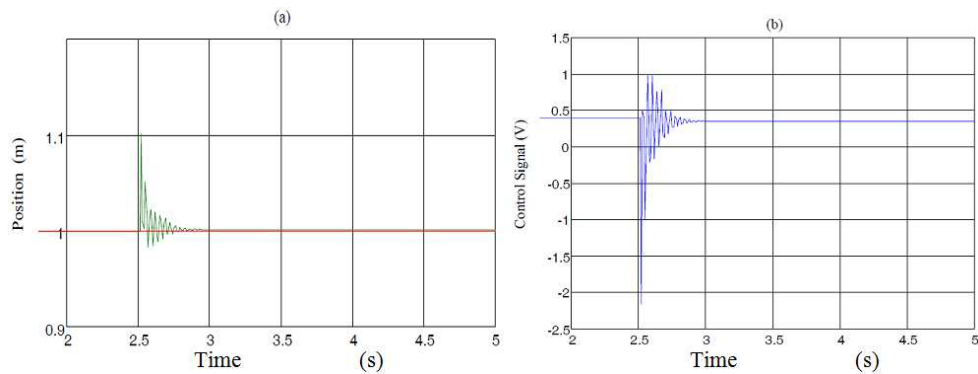

Figure 5. System motion curve response based on fuzzy controller (Shoulder Axis).

5. Conclusion

In this paper, a design approach that can be used to design robot tracking controller was developed which compensate for nonlinear dynamics in robot model. One of the most important challenges in the field of robotics is robot manipulators control with acceptable performance, because these systems are multi-input multi-output (MIMO), nonlinear and uncertainty. The control problem of a nonlinear system such as the two DOF system is studied in this paper. A fuzzy controller has been implemented.

Although fuzzy logic control has a model-free feature, it still needs time-consuming work for the rules bank and fuzzy parameters adjustment. This approach has a learning ability for responding to the time-varying characteristic of the system. Its control rules bank can be established and modified continuously by online learning with zero initial fuzzy rules. FMRLC designed in this case is found to be adoptive and robust with strong learning ability.

References

- [1] ABDALLAH, C., D Awso N, D. M., Do RATO, P., and JAMrsmm, M., 1991, Survey of the robust control of robots. IEEE Control Systems Magazine, 11, (2), 24-30.
- [2] Khalil A. Khalil, Ayman A. Aly, and A. Abo-Ismael, "Adaptive Based Block Fuzzy Controller of Flexible Robot Arm", IASTED International Conference on Intelligent Systems and Control, Orlando, USA, November 16 - 18, 2008.
- [3] Ayman A. Aly, Farhan A. Salem, "Design of Intelligent Position Control for Single Axis Robot Arm", International Journal of Scientific & Engineering Research, IJSER, Volume 5, Issue 6, pp 790-795, 2014.
- [4] BARNETT, S., 1984, Matrices in Control Theory (Malabar, Fla.: Robert E. Krieger).
- [5] CORLESS, M., 1989, Tracking controllers for uncertain systems: application to a mantic R3 robot. Journal of Dynamic Systems, Measurement and Control, 111, 609-618.
- [6] CORLESS, M. J., and LEITMANN, G., 1981, Continuous state feedback guaranteeing uniform ultimate boundedness for uncertain dynamic systems. IEEE Transactions on Automatic Control, 26, 1139-1143.
- [7] Ayman A. Aly and Aly S. Abo El-Lail, "Self Tuning PI Fuzzy Position Control of A Hydraulic Manipulator" Journal of Engineering Science, JES, Vol. 33, No. 1, pp 199-209, January 2005.
- [8] Ayman A. Aly, "Motion Control Of A Mechatronics System Using Fuzzy Model Reference Learning Technique", Multidisciplinary International Peer Reviewed Journal, SAUSSUREA, Vol. 5 (6): PP. 96-102, 2015
- [9] J. J. E. Slotine and W. Li, Applied nonlinear control vol. 461: Prentice hall Englewood Cliffs, NJ, 1991.
- [10] Ayman A. Aly, "Motion Control of A Mechatronics System Using Fuzzy Model Reference Learning Technique", Multidisciplinary International Peer Reviewed Journal, SAUSSUREA, Vol. 5 (6): PP. 96-102, 2015.