Performance Analysis of Cellular Radio System Using Artificial Neural Networks

Kriti Priya Gupta^{1,*}, Madhu Jain²

¹Symbiosis Centre for Management Studies, NOIDA Faculty of Management, Symbiosis International University, Pune, India

²Department of Mathematics, Indian Institute of Technology (IIT), Roorkee, India

Email address:

kriti.gupta@scmsnoida.ac.in (K. P. Gupta), madhujain@sancharnet.in (M. Jain)

*Corresponding author

To cite this article:

Kriti Priya Gupta, Madhu Jain. Performance Analysis of Cellular Radio System Using Artificial Neural Networks. *American Journal of Neural Networks and Applications*. Vol. 3, No. 1, 2017, pp. 5-13. doi: 10.11648/j.ajjna.20170301.12

Received: December 26, 2016; **Accepted:** January 6, 2017; **Published:** March 17, 2017

Abstract: In this paper, we exploit one of the fastest growing techniques of Soft Computing, i.e. Artificial Neural Networks (ANNs) for obtaining various performance measures of a cellular radio system. A prioritized channel scheme with subrating is considered in which a fixed number of channels are reserved for handoff calls and in case of heavy traffic, these reserved channels are subrated into two channels of equal frequency to deal with more handoff calls. Two models dealing with infinite and finite number of subscribers are considered and the blocking probabilities of new and handoff calls are computed analytically as well as by using ANNs. A feedforward two-layer ANN is considered for obtaining the blocking probabilities. The backpropagation algorithm is used for training the ANN. The analytical and ANN results are compared by taking the numerical illustrations.

Keywords: Artificial Neural Networks, Cellular Radio System, Handoff, Reserved Channels, Subrating, Backpropagation

1. Introduction

Among the various paradigmatic changes in science and technology that have taken place in this century, one such change concerns the concept of Soft Computing (SC). Soft computing provides flexible information processing capabilities for handling real life ambiguous situations. Hard computing has the characteristics of precision and categoricity while the soft computing has the properties of approximation and dispositionality. Soft computing exploits the tolerance for imprecision and uncertainty to achieve tractability, lower cost, high Machine Intelligence Quotient (MIQ) and economy of communication.

One of the most powerful techniques of soft computing is Artificial Neural Networks, which aims to perceive and comprehend the significance of the data with which they are trained. ANN approach is frequently employed to analyze a variety of problems and is best distinguished from other SC techniques in that it is non-rule-based and can additionally be made stochastic so that the same action does not necessarily take place each time for the same input. A stochastic

behavior allows a neural network to explore its environment more fully and potentially to arrive at a better solution than the conventional methods. ANN is a powerful data-modeling tool that is able to capture and represent complex input/output relationships. The properties of ANN like learning and adaptation, classification, function approximation etc. have made them of extreme use in solving various mathematical problems. Neural networks have been successfully applied to broad spectrum of data-intensive applications, such as Signal Processing [1], Chip Designing [2], optimization problems [3] and in many engineering problems [4]. ANNs are also used for solving problems that are too complex for conventional technologies e.g., problems that do not have an algorithmic solution or for which an algorithmic solution is too complex to be found.

There are multitudes of different types of ANNs. Some of the more popular include the Multilayer Perceptrons (MLPs), which are generally trained with the backpropagation algorithm [5]. This type of neural network consists of multiple layers and is known as a supervised network because it requires a desired output in order to learn. The goal of this type of network is to create a model that correctly

maps the input to the output using historical data so that the model can then be used to produce the output when the desired output is unknown. A three-layer feedforward ANN with sigmoidal activation functions in the hidden layer and trained using the backpropagation algorithm, is able to approximate an arbitrary nonlinear function [6].

ANNs have been applied to the problem of traffic prediction, adaptive control of nonlinear traffic etc. [7, 8, 9, 10, 11]. Researchers have used ANNs for bandwidth allocation [12], admission control [13, 14] and for computing the optimal number of channels to be allocated to various users in GPRS [15]. Several researchers have used ANNs and other soft computing techniques for studying channel assignment problems in cellular networks [16, 17, 18, 19]. Some researchers have also used ANN for location detection and prediction in cellular networks [21, 22].

In this paper, we consider a cellular radio system with a prioritized scheme in which some channels are fixed exclusively for the handoff calls. Also the reserved channels are subrated into two channels of equal bandwidth for serving more handoff calls in case of heavy traffic. A feedforward ANN with three layers is employed to compute the blocking probabilities of new and handoff calls. The backpropagation algorithm is used for training the network. The rest of the paper is organized as follows: In section 2, the basic architecture of an ANN is described along with the backpropagation algorithm. The analytical model for the cellular radio system is discussed in section 3. In section 4, the ANN approach for computing the blocking probabilities of the cellular system, is discussed. The results obtained from the analytical method and ANN are compared in section 5 by taking the numerical illustrations. Finally, the conclusion is drawn in section 6.

2. Architecture of ANN

ANNs are closely modeled on biological processes for information processing, including specifically the nervous system, and the *neuron*. A mathematical model of the *neuron* is depicted in Figure 1. It shows n inputs with associated *weights* v_j ($j=1,2,\dots,n$) and the *bias* v_0 . The output y can be expressed as

$$y = \sigma\left(\sum_{j=1}^n v_j x_j + v_0\right) \tag{1}$$

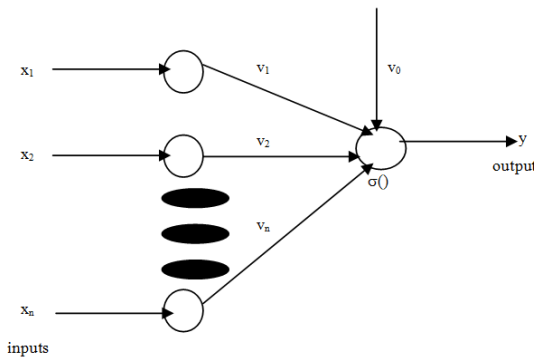

Figure 1. Mathematical Model of a Neuron.

where $\sigma(\cdot)$ is a differentiable function known as the *activation function* which is selected differently in different applications.

Figure 2 exemplifies a graphical representation of a three-layer ANN. The first layer is known as the *input* layer with n number of inputs and the second layer is known as the *hidden* layer, with L number of hidden-layer neurons. The third layer is known as the *output* layer with m number of neurons. ANN with multiple layers are known as MLPs. The computing power of MLPs is significantly enhanced over the two-layer ANN which consists of only input and output layers. The output of the three-layer ANN is given by

$$y_i = \sigma_2\left(\sum_{l=1}^L w_{il}\sigma_1\left(\sum_{j=1}^n v_{lj}x_j + v_{l0}\right) + w_{i0}\right), \quad i = 1, 2, \dots, m \tag{2}$$

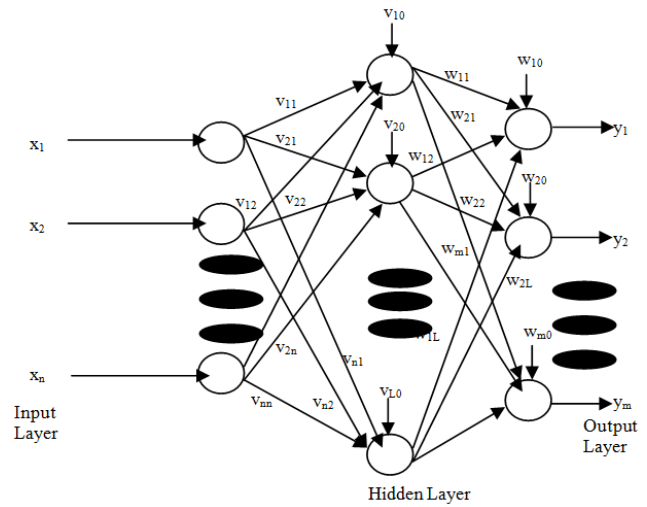

Figure 2. Three-Layer Artificial Neural Network.

where v_{ij} is the weight for the j^{th} input to the i^{th} neuron of the hidden layer and w_{il} is the weight from the l^{th} neuron of the hidden layer to the i^{th} neuron of the output layer. $\sigma_1(\cdot)$ is the activation function for the hidden layer and $\sigma_2(\cdot)$ is for the output layer.

The MLP and many other ANNs learn using an algorithm called *backpropagation*. With backpropagation, the input data is repeatedly presented to the neural network. With each presentation, the output of the ANN is compared to the desired output and an *error* is computed. This *error* is then fed back (backpropagated) to the neural network and used to adjust the weights such that the error decreases with each iteration and the ANN gets closer and closer to producing the desired output. This process is known as *training*. The backpropagation algorithm for a two layer ANN is described below:

Backpropagation Algorithm

Inputs: Number of inputs, n ; Input pattern, X ; Number of neurons in the hidden layer, L ; Number of neurons in the output layer, m ; Desired output pattern, Y ; Activation functions σ_1 and σ_2 ; Learning rate, η ; Number of epochs, NE ; Error goal to be reached, ϵ .

Process:

- Step 1: Initialize $E = 1$ and $e = 0$;
- Step 2: Present the input pattern X to the ANN;
- Step 3: Repeat Steps 4 to 8 until $E < \epsilon$ or $e > NE$
- Step 4: Initialize weights v_{ij} and w_{il} randomly;
- Step 5: Compute the outputs of the two layers as

$$z_l = \sigma_1 \left(\sum_{j=0}^n v_{lj} X_j \right), \quad l = 1, 2, \dots, L \text{ and } X_0 = 1;$$

$$y_i = \sigma_2 \left(\sum_{l=0}^L w_{il} z_l \right), \quad i = 1, 2, \dots, m \text{ and } z_0 = 1;$$

Step 6: Compute the sum-squared error as

$$E = \frac{1}{2} \sum_{i=1}^m (Y_i - y_i)^2$$

Step 7: Update the weights in layers 2 and 1 respectively according to

$$w_{il} = w_{il} - \eta \frac{\partial E}{\partial w_{il}}; \quad i = 1, 2, \dots, m; l = 1, 2, \dots, L;$$

$$v_{ij} = v_{ij} - \eta \frac{\partial E}{\partial v_{ij}}; \quad l = 1, 2, \dots, L; j = 1, 2, \dots, n;$$

- Step 8: $e = e + 1$;
- Output: Updated weights for the two layers.

3. Analytical Model for Prioritized Scheme in Cellular Radio System

We consider a cellular system with a prioritized channel scheme in which, a fixed number of channels are reserved exclusively for the hand-off calls. In order to deal with heavy traffic conditions, these reserved channels are also subrated i.e. a reserved channel is divided into two channels of equal frequency. Jain and Rakhee [20] studied cellular system with subrating. Two models are considered with finite and infinite subscribers respectively. Both models are discussed later in this section. The arrival rates of all the calls are assumed to be Poisson and the service times are distributed exponentially. The mean call holding times and call residence times also follow exponential distribution.

Following notations are used for mathematical formulation of the analytical model:

M	Number of subscribers
C	Total number of channels in the cellular system
r	Number of channels reserved for handoff calls
$1/\mu$	Mean call-holding time
$1/\eta$	Mean cell residence time of each portable
λ_v	Arrival rates of new calls
λ_η	Arrival rates of handoff calls
λ	Arrival rate of calls; $\lambda = \lambda_v + \lambda_\eta$
P_0	Steady state probability that there is no call in the system
P_i	Steady state probability that there are i calls in the

	system
B_n	Blocking probability of new calls
B_h	Blocking probability of handoff calls

3.1. Model with Infinite Number of Subscribers (ISM)

In this model, the number of subscribers in the system is assumed to be finite. The steady state probabilities are obtained as follows:

$$P_i = \begin{cases} \frac{\lambda^i}{i!(\mu + \eta)^i} P_0 & 0 \leq i \leq c - r \\ \frac{\lambda^{c-r} \lambda_h^{i-(c-r)}}{i!(\mu + \eta)^i} P_0 & c - r + 1 \leq i \leq c + r \end{cases} \quad (3)$$

where P_0 is computed by using normalization condition as

$$P_0 = \left[\sum_{i=0}^{c-r} \frac{\lambda^i}{i!(\mu + \eta)^i} + \sum_{i=c-r+1}^{c+r} \frac{\lambda^{c-r} \lambda_h^{i-(c-r)}}{i!(\mu + \eta)^i} \right]^{-1} \quad (4)$$

3.2. Model with Finite Number of Subscribers (FSM)

In this model, the number of subscribers is taken as finite, i.e. M. The steady state probabilities are given by the following equations:

$$P_i = \begin{cases} \frac{\binom{M}{i} \lambda^i}{(\mu + \eta)^i} P_0 & 0 \leq i \leq c - r \\ \frac{\binom{M}{i} \lambda^{c-r} \lambda_h^{i-(c-r)}}{(\mu + \eta)^i} P_0 & c - r + 1 \leq i \leq c + r \end{cases} \quad (5)$$

$$\text{Where } P_0 = \left[\sum_{i=0}^{c-r} \frac{\binom{M}{i} \lambda^i}{(\mu + \eta)^i} + \sum_{i=c-r+1}^{c+r} \frac{\binom{M}{i} \lambda^{c-r} \lambda_h^{i-(c-r)}}{(\mu + \eta)^i} \right]^{-1} \quad (6)$$

Performance Measures

The blocking probabilities of new and handoff calls for both the models are calculated as

$$B_n = \sum_{i=c-r}^{c+r} P_i \quad (7)$$

and

$$B_h = P_{c+r} \quad (8)$$

4. The ANN Approach for Computing Blocking Probabilities

Now, we describe the ANN model for computing the performance measures of the cellular system discussed in the previous section. We consider a two-layer feedforward ANN with L neurons in the hidden layer and one neuron in the output layer. The activation functions at the hidden layer and output layer are assumed to be 'sigmoid' and 'linear'

respectively. The backpropagation algorithm is employed for training the network. For studying the effect of different parameters on the performance measures of the analytical models, ANNs with different combinations of input and output neurons are used, which are described in figures 3-6. The ANNs described in figures 3a and 3b are used to study the effect of λ_v on B_n and B_h respectively for both models where, λ_v is the input neuron and B_n and B_h respectively are the output neurons. In the ANNs shown in figures 4a and 4b, C is the input neuron and B_n and B_h are the outputs respectively. The ANNs in figures 5a and 5b have two input neurons i.e C and r , and the output neurons are B_n or B_h . For studying the effect of M for FSM, the ANNs used have M as the input neuron and B_n and B_h as the output neuron as demonstrated in figures 6a and 6b.

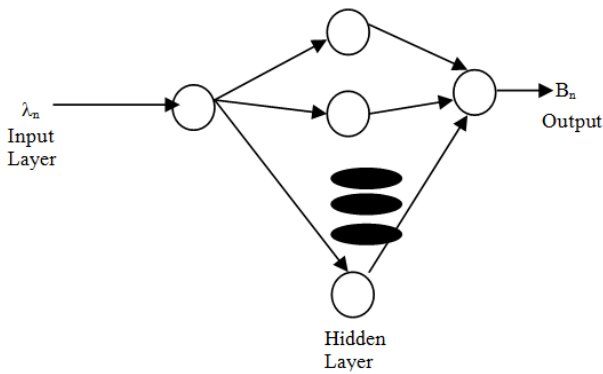

Figure 3a. ANN Model for calculating B_n taking λ_v as input.

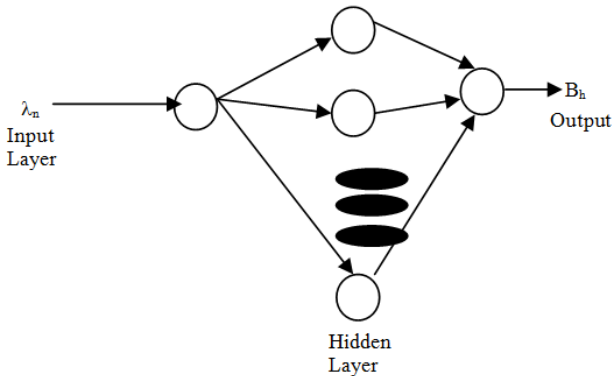

Figure 3b. ANN Model for calculating B_h taking λ_v as input.

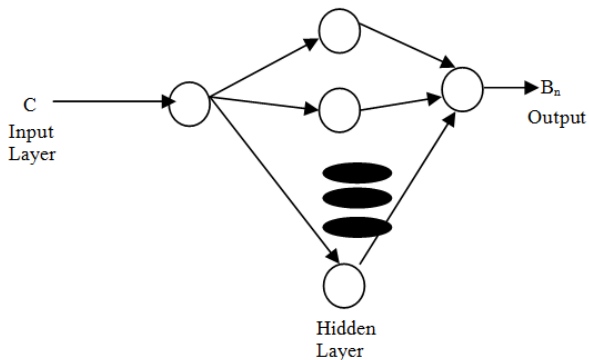

Figure 4a. ANN Model for calculating B_n taking C as input.

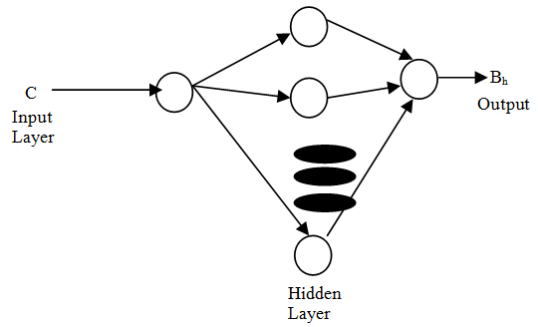

Figure 4b. ANN Model for calculating B_h taking C as input.

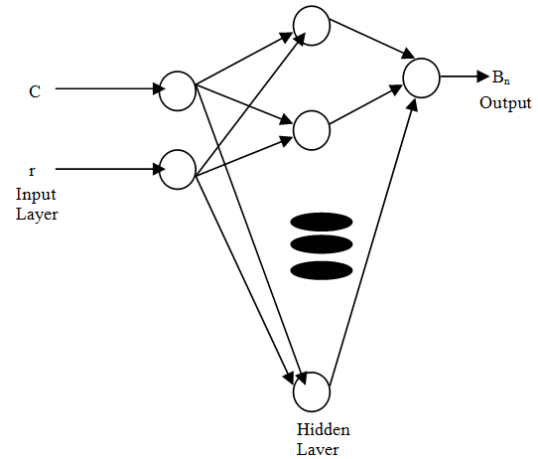

Figure 5a. ANN Model for calculating B_n taking C and r as inputs.

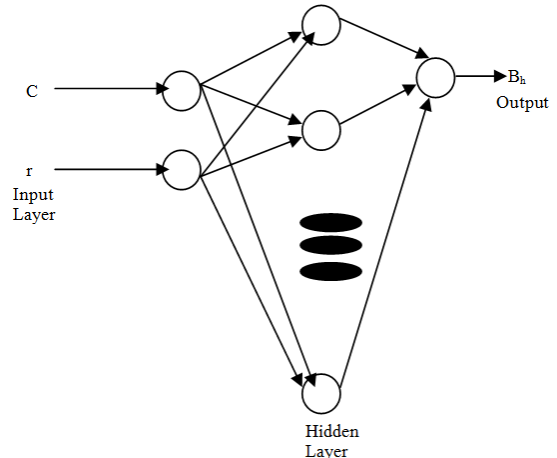

Figure 5b. ANN Model for calculating B_h taking C and r as inputs.

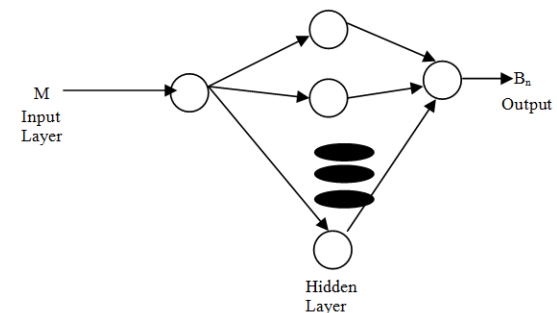

Figure 6a. ANN Model for calculating B_n for FSM taking M as input.

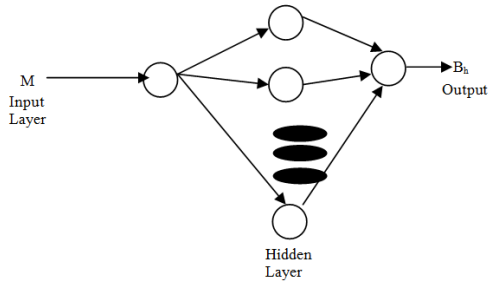

Figure 6b. ANN Model for calculating B_h for FSM taking M as input.

5. Numerical Experiment

In this section, we compare the analytical results obtained

Table 1. ANN Parameters.

Fig. No.	7(a)	8(a)	9(a)	10(a)	11(a)-11(d)	12(a) & 12(b)
No. of Epochs	900	1000	894	800	1000	2000
No. of Epochs after which SSE is calculated	100	100	100	100	200	500
No. of neurons in hidden layer (L)	20	15	25	15	20	15
Error goal	10^{-3}	10^{-2}	10^{-6}	10^{-3}	10^{-5}	10^{-11}

Figures 7a and 8a exhibit the analytical as well as ANN results for B_n and B_h of ISM respectively by varying λ_0 . Similarly, B_n and B_h for FSM by varying λ_0 are shown in figures 9a and 10a. Obviously, both B_n and B_h increase with λ_0 for both the models. The variation of the sum-squared error with the number of epochs for each computation is demonstrated in figures 7b-10b corresponding to the figures 7a-10a. We notice that SSE decreases with the increase in the number of epochs and finally SSE reaches the required error goal. The respective error surface graphs are also shown in the figures 7c-10c. These graphs represent those values of the weights and biases for the ANNs, which give the lowest error. In each of these graphs, we note that the error surface has a global minimum at the center of the plot and the side valleys lead to local minima.

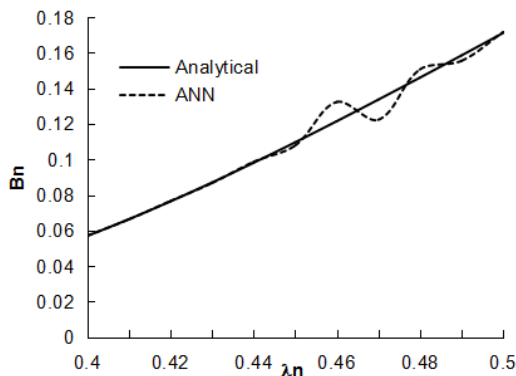

Figure 7a. B_n by varying λ_n for ISM.

Figures 11a – 11d display the ANN results for B_n and B_h for ISM and FSM by varying C and r both. We note that for both models ISM and FSM, B_n decreases with C and increases with r . Also, B_h decreases with r and is almost constant with C . These results are quite comparable with the analytical results.

in section 3 with the ANN results by taking some numerical illustrations. Firstly, we determine the performance measures for the models ISM and FSM by using the analytical results. Then these results are validated by using the ANN models discussed in section 4. For illustration, we assume $C=30$, $r=2$ and the arrival rate of handoff calls to be 20% of that of the new calls, i.e. $\lambda_h=20\%\lambda_0$. For ISM, μ is taken as 0.015 and η is assumed to be 0.006. For FSM, we take $\mu=0.15$, $\eta=0.6$ and $M=46$. For all ANN models, the learning rate (lr) is taken as 0.01. Other ANN parameters for various results are summarized in table 1. For all ANN models, the backpropagation algorithms are run on Pentium IV using MATLAB 5.2.

Figures 12a and 12b depict the effect of M on B_n and B_h respectively for FSM by taking analytical and ANN results as well. We notice the obvious result that both B_n and B_h increase with M as expected.

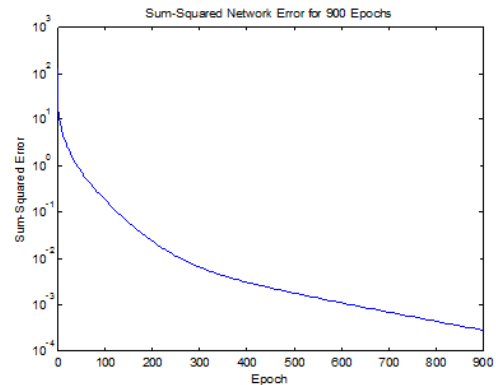

Figure 7b. SSE vs. Epochs for Fig. 7a.

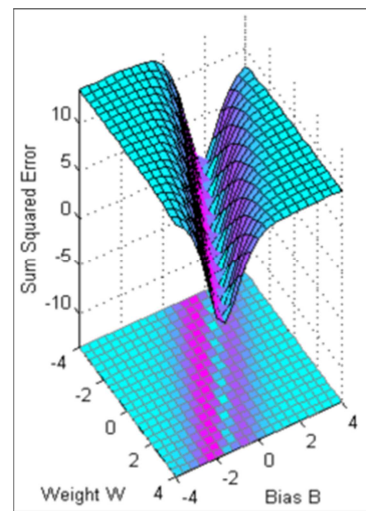

Figure 7c. Error Surface Graph for Fig. 7a.

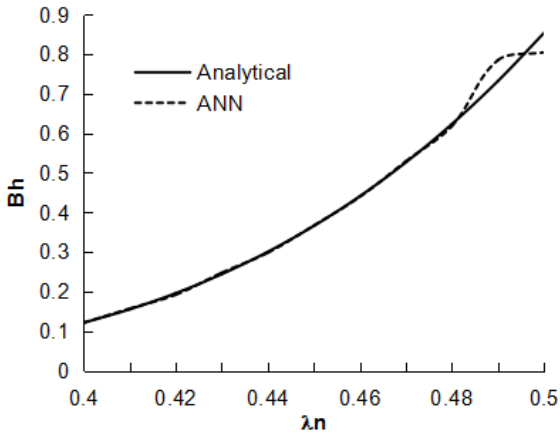

Figure 8a. B_h by varying λn for ISM.

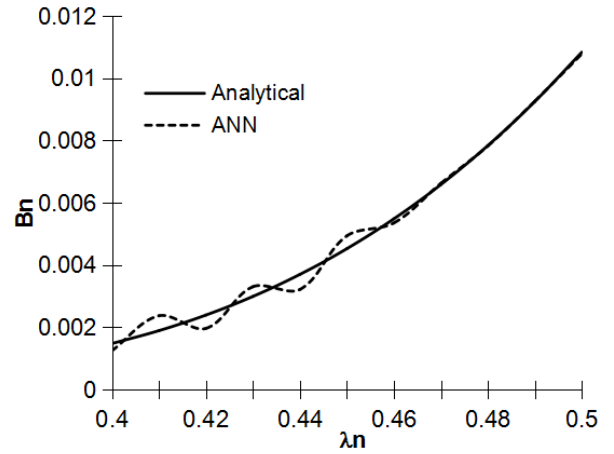

Figure 9a. B_n by varying λn for FSM.

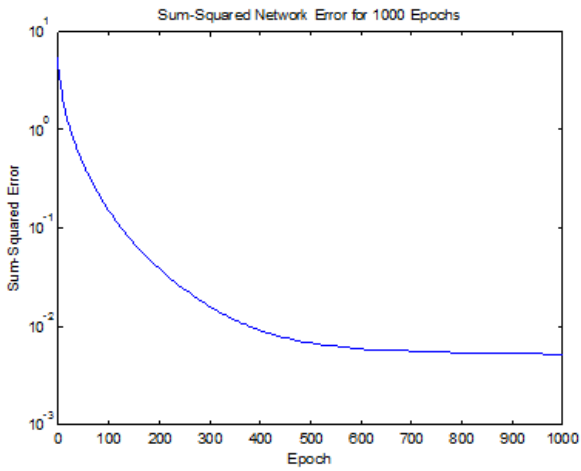

Figure 8b. SSE vs. Epochs for Fig. 8(a).

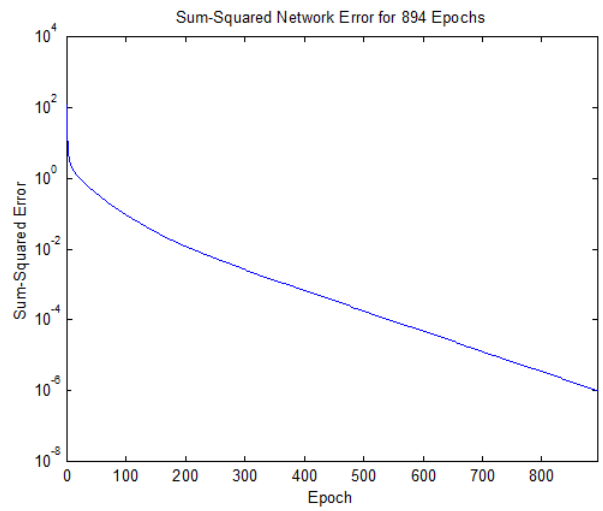

Figure 9b. SSE vs. Epochs for Fig. 9(a).

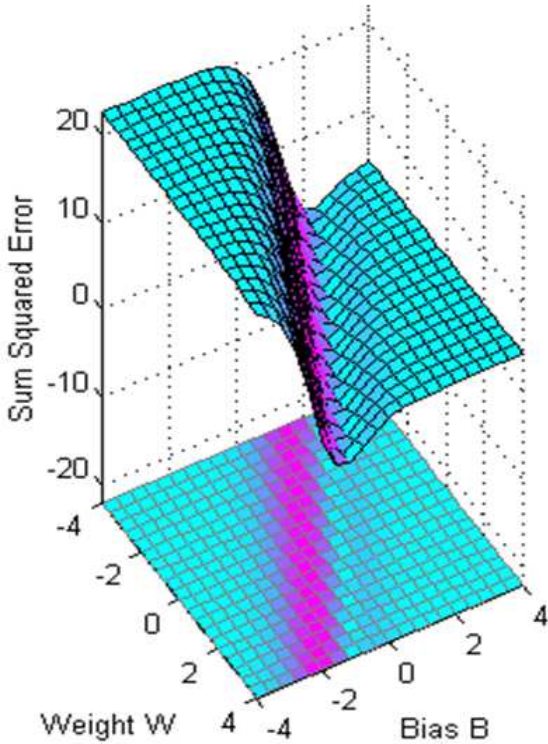

Figure 8c. Error Surface Graph for Fig. 8(a).

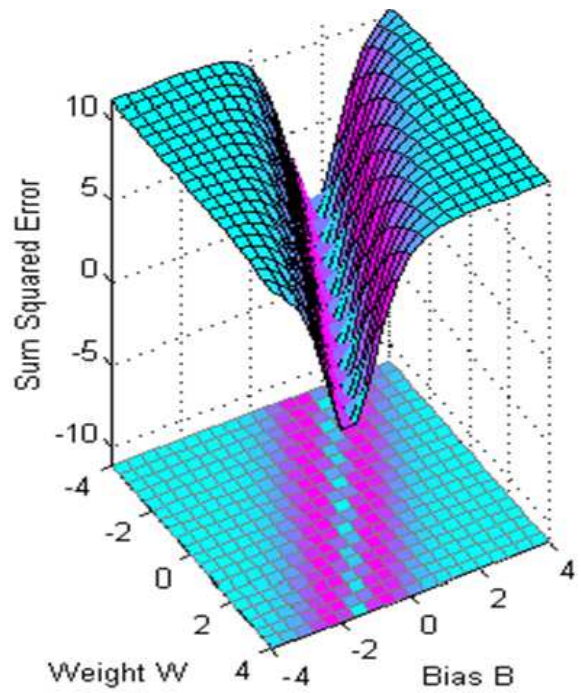

Figure 9c. Error Surface Graph for Fig. 9(a).

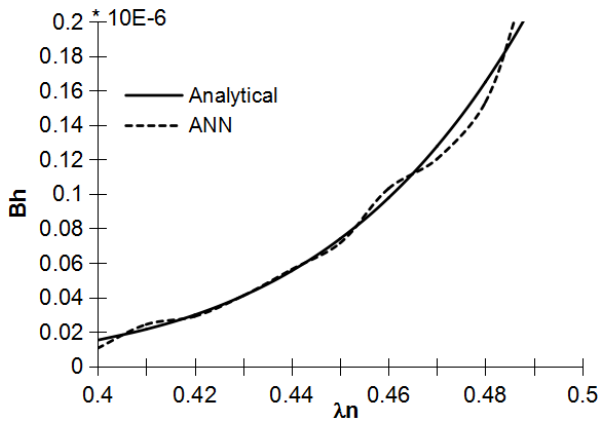

Figure 10a. B_h by varying λn for FSM.

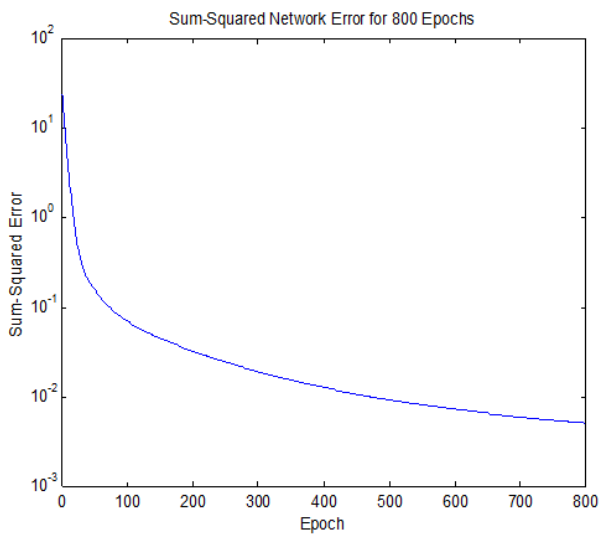

Figure 10b. SSE vs. Epochs for Fig. 10(a).

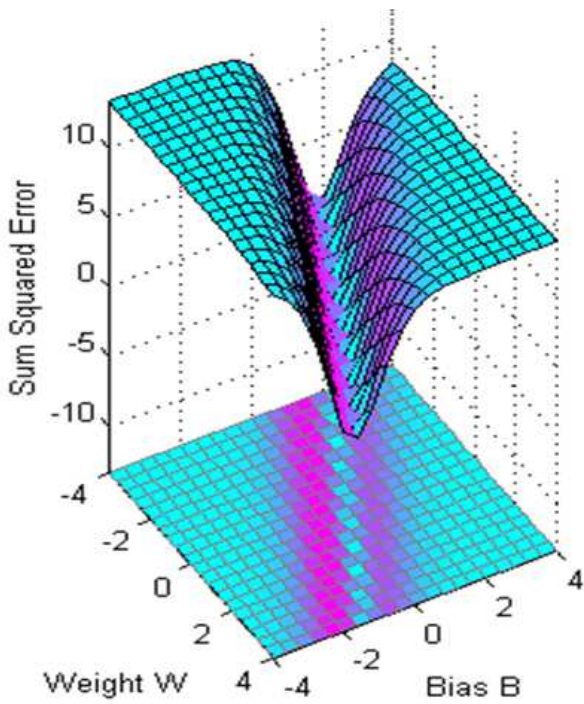

Figure 10c. Error Surface Graph for Fig. 10(a).

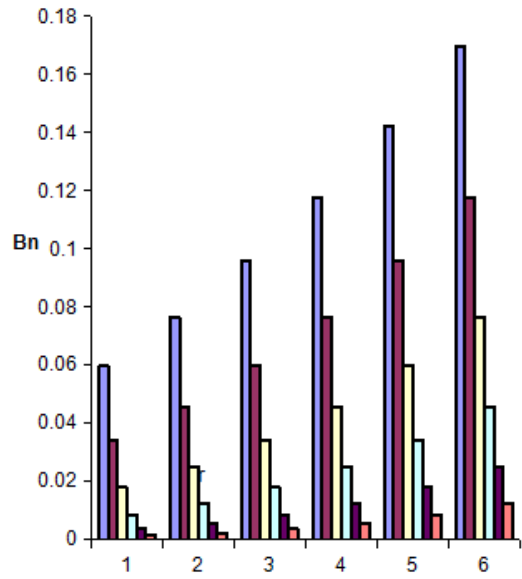

Figure 11a. B_n by varying C and r for ISM.

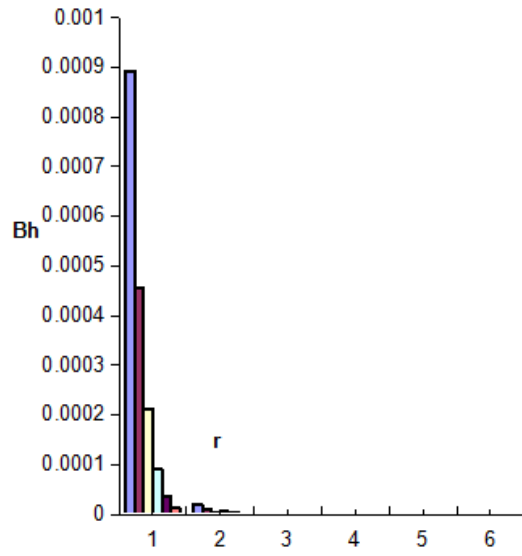

Figure 11b. B_h by varying C and r for ISM.

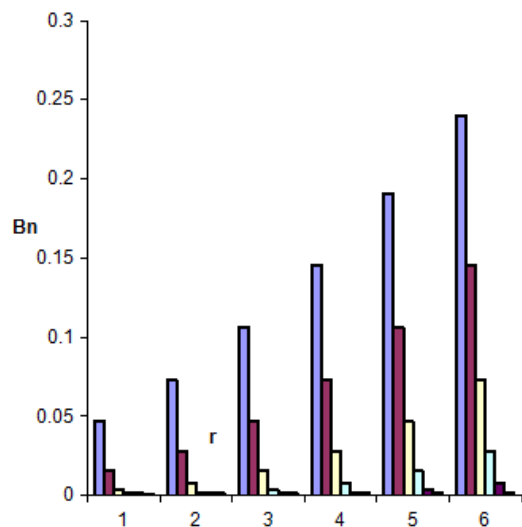

Fig. 11c. B_n by varying C and r for FSM.

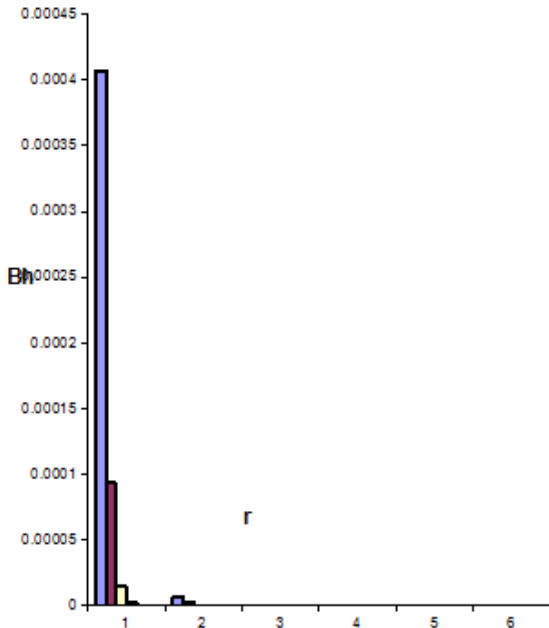

Figure 11d. B_h by varying C and r for FSM.

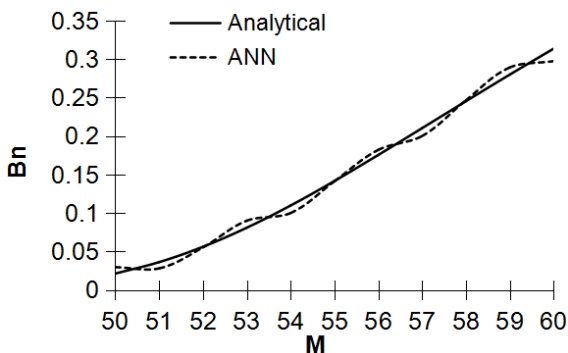

Figure 12a. B_n by varying M for FSM.

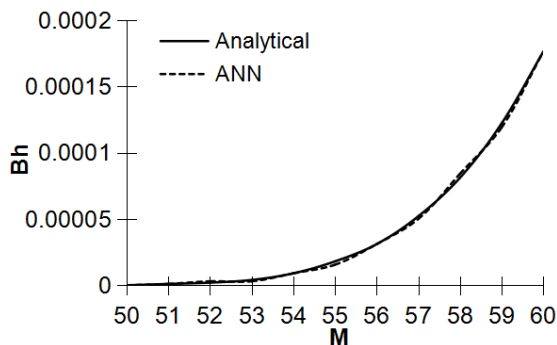

Figure 12b. B_h by varying M for FSM.

We conclude from the above results that the results obtained from the ANNs are quite accurate and are at par with the analytical results.

6. Conclusion and Scope of Further Research

In this paper, we have investigated the potential of artificial neural networks for analyzing the performance of a

cellular radio system. A prioritized channel scheme with subrating has been considered for the cellular system. The blocking probabilities of handoff and new calls have been determined by using a three-layer feedforward neural network. The backpropagation algorithm has been used for training the network.

The numerical simulations show that the results obtained by ANNs are comparable with the analytical results. We also conclude that once the ANN is trained against a data set, it takes less computational time than the conventional methods for calculating the required results which indicate that ANNs provide an easy and fast solution technique and are better than the conventional methods.

We have used ANNs for obtaining the performance measures of a cellular system. ANNs can be further used for taking handoff decisions for practical mobile cellular networks. Also, other soft computing techniques viz. Genetic Algorithms and Neuro Fuzzy Systems can be explored for modeling the performance of cellular networks.

References

- [1] Cichocki, A. and Unbehauen, R. (1993). Neural networks for optimization and signal processing, *Wiley, NY, USA*.
- [2] Clarkson, T. G., Ng, C. K. and Guan, Y. (1993). The pRAM: an adaptive VLSI chip, *IEEE Trans. Neural Networks, Special Issue on Neural Network Hardware*, 4 (3), 408-412.
- [3] Hopfield, J. J. and Tank, D. W. (1995). Neural computation of decisions in optimization problems, *Biol. Cybern.*, 52, 141-152.
- [4] Onyiah, C. G., Krasniqi, X. and Clarkson, T. G. (June 1996). Probabilistic RAM neural networks in an ATM multiplexer in solving engineering problems with neural networks, *Proc. International Conference Engineering Applications of Neural Networks*, 29-232.
- [5] Hecht-Nielsen, R. (Jan. 1989). Theory of back-propagation neural networks, *Proc. IEEE International Conf. Neural Networks*, Washington, USA, 1, 593-605.
- [6] Hornik, K. (1989). Multilayer feedforward networks are universal approximators, *Neural Networks*, 2, 359-366.
- [7] Tarraf, A. A., Habib, I. W. and Saadawi, T. N. (1993). Neural networks for ATM multimedia traffic prediction, *Proc. International Workshop on Applications of Neural Networks to Telecommunications*, 1, 85-91.
- [8] Moh, W. M., Chen, M. J., Chu, N. M. and Liao, C. D. (1995). Traffic prediction and dynamic bandwidth allocation over ATM: a neural network approach, *Comput. Commun.*, 18 (8), 563-571.
- [9] Drossu, R., Lakshman, T. V., Obradovic, Z. and Raghavendra, C. (1995). Single and multiple frame video traffic prediction using neural network models, *Computer Networks Architectures and Applications*, 146-158.
- [10] Edwards, T., Tansley, D. S. W., Frank, R. J. and Davey, N. (1997). Traffic trends analysis using neural networks, *Proc. International Workshop on Applications of Neural Networks to Telecommunications*, 157-164.

- [11] Chang, P. R. and Hu, J. T. (1997). Optimal nonlinear adaptive prediction and modeling of MPEG video in ATM networks using pipelined recurrent neural networks, *IEEE J. Sel. Areas Commun.*, 15 (6), 1087-1100.
- [12] Bolla, R., Davoli, F., Maryni, P. and Parisini, T. (Aug. 1998). An adaptive neural network admission controller for dynamic bandwidth allocation, *IEEE Trans. Syst., Man, Cybern. B., Special Issue on Artificial Neural Networks*, 28, 592-601.
- [13] Davoli, F. and Maryni, P. (Feb. 2000). A two level stochastic approximation for admission control and bandwidth allocation, *IEEE J. Sel. Areas Commun.*, 18 (2), 222-233.
- [14] Balestrieri, F., Panteli, L. P., Dionissopoulos, V. and Clarkson, T. G. (2000). ATM connection admission control using pram based artificial neural networks, *Computer Networks*, 34, 49-63.
- [15] Lin, P. and Lin, Y. B. (2001). Channel allocation for GPRS, *IEEE Trans. Veh. Tech.*, 50 (2), 375-387.
- [16] Fu, X., Bourgeois, A. G., Fan, P. and Pan, P. (2006). Using a genetic algorithm approach to solve the dynamic channel-assignment problem, *Int. J. Mobile Communications*, 4 (3).
- [17] Khanbary, L. M. O. and Vidyarthi, D. P. (2009). Channel allocation in cellular network using modified genetic algorithm, *International Journal of Artificial Intelligence*, ISSN 0974-0635, 3 (A09).
- [18] Siddesh. G. K, Muralidhara, K. N., Manjula. N. H. (July 2011). Routing in ad hoc wireless networks using soft computing techniques and performance evaluation using hypernet simulator, *International Journal of Soft Computing and Engineering (IJSCE)*, ISSN: 2231-2307, 1 (3).
- [19] Rajagopalan, N. and Mala, C. (2012). Optimization of QoS parameters for channel allocation in cellular networks using soft computing techniques, *Advances in Intelligent and Soft Computing*, 130, 621-631.
- [20] Jain, M. and Rakhee (2001). Queueing analysis for PCS with integrated traffic and sub-rating channel assignment scheme, *Journal of CSI*, 31 (2), 1-8.
- [21] Leca, C. L., Nicolaescu, L., and Rîncu, C. (2015). Significant Location Detection & Prediction in Cellular Networks using Artificial Neural Networks. *Computer Science and Information Technology*, 3, 81-89. doi: 10.13189/csit.2015.030305.
- [22] Silva, M., Carvalho, G., Monteiro, D., and Machad, L. S. (2015). Distributed Target Location in Wireless Sensors Network: An Approach Using FPGA and Artificial Neural Network, *Wireless Sensor Network*, 7, 35-42.