

# Development of a Heartbeat and Temperature Measuring System for Remote Health Nursing for the Aged in Developing Country

Blessed Olalekan Oyebola<sup>1</sup>, Ogunlewe Adeyinka Oluremi<sup>2</sup>, Toluwani Victor Odueso<sup>3</sup>

<sup>1</sup>Department of Computer Engineering Technology, Gateway (ICT) Polytechnic Saapade, Remo North, Nigeria

<sup>2</sup>Department of Electronic/Computer Engineering, Lagos State University, Lagos, Nigeria

<sup>3</sup>Department of Electrical/Electronic Engineering, University of Ibadan, Ibadan, Nigeria

## Email address:

blessedolalekan@gmail.com (B. O. Oyebola)

## To cite this article:

Blessed Olalekan Oyebola, Ogunlewe Adeyinka Oluremi, Toluwani Victor Odueso. Development of a Heartbeat and Temperature Measuring System for Remote Health Nursing for the Aged in Developing Country. *Science Journal of Circuits, Systems and Signal Processing*. Vol. 7, No. 1, 2018, pp. 34-42. doi: 10.11648/j.cssp.20180701.15

**Received:** December 4, 2017; **Accepted:** December 13, 2017; **Published:** January 11, 2018

---

**Abstract:** Obtainable remote nursing systems have some identified glitches including inept data extraction and dynamic tuning of data to preserve the quality of data transmission exclusively for the aged. This paper presents an alternative designed architecture of a microcontroller based heartbeat and body temperature monitoring system using fingertip and temperature sensor as a solution to some of the identified challenges of existing technology that uses network between the patient and doctor to enable remote monitoring of aged patient for medical attention. Appraisal of the device on real signals shows accuracy in heartbeat measurement, even under intense physical activity for the aged.

**Keywords:** Aged, Heartbeat, GSM, Remote, Nursing

---

## 1. Introduction

Heartbeat is the number of heart beats per unit of time which is generally stated in beats per minute (bpm). Heart beat can change as the body needs to absorb oxygen and release carbon dioxide. It alters during exercise or at rest. The measurement of heart beat is mostly used by medical professionals as a primary test to help in the diagnosis and tracking of the medical conditions [1].

It is also used by the individuals who are involved in intense physical training, such as athletes who are greatly involved in Nursing of their heart rate to achieve maximum efficiency. Due to sudden change in lifestyle and unhealthy eating habits, the incidents of heart and vascular diseases are found to increase in a dramatic manner. Moreover, heart problems are being increasingly diagnosed on younger patients. Coronary heart disease is now considered as one of the leading cause of death around the globe. Diagnosis and treatment of patient is always welcomed by medical community. Heart rate is usually measured in controlled environment in clinics, but it is of great need that a system

must be designed so that the patient will be able to monitor their health in their home as well. This will enhance the system performance while offering the advantage of portability over other conventional systems [1].

A heart beat monitor (HBM) is a simple and economical device which calculates a sample of the heart rate signal and measures the beats per minute which allows utilization of the information for easy Monitoring of heart condition. The HBM devices employ electrical and optical methods as means for detecting and achieving the heart signals. So, the wireless technology is utilized in order to meet the requirement of remote control and patient monitoring. The remote patient nursing is a technology which provides us with the opportunity to monitor the patient outside the hospitals by reducing the need of visiting the patient which saves both the time and money of patient and doctor while increasing the efficiency along with the reliability of health services [1].

Heartbeat and body temperature are very important parameters that are routinely measured whenever a patient

arrives in a hospital which makes heartbeat one of the very significant property of cardiovascular system. The heart rate of a healthy adult at rest is around 72 bpm [2]. Athletes normally have lower heart rate than less active people which leads us to the fact that the persons who are more excessively involved in exercise or physical training are more likely to have less heart rate than those who are not involved in intense exercise. Small babies tend to have much higher heartbeat (120 bpm) in comparison to older children (90 bpm). Heart rate increases during exercise while it returns back to normal rate slowly after the exercise is finished. The rate at which the heart rate returns back to normal value is an indication of the fitness of a person. If the heart rate is lower than the normal heart rate, then it is normally an indication of bradycardia while if the heart rate is higher than the normal heart rate, then the condition is known as tachycardia [3].

Similarly, the body temperature also changes from one person to another and varies throughout the day. The body temperature is found to be lowest in the early morning while it is highest during the early evening. It is necessary to monitor the changes regularly. An average human adult has normal body temperature of around 37°C or 98.6°F [4]. However, it is difficult to define an accurate value of body temperature as it varies according to daytime, age and physical state of a person. So, the normal body temperature of a healthy person can be 36.1°C (97°F) in the early morning and can rise up to 37.2°C (99°F). Hence, normal range of body temperature of a healthy adult varies between 97°F and 100°F or 36.1°C and 37.8°C [5]. The temperature sensor used here is LM35. This temperature sensor generates an analog output voltage that is proportional to the temperature. So, this temperature sensor requires an analog to digital converter to convert the analog output voltage to a digital form [6]. For this reason, a microcontroller of model PIC16F887 is used to convert the analog value to a digital form in order to send the measured data to a remote end. A wireless heartbeat and temperature monitoring system has been proposed before using radiofrequency (RF) module [7]. But it has some limitations as described in section 6 and 7. With the advancement of technology, both quality of security [8] and health in human life is increasing day by day. This paper presents the design of a very low cost remote patient nursing system which will measure heart rate and body temperature of an individual and the measured data will be sent to a remote end where the data will be displayed on a mobile device using GSM module. This device will help both the patient and doctor during emergency period by saving both time and cost of patient and physician.

Traditionally, it was a custom to get these vital signs measured during a visit to the doctor. With advances in medicine and technology, this concept has adapted. There are many devices available in the market today that allow patients to monitor their own health on a regular basis from the comfort of their home. These devices are having a huge impact on health care costs as they are reducing the time and resources of medical physicians and facilities required by patients. This is advantageous for both patients and

physicians. Patients can monitor their health regularly and adjust their diet and physical exercise as needed to keep their vitals in balance. Health care professionals can access this information from their GSM via wireless network and can check their patients' vitals at their own time. If they notice abnormalities, they can always schedule an appointment with their patients. There are very few in-home monitoring devices in the market that are accurate, easy, and safe to use, while being of low cost to the customer. The objective of this work is to develop such a device. At the end of this study, a digital heart rate and temperature monitor would have been designed, constructed and tested working using GSM Module. The goal of the main work is to develop a low cost, low power, reliable, non-intrusive, and non-invasive vital signs monitor that processes and analyses the data acquired from sensors to determine if they are within a "normal" range and to transmit this data to the user's cell phone using GSM Module and store it there. This data can then be obtained by the user or a health care professional anytime via wireless network for individuals over the age of 65 years.

## 2. Further Studies

Some of the heartbeat and temperature measuring system for remote health monitoring designs have been made using different modules to assist in improving human health. This paper aim at providing an alternative way of deploying heartbeat and temperature measuring system in remote health nursing for the aged in developing country.

### *Heart Beat and Body Temperature Monitor*

Initial research was conducted to determine the types of vital signs that are routinely measured during a visit to a doctor. These vital signs are: body temperature, pulse rate, respiration rate (rate of breathing) and blood pressure. As part of my work. It was decided to design and build sensors that measured two of these vital signs.

The market demand for this type of device was determined and research on similar monitoring devices that are currently sold was performed. According to a report from Berg Insight, the market for home health monitoring was worth about \$11 billion in 2008 [9] and [10]. Devices currently sold that offer similar monitoring capabilities are:

- i. "Life Guard – A Wearable Vital Signs Monitoring System" developed by NASA AMES Astrobionics [10],
- ii. Spot Vital Signs LXi developed by Welch Allyn, and
- iii. CASMED's 740 Vital Signs Monitor [10].

Major drawbacks with these devices are that they are not very easy to use, somewhat intrusive, and, of course, very expensive. From researching prices of similar devices on E-Bay, they cost anywhere from \$500 to \$5000. After considering these factors, a key goal of this work became to design sensors that would not only efficiently and accurately monitor the vital signs, but also be cost-effective.

The RF module worked only for limited range about 100m in an open space but our research found out that it worked only for about 14m with occasional inaccuracies and sometimes the signal was hard to catch. GSM module surpasses this

drawback as it could send data to any location where network was available. The RF module had another serious disadvantage of initial cost. The initial cost of setting up the device with RF module is very high compared to GSM module which has low initial cost as it requires only a GSM module and a mobile device. The RF module does not depend on the network of mobile operator while GSM module depends on it. The RF module uses wireless serial data link while GSM module uses mobile phone protocol. Once the device is set up with RF module, there is no need to pay any extra cost. However, the running cost of RF module was found out to be very low compared to GSM module. The GSM module requires a SMS to be sent to a mobile device which may require paying for SMS to the mobile operator unless the government takes an initiative to make the service free of charge which would increase the reliability of the device. The

RF module requires a license after certain range from the government depending upon the geographical location while GSM module does not require license. The license needs to be purchased which adds the cost to the system implemented with RF module. The RF module does not require a SIM card whereas GSM module requires a SIM card.

### 3. Technique Used

Various technologies that were currently used to monitor these vital signs were examined and the most effective sensing techniques for this work were determined. It was resolved that one of most effective way of measuring body temperature is by using a photo diode and a bright LED. The overall work was done in two main stages: software and hardware development.

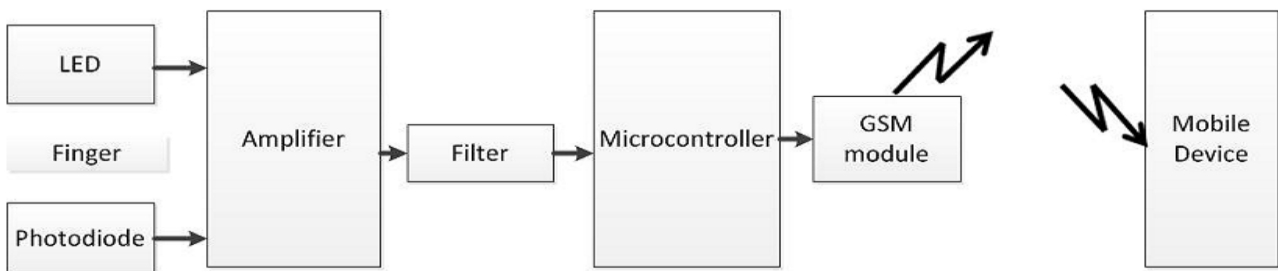

Figure 1. Block diagram of the Complete System [11].

#### 3.1. Hardware Development

The GSM technology in heartbeat and temperature measuring system for remote health nursing is made up of four main components (see Figure 1): microcontroller, sensory measuring unit (a photo diode, a bright LED and LM35 temperature sensor), wireless module and digital display unit.

##### 3.1.1. Micro-Controller

PIC16F877A microcontroller (Figure 2) is a small computer on a single integrated circuit consisting of a relatively simple CPU combined with support functions such as a crystal oscillator, timers, watchdog, serial and analog I/O etc. Neither program memory in the form of NOR flash or OTP ROM is also often included on chip, as well as a, typically small, read/write memory. Microcontrollers are designed for small applications. Thus, in contrast to the microprocessors used in personal computers and other high-performance applications, simplicity is emphasized. Some microcontrollers may operate at clock frequencies as low as 32 kHz, as this is adequate for many typical applications, enabling low power consumption (milli watts or microwatts). They will generally have the ability to retain functionality while waiting for an event such as a button press or other interrupt; power consumption while sleeping may be just nanowatts, making many of them well suited for long lasting battery applications. Microcontrollers are used in automatically controlled products and devices, such as automobile engine control systems, remote controls, office machines, appliances, power tools and toys. By reducing the size and cost compared to a design that uses a separate microprocessor, memory and input/output devices, microcontrollers make it economical to digitally control even more device and processes.

Figure 1 displays the block diagram of the complete system in which the device consists of a PIC16F887 microcontroller for measuring and transmitting the data to a remote end on a mobile device. The measured data of

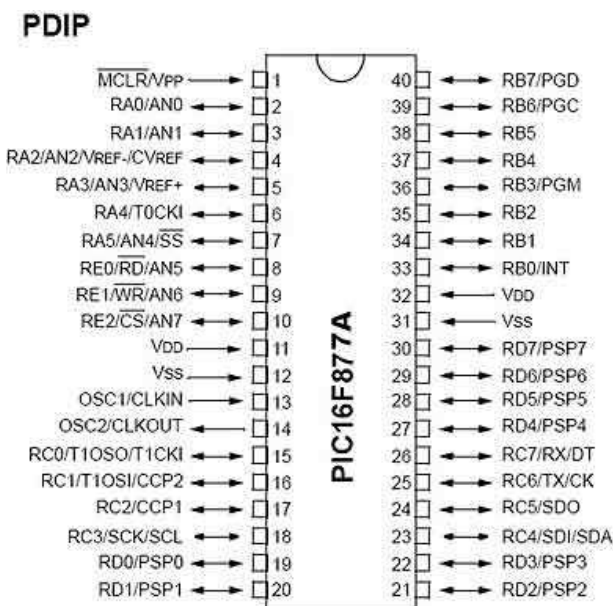

Figure 2. PIC16F877A pin configuration.

heartbeat and body temperature is directed to a remote end with one GSM module. For measuring heartbeat, the device utilizes a photo diode and a bright LED along with an amplifier and a filter circuit. For measuring the body temperature, the device uses LM35 temperature sensor. The device measures heartbeat and temperature of the body and transmits the data wirelessly with the help of the GSM module. The data, which consists of heartbeat and body temperature, is received at a mobile device. Thus the data can be stored and viewed for future reference.

### 3.1.2. Sensory Measuring Unit

Heartbeat is measured with the help of fingertip sensor which consists of an infra-red (IR) light emitting diode transmitter and an IR photo detecting receiver. The IR light

passes through the tissues and variations in the volume of blood within the finger determine the amount of light that is incident on the IR detector.

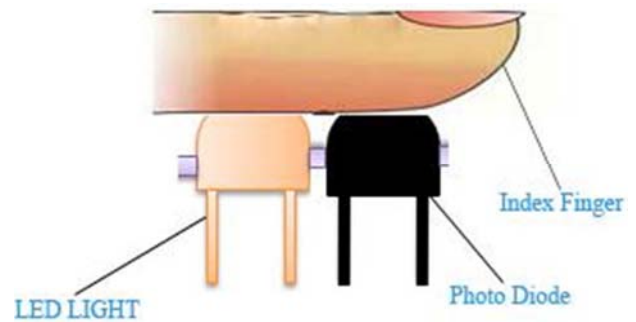

Figure 3. Arrangement of the sensor [11].

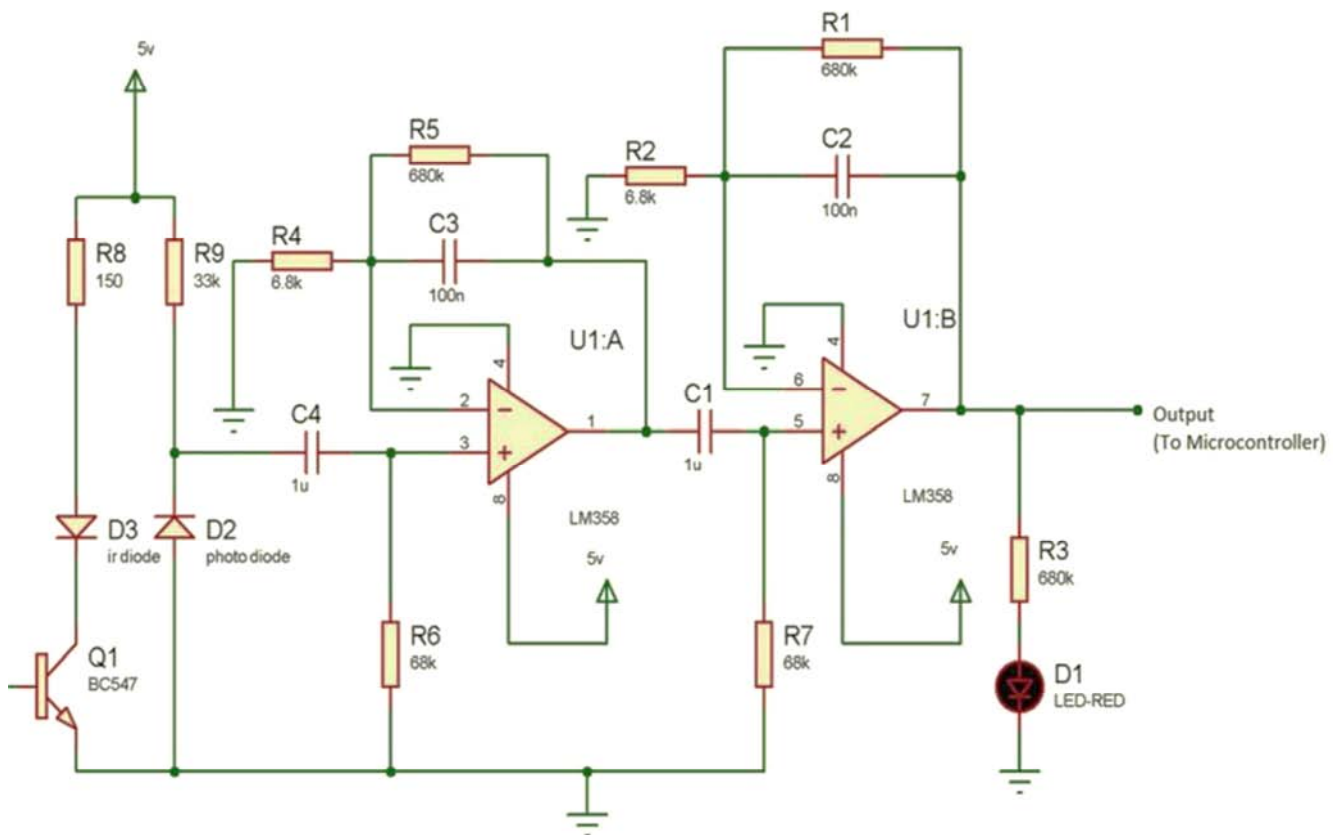

Figure 4. Circuit arrangement for amplifier and filter.

Figure 3 shows the arrangement of sensors for measuring the heartbeat of a patient. The device employs optical technology to measure heartbeat of patient. As shown in the Figure 3, both the IR transmitter and receiver could be placed on the same plane and the finger would function as a reflector of the incident light. The IR receiver monitors the reflected signal in this case. The IR filter of the photo transistor reduces interference from the mains 50Hz noise. The IR LED is forward biased through a resistor to create a current flow. The fingertip sensor consists of a photodiode and a bright LED. The LED and the photodiode are attached in an adjacent position so that the finger acts as a reflector for infra-red light. The light from bright LED collides with the

tissues of the finger that is put above the bright LED and the photo diode. The blood is continuously changing inside the tissues of the finger which results in the variation of blood due to which there is variation of reflected light that the photo diode is going to detect. The bright LED and the photodiode are attached tightly so that they could have tight grasp while detecting the heartbeat. This signal is very weak that it cannot be detected by the microcontroller directly. Thus, the signal is amplified using an operational amplifier, Figure 4. The operational amplifier used for this purpose is LM358. This operational amplifier is provided with two of the independent high gain, frequency compensated operational amplifier which is designed to function from a

single supply over a wide range of voltages which means that this amplifier is capable of amplifying the signal in two stages making the device able to detect the signal and in turn measure the heartbeat. This device uses two stages for amplification process as shown in Figure 4. This device uses non-inverting amplifier for amplifying purpose in both the stages. The operational amplifier can be considered as a low power quad operational amplifier. The signal is amplified to an appropriate voltage level so that the pulses can be counted by the microcontroller. The signal generated from the photo diode also contains noise which is required to be filtered otherwise the obtained signal will contain noise of some types making the measurement complex. Moreover, the interference produced due to the movement of artefacts and the mains supply of 50Hz can also affect the signal. The standard ECG signal of heartbeat has frequency component which varies in the range of 0.05-200Hz [12]. When this signal is filtered, the frequency component varies in the range of 0-50Hz [7]. Thus, the filtration does not affect the quality of the signal. The information contained in the signal is not lost. A red LED is placed at the output of the amplifier and filter stage to show that the device is working for the measurement of heartbeat. Here, the resistance of R5 is equal to the resistance of R1 while the resistance of R2 is equal to the resistance of R4. The gain of each stage is found to be 101 after calculation while cut-off frequency is found to be 2.34 Hz. This value is optimum to measure the heartbeat without any problem.

$$R_5 = R_1, R_2 = R_4$$

$$\text{Gain of each stage} = \frac{R_5}{R_4}$$

$$\text{Cut - off frequency} = \frac{1}{2\pi\sqrt{RC}}$$

The temperature monitoring unit consists of the components that are required to measure the temperature of the body. This unit comprises of a temperature sensor which measures the temperature of the body and is connected directly to a microcontroller. The temperature sensor that is used in this circuit is LM35 for the measurement of the body temperature. This temperature sensor is an analog sensor which produces an analog voltage by sensing the temperature. This sensor is held by the finger for a while (about 15 sec) in order to measure the body temperature. The body temperature on the body surface is about 1 degree centigrade less than the temperature of other parts. The analog voltage produced by the LM35 temperature sensor is directly proportional to the body temperature. The analog voltage needs to be converted to a digital value. For the conversion, the microcontroller PIC16F73 is used, which has a built-in analog to digital converter due to which an extra component for converting analog voltage to digital voltage is removed and the circuit configuration becomes less bulky. The digital equivalence of analog voltage produced by LM35 sensor can now be used by the microcontroller for further processing. The microcontroller

receives the data in analog form and converts it into digital form then sends it to the GSM module so that the data can be sent to the remote end. At the receiving end, a mobile device which utilizes the GSM system receives the message. The message received at the mobile device is displayed at the screen along with the data of heartbeat. The data shown in the screen also shows the date and time of the measurement. The LM35 is a precision integrated circuit temperature sensor that is used here to measure temperature. The electrical output voltage of LM35 is linearly proportional to the Celsius or centigrade temperature. The LM35 has an advantage over linear temperature sensors calibrated in degree Kelvin, as it is not required to subtract a large constant voltage from its output to obtain convenient Centigrade scaling. Besides, the LM35 does not require any external calibration or trimming to provide typical accuracies of +/- 1/4 degree C at room temperature and +/- 8/4 degree C. The trimming and calibration are done at wafer level. So, it is an inexpensive device. It can be used with single power supplies, or with plus and minus supplies. As it draws only 60 µA from its supply, it has very low self-heating, less than 0.10 in still air. Thermistor can also be used for temperature measuring. Another reason for using LM35 is that it accurately measures the temperature in comparison to thermistor and it is not subjected to oxidation as the sensor circuitry is sealed. Besides, the output voltage of LM35 does not need to be amplified. The low output impedance, linear output and precise inherent calibration of the LM35 make its interfacing to control circuitry very easy. Moreover, the LM35 is rated to operate over a -55°C to +150°C temperature range. The output voltage varies by 10 mV in response to every °C rise/fall in ambient temperature, i.e. its scale factor is 0.01 V/°C. For measuring temperature of a patient, the left pin and right pin of LM35 is connected to the power (5V) supply and ground respectively. The middle pin generates analog voltage that is directly proportional to the temperature. Here, analog voltage is independent of power supply. Thus, the middle pin is connected to the microcontroller PIC16F73 at port A for further processing. The microcontroller has ADC in it and it keeps the digital data in the memory.

### 3.1.3. Wireless Module

The GSM module used in this work is SIM 908-C. This module is intended for covering global market. It works at a frequency of GSM 850MHz. It offers best class acquisition and tracing sensitivity features, Time to first fix (TTFF) and accuracy. The size of this module is 50mm x 33mm x 8.8mm. It can meet almost all the requirements for space in user applications, such as M2M devices. This module has a 60-PIN DIP connector (see Figure 5) and consists of a serial port and a debug port that can help users to easily develop the user’s applications. Moreover, this module comes with power saving technique so that the consumption of current is as low as 1 mA during sleep mode.

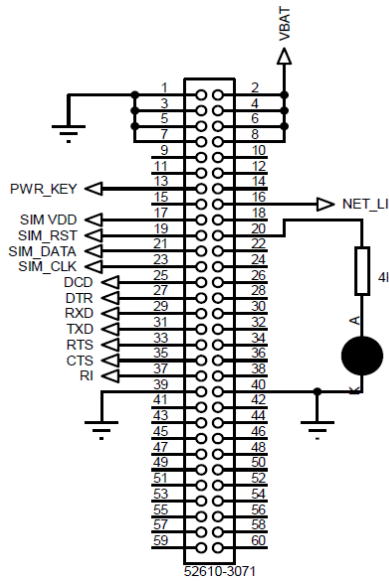

Figure 5. The connecting pin for the GSM module.

Figure 5 demonstrates the detailed pin diagram of GSM module. It shows that the pin 2, 4, 6 and 8 are connected to

VBAT while pin 16 of the module is connected to Net Light which shows the network status. The LM35 sensor is connected to the microcontroller PIC16F887 via port A at pin 2. This sensor has three pins. The right pin is connected to the ground and the left pin of this sensor is connected to the power supply (5V) while the middle pin is connected to the microcontroller which gives us the analog voltage. The microcontroller has ADC in it and it does further processing and sends the measured data to the remote end via GSM module. Capacitor is used at each input terminal to block the dc component in the signal. Finally, a red LED is placed at the output of this unit to indicate the pulse in analog form [13]. The measured heartbeat is sent to the microcontroller via pin 4 of port A.

### 3.1.4. Digital Display Unit

LCD (Liquid Crystal Display) screen is an electronic display module, Figure 6 and 7. The module is preferred over seven segments and other multi segment LEDs for its less cost and easily programmable; it can display 16 characters per line. The LCD data register stores data to be displayed. The data is the ASCII value of the character to be displayed on the LCD.

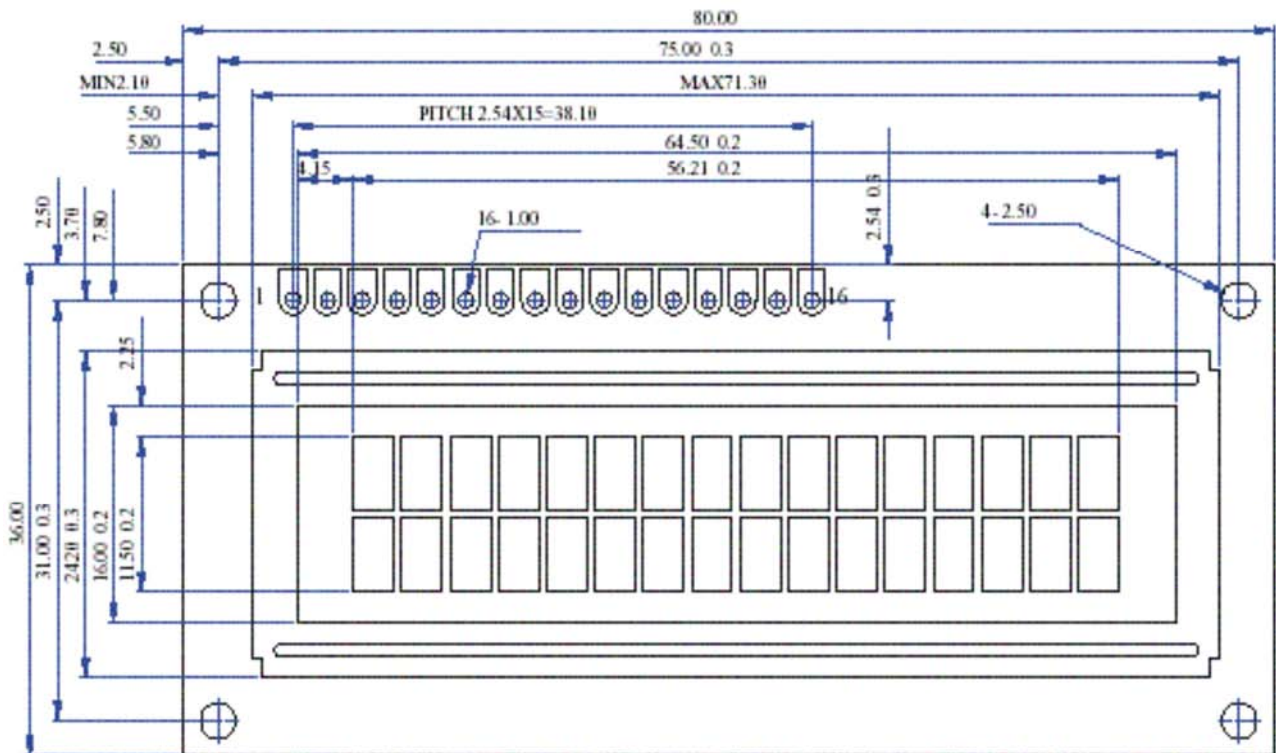

Figure 6. 16X2 LCD display circuit.



Figure 7. 16X2 LCD display.

### 3.2. Software Development

The system code was developed on MicroC Pro and Proteus 8.1 platform. The design sequence or algorithm and steps were as illustrated in Figure 8.

The system program algorithm

- a) Start
- b) Microcontroller configuration
- c) Temperature sensor initialization



- d) Heart pulse rate configuration
- e) GSM module configuration
- f) Copy EEPROM phone number to RAM location
- g) Begin infinity loop
- h) If button pressed & finger detected
  - i) LCD display “Do not remove”
  - ii) Count the finger pulse for 15 second
- i) Then LCD display “Place the Temperature sensor in the Armpit and press Button” a. Read the temperature for 4minutes
- j) Display the temperature and BPM on the LCD and send these value as SMS to the operator
- k) End infinity loop
- l) End

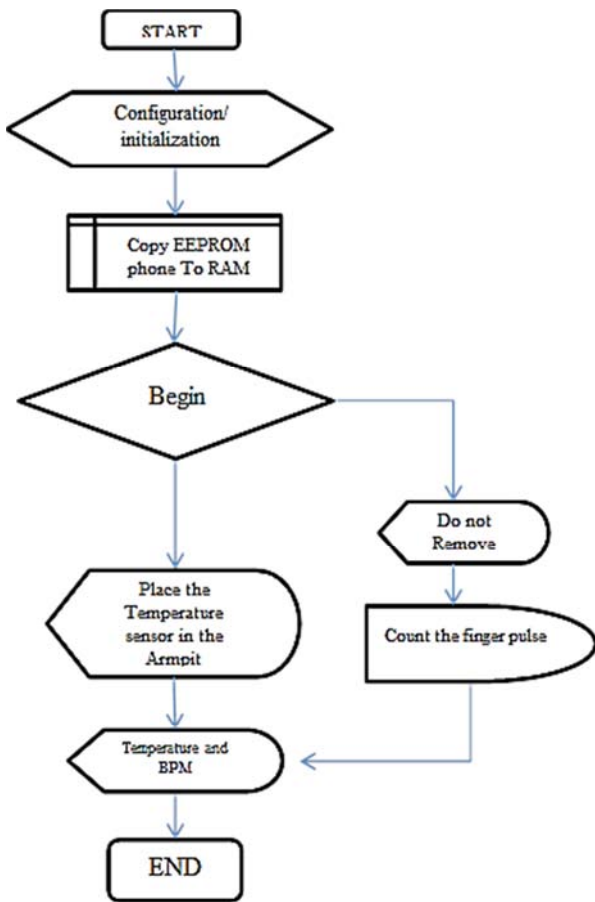

Figure 8. The system flowchart.

### 4. Result and Testing

The output from sensor and amplifier circuit was connected to the microcontroller. The observed output signal was periodic ac signal with amplitude varying from peak to peak according to person. A model sinusoidal signal and the output from sensor were fed to microcontroller and the counted pulse rate was successfully sent via GSM module. The counted signal from the sensor to measure the heartbeat was relatively a weak

signal which needed to be amplified and filtered before it was sent to the microcontroller. So, the signal was amplified using an operational amplifier. LM358 was used to amplify the signal. The amplified signal was then filtered to get the desired output of heartbeat which was then sent to the microcontroller for further processing. The microcontroller then sent the received data of both heartbeat and temperature of a patient to a remote end via GSM module.

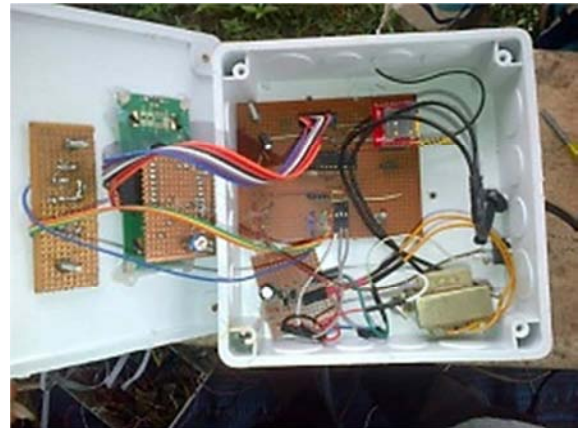

Figure 9. Circuit implementation.

The implemented circuit is as shown in Figure 9 and 10. These figures show all the circuit components which are required to monitor the patient remotely. It consists of the devices which measures heartbeat and body temperature. The use of this device is very simple. At first, the cord is connected to the DC power supply. Wait for the device to be ready. It may take some time depending upon the availability of the network. When the device is ready, put your index finger on the heartbeat sensor and the LM35 sensor. Then, type “STATUS” on the mobile device and send to this device. After you send the message, wait for the device to respond. The device will receive the message and send the measured data of heartbeat and body temperature to the mobile device. The completed work is as shown in Figure 10.

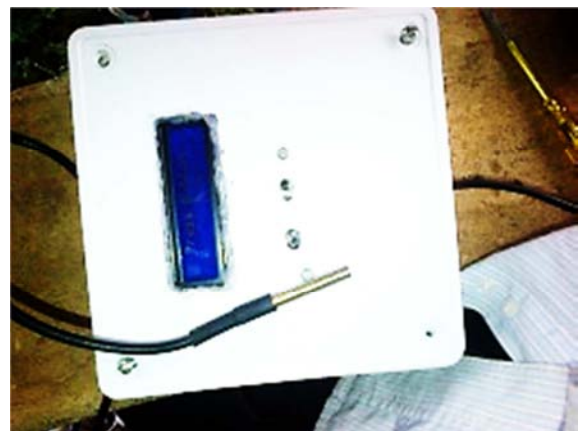

Figure 10. Completed package of Heartbeat and Temperature Measuring System for Remote Health Nursing.

Table 1. Testing by comparison.

Test Specimens	Result of Heartbeat and Temperature Measuring System for Remote Health Nursing for the Aged		Result Of Heartbeat And Temperature Measuring System Using Electrocardiography	
	Heartbeat (BPM)	Temperature (°C)	Heartbeat (BPM)	Temperature (°C)
Patient A	20	35.87	22	34.1
Patient B	22	34.23	23	32.5
Patient C	21	35.11	27	36.2
Patient D	25	32.54	30	32.5
Patient E	19	35.23	25	35.9

This work reduces time wastage in the hospital and provides quick and accurate result in health monitoring system mostly for poor road and far distanced developing country' dwellers but due to the poor telecommunication network system there may be delay in some cases when sending and receiving results. The device can be used in developing area. The data sent to the mobile number of the receiver can be backed up for future use. See Table 1 for a typical test result of the system compare to that with Electrocardiography. The procedures for operating the device involve:

Step 1: insert SIM into the GSM module

Step 2: power on the system

Step 3: send setc as text message to the number in GSM module (this makes the receiving phone number changeable to users' choice)

Step 4: wait for the sim to receive the message

Step 5: off and re-on the system and follow screen instruction to do the text

Step 6: press the button

Step 7: put your big finger on the black button

Step 8: do not remove finger until you get a result for heart beat

Step 9: place temperature sensor in armpit and press the button. This will take about four minuets

Step 10: wait till the temperature is recorded.

The device will display the result and send it to the registered GSM number.

The heart beat monitor counts the heart beat rate in beats per minute (bpm) for specific interval and transfers the calculated rate via GSM module and sends it to a remote end where it displays the observed data in a mobile display. Optical sensor with combination of infrared light emitting diode (IR LED) and IR photodiode senses the pulse rate that produces weak output of analog signal. The signal is then amplified and filtered and fed to the microcontroller input. The microcontroller processes the input and calculates heart beat rate in beats per minute. Thus, calculated heart beat rate is displayed in liquid crystal display (LCD). The data is also displayed on the screen of a mobile device by using GSM module.

LM35 is used as a temperature sensor in this work which measures the temperature of the body and the measured data is fed to the transmitter module. Wireless system is used to transmit the measured data to a remote location. The transmitter transmits the calculated beat rate and is received in another terminal called receiver module. Inconvenience of using wire is avoided in this research. Finally, the data are displayed in the mobile screen at the receiving end where the specialist or

physician can analyze the data and will be able to provide aid.

## 5. Conclusions

The developed system reliably measured heartbeat and temperature of a patient and send the recorded results to a remote end nurse for prompt medical attention; mostly viable for the aged in a far developing communities with inaccessible road at a reasonable cost for monitoring. It utilized remote patient monitoring system technology which enabled the monitoring of patients outside of clinical settings and led to increasing access to health care as well as decreasing the health care delivery costs. Nowadays, most of the systems work in offline mode. The research utilized two sensors for measuring heartbeat and temperature of a body. These sensors are controlled by the microcontroller for measurement of heartbeat. The device uses the optical technology to detect the flow of blood through the finger. The developed system is reliable, economical and user friendly.

## References

- [1] Mohammad, Wajih Alam; Alam, Tanin Sultana; Mohammad Sami. (2016). A Heartbeat and Temperature Measuring System for Remote Health Monitoring using Wireless Body Area Network. International Journal of Bio-Science and Bio-Technology, 171-190.
- [2] A. B. Donnersberger. (2009). A Laboratory Textbook of Anatomoy and Physiology. Illinois: Jones and Bartlett Publishers.
- [3] D. Mukherjee, K. Gupta, M. Pandey and A. Agrawal. (2013). Microcontroller based Cardiac Counter System. International Journal of Engineering, Applied and Management Sciences.
- [4] Eisman, L. (1972). "Biology and Human Progress".
- [5] Simmers, L. (1988). Diversified Health Occupations. Canada: Delmar.
- [6] R. Trivedi, G. Mathur and A. Mathur. (2011). A survey on Platinum Temperature Sensor. International Journal of Soft Computing and Engineering, vol. 1.
- [7] C. K. Das, M. W. Alam and M. I. Hoque. (2013). "A Wireless Heartbeat and Temperature Monitoring System for Remote Patients. International Conference on Mechanical Engineering and Renewable Energy. Chittagong, Bangladesh.
- [8] M. S. Alam, M. W. Alam and T. Sultana. (2013). "RFID based Room Automation". International Conference on Mechanical Engineering and Renewable Energy. Chittagong, Bangladesh.



- [9] Brian, D. (2009, September 25). Home Health Monitoring. Retrieved from Mobi Health News: <http://www.mobihealthnews.com/4568/home-health-monitoring-was-11b-market-in-2008>.
- [10] Abhijit, G. K., Swati, B. N., Bhavan, B. M., Pooja, A. K., & Pratiksha, D. (2016). Multi-Purpose Biomedical Circuit. Volume 2 (12).
- [11] Mohammad Wajih Alam, Tanin Sultana, Mohammad Sami Alam. (2016, September 22). Research Gate. International Journal of Bio-Science and Bio-Technology. Retrieved from A Heartbeat and Temperature Measuring System for Remote Health Monitoring using Wireless Body Area Network: [https://www.researchgate.net/figure/299398898\\_fig1\\_Figure-1-Block-Diagram-of-the-Complete-System](https://www.researchgate.net/figure/299398898_fig1_Figure-1-Block-Diagram-of-the-Complete-System).
- [12] Das, C. K., Alam, M. W., & I., H. M. (2014). A Wireless Heartbeat and Temperature Monitoring System for Remote Patients.
- [13] Mohammad, W. A., Tanin, S., & Mohammad, S. A. (2016). A Heartbeat and Temperature Measuring System for Remote Health Monitoring using Wireless Body Area Network. 8 (1).