



The Exploratory Study on Thinking Path Schema of English Translation for Chinese Classics --- Exemplified by the Analects in English Versions

Xiaojuan Peng

Department of Translation, School of Foreign Languages, Yancheng Teachers University, Yancheng, China

Email address:

20120908xjp@sina.cn

To cite this article:

Xiaojuan Peng. The Exploratory Study on Thinking Path Schema of English Translation for Chinese Classics --- Exemplified by The Analects in English Versions. *International Journal of Applied Linguistics and Translation*. Vol. 4, No. 2, 2018, pp. 40-45.

doi: 10.11648/j.ijalt.20180402.13

Received: August 21, 2018; **Accepted:** September 26, 2018; **Published:** October 19, 2018

Abstract: In view of the deficiency of holistic study on English translation of Chinese classics and the present holistic study covering a too wide range, it's few to discuss the integral thinking path schema of English Translation for Chinese Classics. Here, it's necessary to carry out thinking path schema study of English translation for Chinese Classics in an overall view by some detailed examples. Through the methods of analyzing and comparing the cases in English versions of *The Analects* by Hongming Gu, James Legge and Guozhen Wu, it summarizes all process elements involved into the thinking path of translating Chinese Classics into English from general macro angle, in the supplementary sublimation of translation integrants from Partial Translation Theory by Holmes. That naturally deduces and extracts the possible existed interactive relationship among translators, source language, target language and the recipients. And it proposes universal applied thinking path schema of English translation for Chinese Classics in order to be referred for translation education, practices and studies.

Keywords: English Translation of Chinese Classics, Thinking Path of Translation, Schema, English Versions of the Analects

1. Introduction

For the Chinese National Translation Studies Forum of 2014, Hong Wang thinks it's extremely necessary to have the holistic study on the English translation of Chinese classics [1]. Domestic and overseas scholars all refer to some factors of translation process in holistic study, but the complexities and peculiarities of Chinese classics have determined their English translation versions are in the lack of pertinent translation summary on thinking path and the visual schema [2-5]. Roger Bell builds micro translation process schema by the research findings of psychology and cognitive science in the guidance of linguistics to present the translation process and the elements of translation activities directly, including the detailed translation steps of analysis procedure, comprehensive procedure, text representation and synthesizing procedure, sense, sense relationship, the producing of sense, text information processing, text processing skill and so on aspects [6]. His research has lineage division of text by presenting translating clause

process from the linguistic angle, but sentence is not the only translating unit, for those unique Chinese traditional words, it can not be applied. Fenghua Li suggests to enriches and develops the translation theory for Chinese cultural classics translation by context theory, multisystem theory and functional equivalence theory [7, 8], but it still lacks the holistic horizon to translation process. Hereby, it assumes the thinking path schema of translating Chinese classics through the cases explanation of English versions of *The Analects*, by some elements, such as translation methods, scope, text types, and translation period of Partial Translation Theory from Holmes [9]. Meanwhile, it supplements some typical elements relevant to Chinese classics' English translation process to contribute to translation education, practice and studies.

2. The Integrants Involved into English Translation Process of Chinese Classics

2.1. For Translators

English Translation of Chinese Classics requires comprehensive attainment of Chinese ancient culture, profound understanding of classical Chinese, and excellent and ingenious translation ability. The main translators participated in the translating Chinese classics should be qualified with abundant relevant translation knowledge (TK), including bilingual common knowledge accumulation, bilingual transformation skills, bilingual linguistic data memory and solid cultural comprehension. Translators might be influenced by politics, economy, culture, history, the past versions, transmission effects, the pre-translation influence (PRI) from some readers and audiences. At the same time, the translation intention (TI) of individuals, groups and society would draw their attention to examine and weigh the producing and publishing time of the source text. Driving for realizing personal values, transmitting ideologies among societies and cultures, achieving communication and so on translation objectivities (TO), translators would adopt some translation methods (TM), such as by manpower, machine, machine-aided translation, interpreting and translating, to consider the translation period (TP), and presuppose the translation works conforming to expression levels of works themselves, value system, and meeting readers and audiences' characteristics of the time.

By the case of The Analects translated by Hongming Gu, he expresses frankly in his Preface that any has no knowledge of Chinese would be dissatisfied by James Legge's version after "reading repeatedly and patiently" from the standpoint of the third party. He describes "what Chinese knowledge and morality Doc. James Legge displays in his version must have produced some bizarre feeling as the clothes and appearance worn by Chinese in the sight of ordinary British people." It's clear that Gu completely considers the reading feelings of westerners to Legge's version, and studies his version under the pre-translation influence. For the motivation of altering the disadvantages of Legge's version, and the objective of "exerting efforts to deprive all the possible strangeness and bizarre style for British readers", Gu prepares to adopt "the same thinking way of an educated British people to express" and translate Confucian words [10]. It's much concrete to illustrate by Gu's "Li" from "有子曰：‘礼之用，和为贵。先王之道，斯为美.....’" to "A disciple of Confucius remarked, 'In the practice of art, what is valuable is natural spontaneity. According to the rules of art held by the ancient kings it was this quality in a work of art which constituted its excellence...'" [10] Gu elucidates it in annotation. Primarily, Legge thinks "Li" is not easily to be translated by other languages; it should be understood as "proper dictions, behaviors and so on" and translated into "the rules of propriety" in context.

However, Gu translates it into "art". He seeks the sense from the same characters from Chinese and Japanese and finds out B.H.Gibran states there's no natural expression for art in Japanese in his book *Things Japanese*. Then Gu lists all the meanings of "art", that is, "a work of art", "the practice of art" in literal meaning, "the principle of art as opposed to the principle of nature", "the strict principle of art" in liberal meaning, "artificial as opposed to natural" in reference meaning, and the system meaning of "art" is similar to "the idea of what is proper" for all the relationship in Legge's version. Gu analyzes the signified scope of "art" in target sense by listing all meanings in thinking course and introduces its applied collocation in three languages. He compares the Chinese and Japanese collocation, Chinese term artwork is for the operation of skills, mightily expressed by "cultural relic", while Japanese uses "Geisha" to express literal meaning "artiste". Just as Zhuang Zi uses "human" and "divine", "art" is for expressing "artificial" as opposed to something "natural". Therefore, "the principle of art, not taken by itself, but as opposed to the principle of nature", Chinese uses '文' to replace 'art', '质' to 'nature'. Goethe once put "Art is called Art, because it is not Nature" as an example, Chinese or Japanese quotes it as "文之所以谓之文为非质也". Chinese art critics also call "chemical engineering" as creative art, "commercial painter" as mimic art. Besides that, Gu completes Chinese term would like to name the mechanical art or practice as "artistry" [10]. Apparently, Gu has been qualified with excellent Chinese, Japanese and English basis, linguistics, literature and other knowledge accumulation before translation, He focuses on target language and recipients, considering the different pragmatic meanings and cultural connotations for target language application. Moreover, he takes the pre-translation effects, including accepting attitudes and understanding degree of recipients, into account, concludes and teases it generally, then comes to the translation course of the unit "Li".

2.2. For Source Language and Target Language

When it comes to the Chinese classics text analysis in the layer of source language, translators need to classify the source text genre (STG) into poem, sentimental and descriptive composition, singing verse, essay, drama, fiction, literary theory, discussion, memorial to emperor, stele script, miscellanies, eulogy, proverb, inscription and so on literature forms. At the same time, it should restrict the source text scope (STS) of source text into one or more target languages or cultures. To adopt written, archaic, formal or colloquial, modern and informal translation language is another essential aspect according to the source text language (STL). Besides that, the selection of vocabulary, phrase, sentence, paragraph and so on translation units (TU) should be examined closely then. Certainly, translators should also have meticulous, accurate and elaborate understanding (STU) to the total thinking of source writer or speaker, main idea of paragraph structure, the rhetorical meaning, semantic meaning, original meaning, extended meaning, reference meaning and so on

facets. Moreover, it still needs to have substantial translation preparation of applied translation strategies (TS), such as literal translation, liberal translation, domestication, foreignization, equivalent transformation, dynamic equivalent translation, semantic translation, communicative translation.

As coming to the text analysis of source language, it would be interlaced with the translation transformation of target language. Translators need to trace back to the same or similar signified in archaic text's social, historic, religious, ideological cultures and opinions as in source vocabulary, phrases, sentences, and paragraphs, contrasting semantic meaning, cultures, structure and so on aspects to seek for referential evidences, that is, history study of source text (HSST). After the synthesized thinking information by brains, it's necessary to search for translation equivalents or similar units, in order to compare and contrast bilingual vocabulary, phrases, sentences or paragraphs. That's useful to analyze and extract the optimal information, integrate information, transform information, transmit information, correct information, discuss and amend among translators and produce so on procedure to achieve initial target language. That composes the translation analysis process (TAP). Through the target language introduction (TLI) of translators and compilers to translation intention, thinking, and so on facets, translators could present annotation of source text, central thinking, interpretation of translation, explanation, notes and commentaries simultaneously. It could also form an independent part, target language exegesis (TLE), under each translation explanation entry. To add some explicit categorized key terms, classified summary, background knowledge and so on information would be beneficial for readers' comprehensive understanding in target language appendix (TLA). Refer to the target language publishing (TLP), it would have some other problems, such as later amendment, output, proofreading, printing, bookbinding, translators might have new round amendment for source understanding and target text. If it is the classic text interpreting of sentences or smaller units, here many procedures might be omitted.

Taking Legge's translation of "Tian Ming" as an example, "Confucius said, 'There are three things of which the superior man stands in awe. He stands in awe of the ordinances of Heaven. He stands in awe of great men. He stands in awe of the words of sages.'" [11] Its source text is "孔子曰：‘君子有三畏：畏天命，畏大人，畏圣人之言。小人不知天命而不畏也，狎大人，侮圣人之言。’" [11] Legge lucubrates the source text structure in Han Dynasty, writing time, writers, objectives, authenticity, comments of The Analects, the influence and authority of Confucius in China, the universal praise to Confucius, Confucian self-comment and his ideology summary, comments of Confucian disciples and followers in his preface. Legge analyzes it from his faithless and irreligious aspects, and generalizes the words of Confucius into different topics, including the exposition of *Shi Jing* and *Shu Jing*, the preservation to Li, teaching knowledge, ethics, devotional spirit, righteousness, and honesty. In his study on history of

source text, he thinks Confucius could not achieve the level of ancient sages and men of virtue, firstly for the decrees on God. He explains *Shi Jing* and *Shu Jing*'s "Di" or "Shang Di" is the existence with personality, who could be in charge of heaven and earth; meanwhile, also the creator of morality, who could grant a reward or implement punishment. Emperors govern whole countries by "Di", princes judge by him too, but Confucius likes to name it as "Tian" better. Secondly, Chinese have worshiped Shang Di since the ancient age, moreover, some other spiritual worship, such as some person and departed ancestors worship, of which are all treated by Confucius as a whole religious regime enthusiastically. Legge thinks it would rather say Confucius is suspicious of them than believing, for he frequently refers to "Tian" but not using the diction as ancient sages, hence, he has confused followers' knowledge to Shang Di with rational principles and natural rules. Legge finally summarizes "natural affection, the feeling of loyalty, and enlightened policy", may effectively build up and preserve a family and a state, it requires more to "maintain the love of truth", and to "make a lie, spoken or acted", would "be shrunk from with shame". Nevertheless, all of those are based on "the living recognition of a God of truth, and all the sanctions of revealed religion". Legge thinks Chinese have no such faith, but always cheating themselves and then others by kneeling down before Confucius as the wisest and meekest idol [11]. In the analysis and annotation of Legge to the source text of The Analects, the diction presents the feature of educational text, with formal colloquial English, ascribing "Tian Ming" the unit as attributive structure. He pays much more attention on the differences based on the similarities of the same signified quoted by Confucius and ancient sages, after prudent study on the referential and semantic meaning of "Shang Di" in the ancient books. Then he quotes Zhu Xi's words to illustrate "'Tian Ming' is the 'moral nature of man, conferred by Heaven", who is superior to other creatures and lays human under great responsibility to cherish and develop themselves. The phrase in some certain context could also displays "Tian" would have moral governance by punishment and blessing. Legge even completes "Da Ren" in the sentence, the one in the highness, who is wise with good virtue and good teaching as teacher and governor highly praised by "Tian". What's more, he categorizes "Tian" of Confucian words in the appendix. The process focuses on source language, and integrates interlaced study from source language to target language till produces "Tian Ming" comprehensively as "the ordinances of Heaven".

2.3. For Recipients

Seeing from the angle of recipients, target recipients' understanding (RU) to target translation are restricted by self-knowledge level, culture understanding level, social background, the range, depth, angles of understanding and so on aspects, which also confine translators. At the same time, target recipients would generate psychological refusing, accepting, absorbing or integrating translation thoughts, and behavioral rejecting, misreading, misunderstanding or

spreading translation after reading target text, which might influence translation publishing policy, namely, post-translation influence (POTI). The translation education, retranslation, adaptation, supplementary translation and so on more translation, translation study, and translation utilization, are conclusively named as translation application (TA) after target text transmission, which would co-act to the new round translation with post-translation influence from readers.

As for the latest full translation and annotation version from Guozhen Wu, the preface shows Wu translates mainly for overseas readers nowadays. In order to make the whole book readable, the version sets "simple translation" as criterion to amend the cultural estrangement of James Legge in 19th century. In considering of the evolution of English and transmitting Confucian ideology through Confucius, the friendly envoy of economic and cultural communication between China and other countries, the version should be retranslated by the chance of overseas readers learning The Analects in Confucius Institutes. Wu lists "the frequently-used vocabulary interpretation" to generalize and summarize 21 proper nouns and other difficult terms probably causing comprehensive barriers for recipients. In order to form tridimensional cognition by establishing contact between the version and Confucian life in recipients' minds, Wu provides with the "Introduction of Confucian Life" in English. For instance, in one example of Wu's, he translates "曾子曰：‘吾日三省吾身：为人谋而不忠乎？与朋友交而不信乎？传不习乎？’" [12] into "Zengzi said, 'I ask myself several times in my daily introspection: Am I not dedicated when handling affairs for others? Am I not faithful in association with friends? Have I not reviewed the lessons taught by the teacher?'" [12] He does not only translate but also interpret the original sentence by modern Chinese vernacular to help target readers understand source text clearly, moreover, he offers English notes of "Zeng Zi" and "Xing", introduces the central meaning of the sentence, other relevant content, some historical background and comments possible not clear to recipients. The whole version all adopts the above format and translation ways to present concisely and explicitly. Comparing with the extensive and redundant version by academism, recipients would not feel insipid and superficiality. After the first publishing, Wu deletes some English interpretation of difficult words in the source annotation on the second publishing book for he thinks that would not make too much troubles for Chinese readers, but remains the English translation for helping English readers comprehending the gist and historical background of the source text. His version mainly retranslates in the center of recipients with the plain and clear diction for easier digestion, which is a shortcut for recipients' study.

3. The Interaction among all Procedure Elements in English Translation for Chinese Classics

For the horizontal angle, translators would be firstly

influenced by pre-translation recipients' understanding, so increase some potential new knowledge. And for knowledge background with different translation motivations and intentions, translators would apply different translation ways by translation time to come to the next analysis of source language. While source language analysis needs to employ different expression by source text type, it should use various translation strategies and have profound perception of different text units in various translation scopes. Then it would come to logical relationship of target language level, original source text study of various translation units, micro-synthesis, comparison, analysis, integration, screening, transformation, renewing, and outputting in minds to present initial target text, furthermore, the later translation introduction, exegesis, appendix and publishing would affect target language after amendment to display translation width and depth. Recipients would produce different post-translation influence and application in diverse understanding levels, which could also be counteractive to the new round translation path.

For the single angle, when translating Chinese classics is translator-centered, source language, target language and recipients all point to translators, serving for translators, whose objectivity would be vulnerable under subjective impacts. The case is usually observed in some classics translation with some subjective-inclined translators influenced by politics, history, society and so on facets. When the classics text is source-text-centered, translators, target language and recipients all point to source language and serve for source language, the main role of translator would be overlooked or concealed. And target language usually employs domesticating strategy, which might make translation style dull and lengthy, not achieving the aesthetic criterion of target language. However, the recipients initially reading the version would not understand well for cultural disparity. It always appears in some first translation version of classics text for no more predecessors' references, mainly inclining to faithfulness, certainly, some historic books, code, scientific and technical literature and some special genre require higher faithfulness than others, translation must be source-text-centered primarily. When translation is target-centered, translators, source language, recipients all point to target language and serve for target language, translators might use dynamic equivalence strategy to satisfy the expression habits and features of target language and infuse into target environment, but not reflecting source content loyally to some extent, which is usually found in those with diverged culture and too much vagueness in source language. When the translation is recipient-centered, translators, source language, target language all point to recipients and serve for recipients, translators almost use foreignizing strategy. Source language would be presented with giant variation in target language for misunderstanding, different accepting cases and application deviation, more likely, it turns into translation creation, totally different form source language. It mostly appears in some abstract literature classics translation, such as Tang Poetry, Song Lyrics, and

Yuan Drama.

Certainly, for the multi-angle, translating classics could also be carried out in the center of two or more layers to play the core function simultaneously and have relevant relationship, which exerts effort to achieve the mutual balance among realizing translators' value, keeping faithfulness to the source language, integrating into the target language and recipients' appreciation. Translators might give consideration to regard target language and recipients as the center, that is, translators and source language all serve for target language and recipients, which could make some translation work more creative, typical and distinguished in target language. It could also treat translators, source language, and recipients as the center, that is, target language serves for the other three facets, which would produce the phenomenon with high faithfulness in strong domestication, but not reflecting aesthetic image of the target language perfectly. Translators might also consider the whole four facets at the same time, balancing them as cores all together when come to translating, however, the thinking path centered by multi-angle in the specific practice and study does not usually work in the same translation unit contemporarily, but interweaving wax and wane in the different translation units with relative complicated correlation.

4. Thinking Path Schema of English Translation for Chinese Classics and Introduction

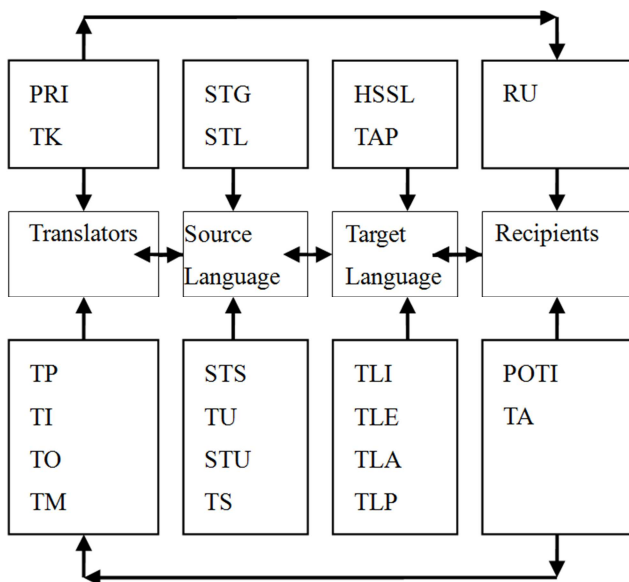

Figure 1. Thinking Path Schema of English Translation for Chinese Classics.

Synthesizing the parallel angle, from translators to source language, then target language and recipients, each section could be the single angle and center of translation process. And multi-section could also be the multi-angle and center of translation process in the interaction to form the general macro thinking path schema of English translation for

Chinese classics, as showing in figure 1. For each process element and connotation are explained in the above content logically, here it is omitted.

For those written translators, they would coincide or diversify translation strategy to some extent. In diversified strategies, the same translation unit might blend many strategies sometimes. The history study of source text mostly is dealing with those hardly translated words or phrases with unique Chinese cultures, history and customs, investigating and researching on their origination to seek for the proper translation motivation. When the source text unit is a word, it would have semantic variation in collocation or different context background; when the source text unit is a phrase, it might have semantic extension in context background, which needs to be translated in comprehensive but not single way. It's not absolute to amend target language during the translation publishing section, sometimes, for no more problems in translators' amendment, editing, proofreading, bookbinding, and printing, it's not necessary to re-amend target language.

For those interpreters, pre-translation influence, the accumulation of translation knowledge, translation analysis process, and post-translation influence have more impacts than other sections in the thinking path. Nevertheless, interpreting, especially the simultaneous interpreting is always finished in short period with diversified effects. Translation period, objective, source text genre, scope, history study of source text, translation text introduction, exegesis, appendix, and translation publishing might be all overlooked for lacking long-term study. Moreover, interpreters mostly translate classics in the unit of sentence, so interpreters' translation linguistic memory is basically centered on source language, target language or recipients, which classics translation version has direct impacts on interpreting output. Besides, consecutive interpreting has more thinking time to be influenced by translation strategies, target language output has no more relation with interpreters' translation theory inclination, but relevant to their short-term memory feedback.

For those computer-assisted and relying on machine translation, some computer translation applications would neglect the whole translation thinking path intensively, but directly present the prestigious translators' or internet translators' versions on the target output. It has extremely shrunk the time of searching, comparing and researching on the parallel target language, but for retranslation, adaptation and supplementary translation, the translation ways are just references and translators need to think through the above translation path orderly or stride over some sections according to the requirements.

5. Conclusion

To infer the prestigious translation versions of The Analects reversely, the conclusive summary, supplementary renewing, sublimation and illustration of the overall thinking path of English translation to Chinese classics are for

exploratory proposing the thinking path schema of English translation for Chinese classics. Its application in translation education is beneficial for systematically cultivating classics translators, training integral translation thought and building up translation team in universities effectively. In the translation comparative practice, translators could consider the path selectively in case of overgeneralization or leaving many important details. In the translation study, especially translation critics could treat various versions justly through the path schema, different translation output actually is closely bound up with translators' thinking path and inclined thinking angles.

Acknowledgements

The paper was supported in part by Jiangsu Educational and Scientific "13th Five-Year Plan" Annual Project in 2016 — The Empirical and Exploratory Study on Theory Application Schemas of Interpreting and Translating Courses in Chinese Universities (No. C-c/2016/01/41), and A Project Funded by the Flagship Major Development of Jiangsu Higher Education Institutions (PPZY2015A012).

References

- [1] Guoyue Zhao. On the Latest Trend of Chinese Translation Theory Studies --- National Translation Studies Strategic Forum (2014 Haikou). Nanjing: Translation Forum, vol. 1, 2015, pp.92.
- [2] Jiansong Jiang, Liyuan Peng. Cultural Context and the Translation of Chinese Classics: Reflections on a Research Topic. Beijing: Foreign Languages in China, vol. 2, 2006, pp.74.
- [3] Jing Yang. A Critical History of the English Translation of Chinese Confucian Classics in the 20th Century of the United States of America. Kaifeng: Henan University, 2014.
- [4] Jun Xu. On Translation. Nanjing: Yilin Press. 2014.
- [5] Hongyin Wang. Problems of Translating Chinese Classics and Solutions. Beijing: Chinese Culture Research, vol. 2, 2015, pp.66
- [6] Qiyi Liao. Contemporary Translation Studies in UK. Wuhan: Hubei Education Press, 2001.
- [7] Fenghua Li. Theoretical Basis on English Translation for Chinese Cultural Classics. 3rd International Conference on Education, Management, Arts, Economics and Social Science (ICEMAESS 2015). 2015.
- [8] Fenghua Li. Current Situation and Results on English Translation Research for Chinese Cultural Classics. Proceedings of 2015 3rd International Conference on Education, Management, Arts, Economics and Social Science (ICEMAESS 2015). 2015.
- [9] Junping Liu. A General History of Western Translation Theory. Wuchang: Wuhan University Press, 2009.
- [10] Hongming Gu. Collected Works of Hongming Gu. Haikou: Hainan Press, 1996.
- [11] James Legge. Confucius: Confucian Analects, The Great Learning and The Doctrine of the Mean. New York: Dover Publications, Inc. 2013.
- [12] Guozhen Wu. A New Annotated English Version of the Analects of Confucius. Fuzhou: Fujian Education Press, 2015.