

# Methods for Improving the Transient Operation of the Diesel Engine of Transportation Vehicles

Phan Van Quan<sup>1</sup>, Nguyen Van Nguyen<sup>2</sup>, Tran Anh Tuan<sup>3</sup>, Vo Trong Cang<sup>4</sup>

<sup>1</sup>Faculty of Naval Architecture and Offshore Engineering, Ho Chi Minh city University of Transport, Ho Chi Minh City, Vietnam

<sup>2</sup>Department of Marine Engineering, Maritime Technical College of Ho Chi Minh city, Ho Chi Minh City, Vietnam

<sup>3</sup>Faculty of Automotive, Tran Dai Nghia University, Ho Chi Minh City, Vietnam

<sup>4</sup>Faculty of Transportation Engineering, Ho Chi Minh City University of Technology, Ho Chi Minh City, Vietnam

## Email address:

phanquan@orientmarine.com.vn (P. V. Quan); vtcang@hcmut.edu.vn (V. T. Cang)

## To cite this article:

Phan Van Quan, Nguyen Van Nguyen, Tran Anh Tuan, Vo Trong Cang. Methods for Improving the Transient Operation of the Diesel Engine of Transportation Vehicles. *International Journal of Mechanical Engineering and Applications*. Special Issue: Transportation Engineering Technology. Vol. 3, No. 1-3, 2015, pp. 63-68. doi: 10.11648/j.ijmea.s.2015030103.20

**Abstract:** The transportation vehicle Diesel engines request the higher power with small dimensions for the suitable installation to carry the goods and passenger. They always work with changing the outside condition such as: the ways, the rivers, the sea and the ocean conditions. Therefore, the Diesel engine of the transportation vehicles will be working in the transient operation. In the transient operation condition, the Diesel engine will not be in up air for burning fuel or the Air/Fuel ratio always change. In the paper, we would like to research and introduce methods applying for improving the transient operation of the Diesel engine of transportation vehicles.

**Keywords:** Electronic Control Unit (ECU), Valve Variable Timing (VVT), Variable Geometry Turbocharger (VGT), Revolutions Per Minute (RPM)

## 1. Introduction

The exhaust gas turbine and air intake compressor (turbocharger) are installed in the Diesel engine of the transport vehicles for increasing the power of engine about 30% in compared with the case of the same size engines without the turbocharger. However, the engines always work with load changing condition and depend on the change of outside condition therefore the engine will frequently work in the transient operation. In this operation, the inertia moment of the engine and the turbocharger cause the decreasing of the intake air into the engine. This is consequently cause the fuel is burned incompletely in the cylinder; that the black smoke is blown out into the environment; that the power and the effect of the engine immediately decrease with increasing noise [5].

With the above disadvantages mentioned, for improving the transient operation of the Diesel engine of transportation vehicles, the process of intake air into the engine cylinder must be improved to ensure the best of A/F ratio and complete burning of fuel. Following the construction of the diesel engine and the turbocharger, there are many solutions for improving the transient operation of the Diesel engine,

such as:

- a. Methods affect on the inertia of diesel engine and turbocharger including:
  - Reduction of engine inertia;
  - Reduction of the inertia of turbocharger;
  - Selection of volume and configuration of the vent;
- b. Methods affect on the intake air process to the engines consisting of:
  - Effect on turbine;
  - Effect on air compressor;
  - Effect on diesel engine;
- c. Using of the external energy supporting for the intake air to the engine:
  - The air supercharger to engine;
  - Using of the hybrid turbocharger;
  - Using of the mechanical turbocharger.

## 2. Methods for Improving the Transient Operation of the Diesel Engine

### 2.1. Methods Affect on the Inertia of the Engine and the Turbocharger

#### 2.1.1. The using of Two Turbochargers Working in Parallel

To reduce the inertial moment of the turbocharger rotor, its weight is designed to be the smallest by using the lighter materials as titan, aluminum, ceramic...

For the V-type diesel engine, two smaller turbochargers will be used in parallel operation to replace the bigger one turbocharger (Figure 1) [3].

However, as the Turbochargers with the small inertia moment are used, it is easy to have the cases of the high loading and speeding conditions, which make the charged air's pressure is increased so high, as well as the engine and the turbo group will be in danger.



Figure 1. The diesel engine Man B&W 20V28/33D with two small turbochargers

To solve this problem, an automated waste – gate is installed on the exhaust pipe [4] (Figure 2).

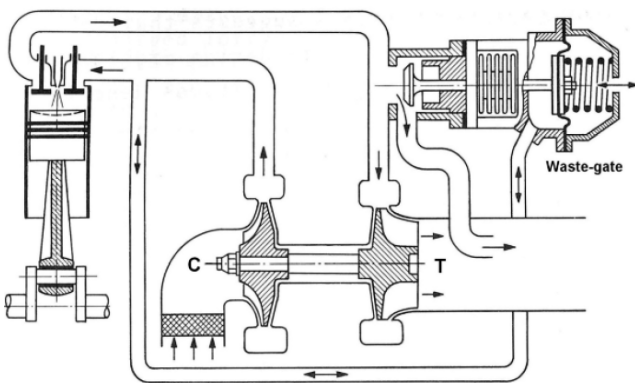

Figure 2. The using of the automated waste-gate

#### 2.1.2. The using of the Combination of Mechanical Charger and the Turbocharger

To support the intake air process, this method uses the charger combination. This method uses both mechanical and exhaust turbine chargers. The engine drives directly the turbo compressor and the rotation of the turbocompressor

is proportional to the speed of the engine(Figure 3)[3].

Disadvantage of this method is spendon part of engine power for driven the compressor. This power will increase very high cause to decrease engine power, therefore this method is low effect to using.

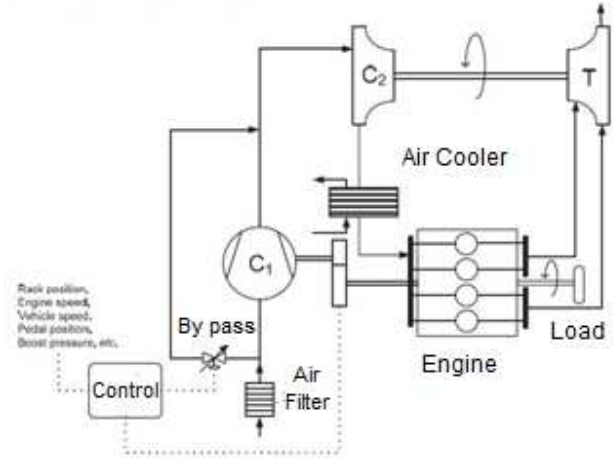

Figure 3. The Combined turbocharger

#### 2.1.3. The using of Two-Stage Turbine-Compressors in Serial Connection

The two-stage turbocharger in series is used for the truck engine or the marine engine with the high power. As the air pressure ratio is  $\geq 3$ , using the primary pressure will be difficult. To solve this problem, a solution is found as using the two-stage turbine compressor in series.

The model of the two-stage turbine compressor is described in Figure 4. In this diagram, two individual turbine compressors are used to connect in series. The after cooler is between the two compressors. It depends on each of the loading of the engine so the control systems will close and open all the system of valves to control the air pressure supplied into the engine. This makes the working space of the engine larger and the effect of the compressor better; however the system tends to be with the complex structure.

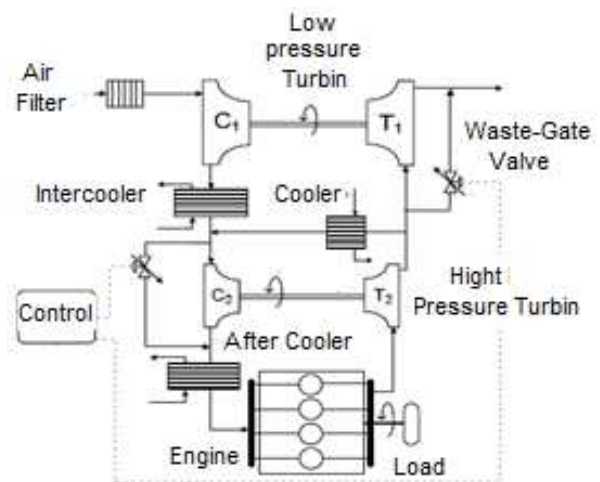

Figure 4. The using of two-stage Turbine compressors in serial connection

#### 2.1.4. The Parallel Using of Two Turbo Compressors

In the parallel turbo technology, two or more groups of Turbocharger with different sizes installed parallel with each other are used and mainly for the marine Diesel. If the turbine has smaller size, it will react rapidly with the charging of the working of the engine [4]. The installation and the structure of this turbocharger is described in Figure 5.

Under the light load and with the low speed, there is only

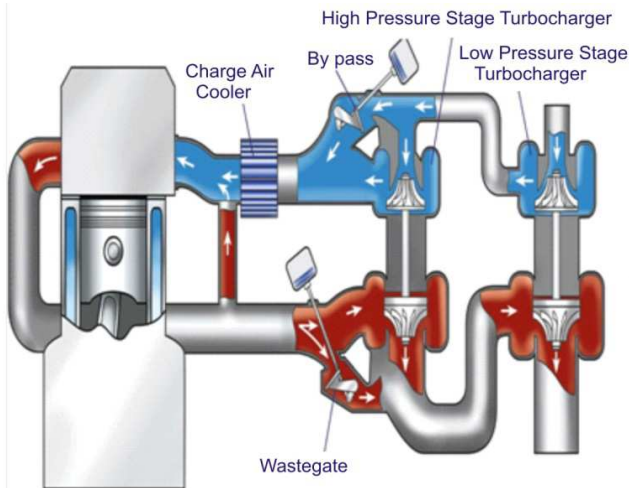

Figure 5. The using of two parallel Turbine compressors

#### 2.1.5. The using of Variable Geometry Turbocharger (VGT)

There is one kind of adjustable turbo charger with about 10 to 15 nozzle ring moving around the turbine blade (Figure 6). ECU will control by the stepper motor in order to revolve the adjustable nozzle ring at the same time, which makes the speed of rotor increasing. Since the acceleration makes the adjustable nozzle ring of the turbine increasing, the first pressure tends to be faster.

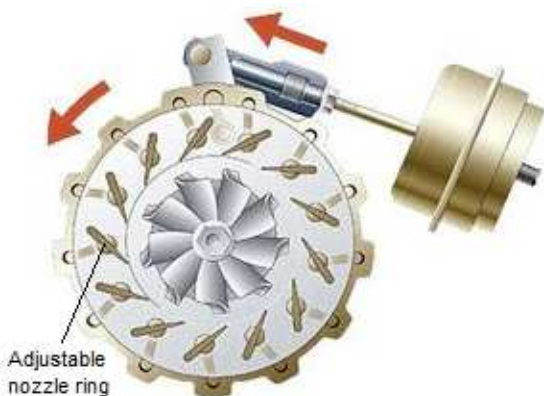

Figure 6. The using of VGT systems

As the engine works with the light loads and the low speed, ECU controls the stepper motor and revolves the adjustable nozzle ring of the turbine, which makes the nozzle ring open partly, reduces the prevention of the exhaust gas, and avoids the unnecessary supplying. As the loading is increased, the movable nozzle ring of the turbine will be open completely, the exhaust gas goes into the adjustable nozzle ring of the turbine then the speed and the power of the engine will be

increased. one group of turbocharger working. The intake air control valve is open tight to ensure the second turbine operates with the low speed; to avoid the high heat stress as the second turbine works unexpectedly in the case of the high increased load. The first turbine always works in all conditions of the engine. In the case of the high increased load it is requested the high intake air pressure, the second turbo will operate.

increased.

## 2.2. Methods Affect on the Intake Air Process to the Engines

### 2.2.1. Adding Air Intake to the Engines

It is used the additional compression air contained in the air bottle or the storage tank for injection into the compressor side [3] and supplying the additional compression air as well as more power into the turbocharger rotor at the same time. The solution is the increasing of the intake air into the engine rapidly and improve the quality of the transient process in the engine (Figure 7).

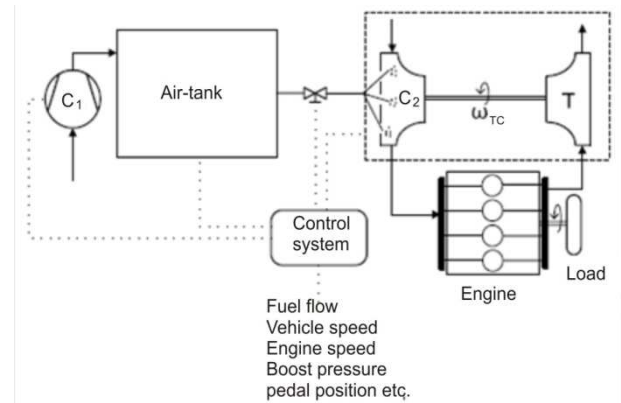

Figure 7. The air adding to the compressor

With the solution, the source of external air is used and controlled in accordance with the parameters of fuel, the engine speed, the high pressure turbo charging and the speed position in order to make the air bottle open and supply the additional air into the compressor side, which helps to improve the transient working process of the engine.

Like for supplying the air into the turbo compressor, the additional air intake pipe is putted directly into the vent of the engine.

### 2.2.2. The using of Common Rail System

This system, using the electric control unit, controls the amount of fuel, which is injected into the engine and maintained to be limited in accordance with the air intake pressure (Figure 8) [1].

It is requested to control fuel injection timing, period of injection and the amount of fuel to be injected into the engine. Today, the common rail system has been installed for the fuel pump and injector on diesel engine. The diesel engine makers design the new model of diesel installed an electrical control unit (ECU) with the multi variable parameters, such as: the

exhaust gas temperature, the RPM of the engine, the air intake pressure, the pressure of the combustion chamber ... and then the system will process control the injection timing, the period of injection and the amount of fuel to be injected into the engine.

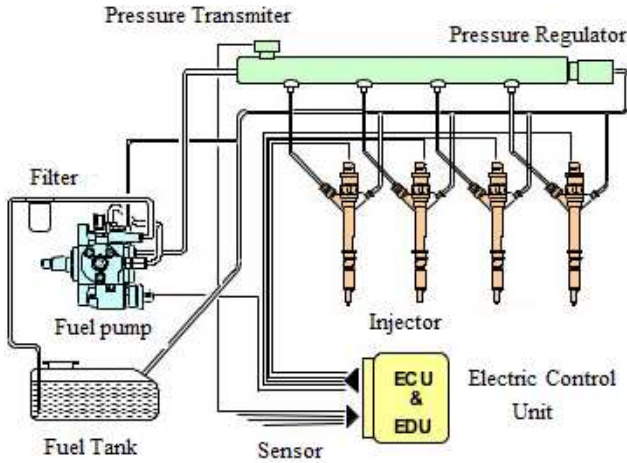

Figure 8. Common rail fuel injection with electric control unit

**2.2.3. The Controlling of the Injection Timing by VIT**

For the engine with the fuel pressure pump and injector, there is the optimal start injection angle to be adjusted so that the fuel is supplied and burned completely. The adjusted start injection angle is used only for continuous load of engine. In partially load and low speed of the engine, the start injection angle is not the same, which means that the differently delay ignition time is difference. This will affect the combustion quality [2].

To improve the quality of fuel burning process, the variable injection timing is found and so called as VIT. This structure will adjust the starting and the ending injection times in accordance with the speed of the engine, due to that the fuel is burned completely.

The fuel injection characteristic is performed in Figure 9. The structure of VIT in the engines of Man B&W Company is presented in Figure 10.

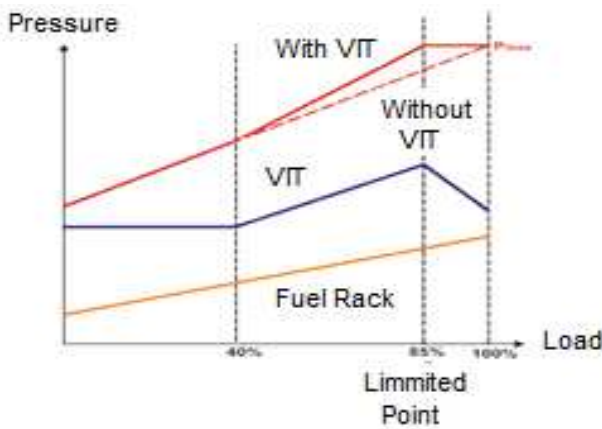

Figure 9. A characteristic of the fuel injection for the engines with VIT



Figure 10. The Injection Timing Regulation VIT in MAN B&W engines

**2.2.4. Variable Valve Timing Technology**

Apart from the above methods, there is another method for the improvement of the engine transient process in accordance with the principles affecting to the engine. In this method, the timing of the valve is changed in order to control the closing and opening times of the intake and exhaust valves in conformity with load levels of the engine [6].

In accordance with this method, the process from the opening to the closing of the valves will be changed in conformity with the shapes of the cams. The camshaft consists of two kinds of cams that are suitable for operation with the low speed and the high speed of the engine (Figure 11).

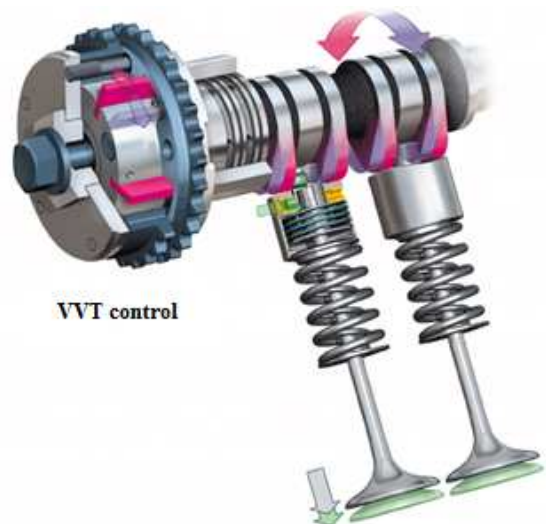

Figure 11. The Variable Valve Timing technology

Depending on the measured signal of the cooling water temperature, the air intake pressure and the engine speed, the VVT system will change the position of the cams, improve the transient operation of the engine, increase the efficiency

and reduce the fuel consumption. Therefore, this system is applied mostly by automobile manufacturers such as VVTL-I of Toyota, Vtec of Honda, Mivec of Mitsubishi, Valvetronic of BMW and VVEL of Nissan.

### 2.3. The using of the External Support Energy

#### 2.3.1. The using of the Addition Electric Motor Charger

The power gas turbine of the turbocharger depends on velocity, pressure and temperature of exhaust gas [3]

Under the engine's running with the light load or with the low speed, the power of the exhaust gas turbo is limited. Consequently, the charging air pressure is low and makes the reaction with the variation of the engine slow. Therefore, there is a technical solution using an electric motor for the connection of the turbine shaft. This helps to support the process of turbo charging and supply the additional energy for driving the air compressor instead of the case that the compressor is driven directly by the engine using the air intake charger as in the combination method (Figure 12).

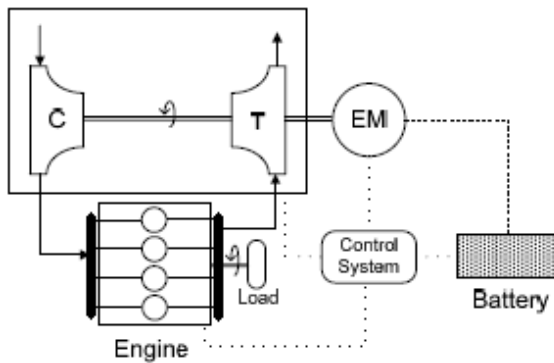

Figure 12. The Turbocharger supported by the electro-motor with the control system

#### 2.3.2. The using of the Hybrid Turbo Compressor

Apart from the method of using the external energy by having the electric motor for the support in increasing the rapid speed for the rotor of the turbine as the engine is working with the transient operation. With the current development of the control system and precise mechanical technology the Man B&W and Mitsubishi have experimented and produced a turbocharger group with bi-source of energy or so called as the hybrid turbocharger technology. The structural principal of the hybrid turbocharger system is presented in Figure 13.

According to the system structure, an electric motor is used and driven by the gas-exhaust turbocharger. In the case that the engine works in the transient operation, the motor will work as an electric motor and support in increasing the pressure of the turbocharger. In the case that the power in the turbocharger is supernumerary, the motor will work as an electric generator charging the batteries.

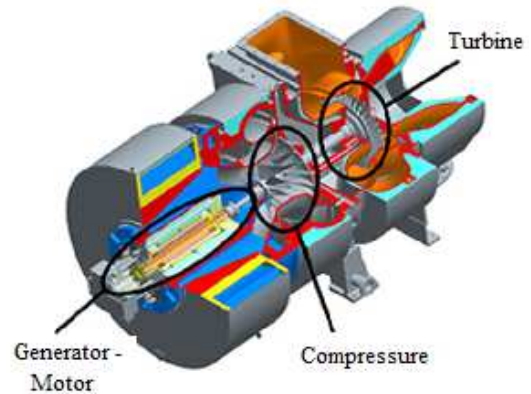

Figure 13. The System with the Hybrid Turbine-Compressor

## 3. Conclusions

Improving the quality of the transient operation of the diesel engines is increasingly interested to manufacturers. To ensure the transient operation there are many devices or subsystems for the support and the complement of the engine operation are used in the regimes of the engine.

Each method has its own advantages and disadvantages responding to the structure and the using of the engine. It needs to ensure that the engine running in the transient condition has the stable operation mode with the high efficiency and reduced fuel consumption.

## References

- [1] Bernard Challen, Rodica Baranescu. *Diesel Reference Book*, Butterworth-Heinemann. Linacre House, Jordan Hill, Oxford OX2 8DP 225 Wildwood Avenue, Woburn, MA 01801-2041, 1999
- [2] Kees Kuiken. *Diesel Engine I - for ship propulsion and power plants. From 0 to 100,000 kW*, Target Global Energy Training, 2008
- [3] Professor C.D Rakopoulos, Dr. EG. Giakoumis, *Diesel Engine Transient Operation*, Springer-Verlag London Ltd., 2009
- [4] Prof. Dr. Klaus Mollenhauer, Prof. Dr. Helmut Tschöcke. *HandBook of Diesel Engine*, Springer-Verlag Berlin Heidelberg, 2010
- [5] Phan Van Quan, H o Trung Phuoc. Surging turbocharger of the marine Diesel engines, *Vietnam Transportation Journal*, No 7, 2011
- [6] Variable valve timing, (available at <http://www.knowyourparts.com/technical-articles/vvt-variable-valve-timing>).

## Biography



**Phan Van QUAN** (1968, Da Nang)

He has received the Philosophy Doctor's Degree (PhD) in 2004 and Associate Professor in 2011.

Started academic staff of the Faculty of Marine engineering since 1995, his book "Governor for engine" was published in

2010; He has published the first paper "Applying digital control system for marine diesel engine", in Vietnam Transportation Journal, (ISSN 0866-7012) in 1999. His interest includes: The transient of diesel engine; Speed control system – Governor; Marine control system and the turbocharger for diesel engine.

Prof. Dr.Quan is the Dean of the Faculty of Naval Architecture and Offshore construction of the Ho Chi Minh city University of Transport.



**Nguyen Van NGUYEN** (1971, Viet Nam).

Master of Engineering (2008 –The governor of the diesel engine) the Viet Nam Maritime University. Field of study: Methods for improving the transient operation of marine diesel engines. Teaching at the Maritime Technical College of Ho Chi Minh city, Nguyen is a researcher for PhD degree at the

NhaTrang University, Vietnam.



**Vo Trong CANG** (1961, Saigon), PhD (2009) in Logistics and Operation Mgt.

Senior lecturer of the Faculty of Transportation Engineering at the Ho Chi Minh city University of Technology (HCMUT) - Vietnam National University of Ho Chi Minh city (VNU-HCM).

Work experience: shipbuilding, CG, R&D, educator. Former Head of the Naval Architecture and Marine Engineering Department of HCMUT. He has 20 publications in scientific papers and 10 presentations on international conferences. He has published 5 books and instructions in ship design and construction. He is an associate researcher at the Digital Control and Systems Engineering Key-Lab (DCSE-Lab) under the VNU-HCM.

(E-mail: [vtcang@hcmut.edu.vn](mailto:vtcang@hcmut.edu.vn))



**Tran Anh TUAN** (1986, Viet Nam), Master of Engineering (2014 - Ho Chi Minh City University of Technology and Education).

Research interests: Vehicle engineering; Automotive engine; Improving of efficiency, fuel consumption and emission in internal combustion engines, etc. Work experiences:

lecturer in the Engine Department, Faculty of Automotive, Tran Dai Nghia University, Ho Chi Minh city, Vietnam, since 2008.