

Multi-response ergonomic analysis of middle age group CNC machine operators

Imtiaz Ali Khan

Department of Mechanical Engineering, Aligarh Muslim University, Aligarh, India

Email address:

fayaqnoor@yahoo.co.in

To cite this article:

Imtiaz Ali Khan. Multi-Response Ergonomic Analysis of Middle Age Group CNC Machine Operators. *International Journal of Science, Technology and Society*. Vol. 2, No. 5, 2014, pp. 133-151. doi: 10.11648/j.ijsts.20140205.17

Abstract: This work is aimed on exploiting the performance in a human-CNC machine interface (HCMI) environment. Here load cell based developed system is capable of measuring cognitive and motor action responses simultaneously. Performance measurement system designed may be replicated for other fields where systems are operated through control panels and also where responses of mentally retarded human-beings (or human beings with symptoms of Alzheimer disease) are to be observed and evaluated. Following main conclusions are drawn: (1) Optimum multi-performance characteristics for middle age operators are $A_1B_3C_3$ (i.e. CNC machine panel height of 90 cm, panel angle of 90 degrees and working distance of 30 cm), (2) Percentage contributions of working distance, CNC machine panel angle and panel height are 55.93, 8.13 and 5.93, respectively and (3) An improvement of 41.12% in the multi-performance characteristics was achieved. This work has achieved a reasonable degree of validity through performing confirmation test. *Practitioner Summary:* The findings of this work are directly applicable to the practical field to improve the design of a CNC-machines system. This work suggests that those responsible for the functioning and operation of CNC machine workstations would have to redesign the system to reduce musculoskeletal injuries and other related problems of middle age male operators. Results presented in this paper can be quite useful for future system designers. It is emphasized that applying ergonomic principles to the design of CNC machines and interfaces can not only help to enhance machine performance and productivity, but can also enable the human operator to feel comfortable and secure. As most companies have acquired Automated Manufacturing Technology in recent years to be competitive, ergonomic and safety considerations are of the utmost importance in the design phase.

Keywords: Multi-Performance, Search Time, Motor Action Time, Applied Force, Load Cell

1. Introduction

This study is all about understanding how the anthropometric factors affect performance in a human-CNC machine interface environment. Historical evidences suggest that many of the injuries in manufacturing are musculoskeletal disorders caused by cumulative trauma. These injuries that result from cumulative wear and tear are called cumulative trauma disorders (CTDs). Back injuries, tendinitis and carpal tunnel syndrome are some examples of common CTDs. Work place risk factors for CTDs include repetitive motions, high forces, awkward postures and vibration exposure. Work related musculoskeletal disorders (WMSDs) remain a widespread and growing issue of concern in automated industries. It is estimated that over five million workers sustain overextension injuries per

year. Through ergonomic intervention, workplaces can be designed so that workers do not have to overextend themselves and the manufacturing industry could save billions in worker's compensation. Manufacturing companies once thought that there was a bottom-line trade-off between safety and efficiency. Now they embrace ergonomics because they have learned that designing a safe work environment can also result in greater efficiency and productivity. Recently, U.S. laws requiring a safe work environment have stimulated great interest in Ergonomics- from ergonomic furniture to ergonomic training. But it is in the design of the workplace as a whole where the greatest impact can be seen for both safety and efficiency. The easier it is to do a job, the more likely it is to see gains in productivity due to greater efficiency. The success of automated industries is based on the ergonomic design of

CNC machines and their interfaces.

Workstation's ergonomic design is dependent on considering the nature of tasks to be completed, the preferred posture of the operator and the dynamics of the surrounding environment (King and Fries, 2009). The design of the workstation needs to take into account the adjustability of the working platform, clearances under work surface, CNC machine panel and display support surfaces. The effectiveness with which operators perform their tasks at consoles or instrument panels depends in part on how well the equipment is designed to minimize parallax in viewing displays, allow ready manipulation of controls and provide adequate space and support for the operator. In the past, studies were conducted to investigate physical impairments caused to the operators due to various factors related to machining operation. Discomfort might be used as a measure for quantifying postural stresses (Kee and Lee, 2012). *Working posture* has been considered by many researchers as a focus on human performance (Choi et al., 2010; Dartt et al., 2009; Hansson et al., 2010; Lin et al., 2010 and Straker et al., 2009).

Imtiaz (2012), Imtiaz and Asghar (2011) and Imtiaz and Asghar (2010) researches evaluated the effect of working postures on human performance in a computer numerically controlled-electro discharge machine (CNC-EDM) environment. Assessments of the performance indicated a significant effect of levels of angle of abduction and viewing angle. To eliminate discomfort and reduce injuries as far as musculoskeletal and other related problems are concerned, findings of these researches suggested that CNC-EDM system should be re-designed so as to achieve, a 45 degree angle of abduction and a 21 degree viewing angle. Dartt et al. (2009) assessed upper limb postures of manufacturing workers using multimedia video task analysis (MVTA). The study demonstrated fair and good results in terms of postures reliability. Estimation of muscle activation based on electromyography (EMG) is believed to be the major source of uncertainty within the EMG driven model (Koo and Mak, 2005). It is noticed that brain-machine interfaces (BMI) have become a promising technology that can aid paralyzed individuals (Kim et al., 2009). It is observed that for computer numeric control (CNC) workers, repetitions and duration contributed more to the total effort than the postures, movements and forces (Vieira and Kumar, 2007). The study assessed perceived workload using discomfort ratings and visual analogue scale (VAS). *Through present study, a more realistic approach has been proposed for measuring human performance.* Serna et al. (2007) suggested that an executive mechanism should be introduced in the modelling of behaviors associated to people with cognitive deficits.

With the accelerated pace of installation of computerized machine tools and use of human machine interaction systems, the role of ergonomists in automated industries have become crucial. The ergonomists possesses not only behavioral but also technological skills and knowledge, which is a requirement for better design of human machine interaction environment. In future industries, ergonomists

will be involved for the development of effective research methodologies which could enhance significantly the productivity, product quality, quality of working life and standard of living (Imtiaz and Saraswat, 2009).

Slowing of motor performance in human aging is a well demonstrated clinical observation, both studied with simple and complex motor tasks (Jimenez-Jimenez et al., 2011; Ruff and Parker, 1993 and Shimoyama et al., 1990). Finger tapping (FT) frequency lowers with advancing age (Cousins et al., 1998; Elias et al., 1993 and Hermsdorfer et al., 1999). Aging seems to influence the performance of simple or complex reaction time tasks, including visual reaction time, being the response times longer in elderly people (Chen et al., 1994; Nissen and Corkin, 1985 and Pelosi and Blumhardt, 1999).

Behavioral performance in older adults is often characterized by normal error rates but longer response latencies compared to younger adults. The slowing of reaction times might reflect a compensatory strategy to avoid errors and might be associated with performance monitoring alterations. Endrass et al. (2012) investigated whether the ability to compensate for potential deficits influences age-related differences in performance monitoring. The study used a modified flanker task with either accuracy or speed instruction. The finding indicated reliable differences between conditions: accuracy, reaction times and error-related negativities were reduced in the speed compared with the accuracy condition. Also, older adults showed smaller error-related negativities compared with younger adults and the reduction was more pronounced in the speed condition. Further, the study concluded that similar-sized error-related and correct-related negativities were found in older adults. The results indicate that performance monitoring deficits in older adults are related to deficits in behavioral performance, at least if they are forced to respond quickly.

Research on age-related cognitive change traditionally focuses on either development or aging, where development ends with adulthood and aging begins around 55 years (Germine et al., 2011). The said approach ignores age-related changes during the 35 years in between, implying that this period is uninformative. Germine et al. (2011) investigated face recognition as an ability that may mature late relative to other abilities. The study using data from over sixty thousand participants, traced the ability to learn new faces from pre-adolescence through middle age. In three separate experiments, the finding show that faces learning ability improves until just after age 30- even though other putatively related abilities (inverted face recognition and name recognition) stop showing age-related improvements years earlier. The study data provide the behavioral evidence for late maturation of face processing and dissociation of face recognition from other abilities over time demonstrates that studies on adult age development can provide insight into the organization and development of cognitive systems.

Multiple causes contribute to the prolonged reaction-

times (RT) observed in elderly persons (Bautmans et al., 2011). The involvement of antagonist muscle co-activation remains unclear. Bautmans et al. (2011) studied Mm. Biceps and Triceps Brachii activation in 64 apparently healthy elderly (80 ± 6 years) and 60 young (26 ± 3 years) subjects, during a simple RT-test (moving a finger using standardized elbow-extension from one push button to another following a visual stimulus). RT was divided in pre-movement-time (PMT, time for stimulus processing) and movement-time (MT, time for motor response completion). The study indicates that RT performance was significantly worse in elderly compared to young; the slowing was more pronounced for movement time than pre-movement time. Elderly subjects showed significantly higher antagonist muscle co-activation during the pre-movement time phase, which was significantly related to worse movement and reaction times ($p < 0.01$). Also, during movement time phase, antagonist muscle co-activation was similar for both age groups. The study concluded that increased antagonist muscle co-activation in elderly persons occur in an early phase, already before the start of the movement. The findings provide further understanding of the underlying mechanisms of age-related slowing of human motor performance.

Chung et al. (2010) investigated the effect of age and two keypad types (physical keypad and touch screen) on the usability of numeric entry tasks. Twenty four subjects (12 young adults 23-33 years old and 12 older adults 65-76 years old) performed three types of entry tasks. Chung et al. (2010) noticed that the mean entry time per unit stroke of the young adults was significantly smaller than that of the older adults. The older adults had significantly different mean entry times per unit stroke on the two keypad types. Also, the error rates between young and old adults were significantly different for the touch screen keypad. The subjective ratings showed that the participants preferred the touch-screen keypad to the physical keypad. The results of the study showed that the older adults preferred the touch-screen keypad and could operate more quickly, and that tactile feedback is needed for the touch-screen keypad to increase input accuracy. *The study suggests that the results can be applied when designing different information technology products to input numbers using one hand.*

The use of computer controlled devices is constantly increasing. At the same time the population of the industrialized world is aging. Lindberg et al. (2006) investigated the speed with which users of different ages can find a specific computer icon from a group of others. The results show that *search performance* slows with age. However, individual variability in search performance was very high within all age groups. The study suggests that icon used in graphical user interfaces should be at least about 0.7 cm at a viewing distance of 40 cm, for the majority of users to be able to perform their computerized tasks with relative ease. Also, the study concluded that the inter-icon spacing should be moderate, preferably about the same as the icon size and ideally user interfaces should be

adaptable to individual user needs and preferences.

Although connections between cognitive deficits and age-associated brain differences have been elucidated, relationships with motor performance are less understood. Seidler et al. (2010) review age-related brain differences and motor deficits in older adults in addition to cognition-action theories. Age related atrophy of the motor cortical regions and corpus callosum may precipitate or coincide with motor declines such as balance and gait deficits, coordination deficits and movement slowing. The study concluded that in general, older adults exhibit involvement of more widespread brain regions for motor control than young adults.

Goldhammer et al. (2010) investigates the effects of intelligence, perceptual speed and age on intraindividual growth in attentional speed and attentional accuracy over the course of a 6-minute testing session. The study concluded that the intelligence was not associated with the ability to learn to perform the attention task quickly and accurately. Also, age differences were mainly related to baseline performance. Results indicate that the concurrent performance aspects, speed and accuracy, are distinct in the shape of growth. The global-speed and the specific-gain/loss hypotheses have been dominant theoretical frameworks in the literature on cognitive development and aging (Span et al., 2004). Few attempts have been made to explicitly assess the predictive power of the two frameworks against each other. Span et al. (2004) evaluated the extent to which age changes in performance in executive function tasks (involving response selection, response suppression, working memory and adaptive control) depend on age-related changes in global information processing speed. The study used sample consisted of children, adolescents, adults and seniors. The analysis revealed a mixed pattern of results. Controlling for global speed removed the child vs. adult differences in the speed of responding on the executive function tasks but the senior vs. adult differences remained. The study suggest that the effects of advancing age on the speed of responding are mediated by a global mechanism during childhood but during senescence the efficiency of executive functioning seems particularly vulnerable to the effects of age.

The population of the developed countries is becoming older while computer use is affecting increasingly wide aspect of life (Hawthorn, 2000). It is increasingly important that interface designs make software accessible to older adults. The study noticed that there is almost no research on what makes an interface usable for older adults. Hawthorn (2000) reviews the findings on the effects of age on relevant abilities and uses this information to provide suggestions to consider when designing interfaces for older users. *The study concludes with indications of the needed research in the area of interface design for older users.* Kang and Yoon (2008) observed the behavior of younger adults (20-29 years old) and middle-aged adults (46-59 years old) interacting with complicated electronic devices. The study examined various aspects of interaction

behaviors in terms of performance, strategies, error consequences, physical operation methods and workload. The analysis of age-related differences included differences in background knowledge. The results revealed that differences in age meaningfully affected the observed error frequency, the number of interaction steps, the rigidity of exploration, the success of physical operation methods and subjective perception of temporal demand and performance. In contrast, trial-and-error behavior and frustration levels were influenced by background knowledge rather than age.

The literature review indicates the need of separate interface designs for various age group individuals. It is also observed that the cognitive and motor performances of peoples vary with the age. Hence there is a need to take up more studies in order to dig deeply into the insight of the phenomena of human aging. However, further research is needed in manufacturing environment, to draw guidelines for the HCMI designers as to what level of anthropometric parameters will be really required to enhance the middle age operator performance. It is noticed that almost all researchers have strongly stressed on musculoskeletal disorders as the major source for human performance decrement. The present study considers the impact on performance in a human-CNC machine interface (HCMI) environment. Three response variables are selected for this work. First the search time, second the motor action time and third the applied force. Anthropometric factors in the present study are incorporated in terms of variability considered in CNC machine working environment. Keeping in view the above research work with respect to musculoskeletal disorders and anthropometric factors, three factors are selected for this work. First the CNC machine panel height, second the panel angle and third the working distance. The domain needs to enrich more for the benefit of the researchers and practitioners.

2. Methods

2.1. Problem Statement

As evident from preceding discussion, the effects of anthropometric considerations like machine panel height, panel angle and working distance on human performance particularly in the context of human-CNC machine interface (HCMI) are still not fully understood and thus, there exists a wide scope to investigate these effects. Accordingly, the problem for the present work was formulated.

There has been a rapid growth in the use of CNC machines. These machines have entered virtually every area of our life and work environments. With the CNC machine applications getting more widespread at the global level, the musculoskeletal problems associated with these machines have also been generating more concern. The automated technologies are getting much more popular day by day. However, the pace of research in the field of human-CNC machine interaction environment has been

rather slow in comparison to the growth rate of CNC machines not only in developed nations but also in developing countries like India. Human problems associated with the HCMI environment constitute one of the major research areas determining the extent and rate of success within the framework of effective and fruitful use of modern day's automated technologies. There remains a dire need of catering to the demands of designers, manufacturers, purchasers and users regarding how automated machine systems could be made more useful, easier, faster, efficient and compatible for operation, from ergonomics point of view. The literature surveyed indicated that previous researchers by and large, have been mainly emphasizing the need to design and develop varieties of automated machine systems.

In the recent era of highly competitive business environment, that is automated technology based, ergonomist cannot afford to remain ignorant of what is happening all around. The exponential growth in the use of CNC machines has brought many subtle issues/problems pertaining to their effective utilization from human efficiency and comfort view points. These problems get further aggravated when automated technology systems are used excessively in the kind of environments that are not conducive to their users. *In this background, the study put forth in the present work was designed to provide answers to some of the basic issues related to the use of CNC machine tools. The experiment was planned to investigate human performance on CNC machine tools under the impact of machine panel height, panel angle and working distance. Present study investigated the effects of middle 32-36 years age group male operator's performance on CNC machine tool.*

2.2. Experimental Design

In the study undertaken, human performances were measured in terms of search time, motor action time and applied force on the CNC machine panel keys. The search time, motor action time and applied force features were selected in the light of previous researches (Chen and Chiang, 2011; Bedny and Karwowski, 2006; Layer et al., 2009; Bothell, 2004 and Bergmann et al., 2011). Before the actual experimental work, a pilot study was conducted to determine the discrete levels of the three HCMI parameters that could help to operate a CNC machine tool, efficiently and comfortably. The factors and their levels selected for experimental investigations are described as follows. Three variables i.e. CNC machine panel height (Parameter A) at three levels "90 cm", "110 cm", and "130 cm" (Sanders and McCormick, 1992), CNC machine panel angle (Parameter B) at three levels "30 degrees", "60 degrees" and "90 degrees" and working distance (Parameter C) at three levels "10 cm", "20 cm" and "30 cm" (Chikhaoui and Pigot, 2010), were present in the study. The HCMI parameters/ design factors with their values on different levels are listed in Table 1.

Table 1. Variable levels used in the experimentation

Identifier	Factor	Unit	Level 1	Level 2	Level 3
A	CNC machine panel height	cm	90	110	130
B	CNC machine panel angle	degrees	30	60	90
C	Working distance	cm	10	20	30

The experiments were conducted based on *Taguchi's experimental design* for which an *appropriate orthogonal array (OA)* was selected. To select an orthogonal array for the experiments, the total degrees of freedom (df) are computed first. For example, a *three level* design parameter counts for *two* degrees of freedom. The degrees of freedom associated with the *interaction* between two design parameters are given by the *product* of the degrees of freedom of the two concerned design parameters. Therefore, in the present study, there are *eighteen* ($2+2+2+4+4+4$) degrees of freedom owing to there being, three HCMI design parameters (A, B, and C) with their corresponding three levels and three, two-way interactions A.B, A.C, and B.C. Once the required degrees of freedom are known, the next step is to select an appropriate orthogonal array to fit the specific task. Basically, the degrees of freedom for the orthogonal array should be greater than or at least equal to those for the design parameters (Goel et al., 2011). In this study, an L_{27} orthogonal array with 27 rows (corresponding to the number of experiments) was chosen for the investigations. The L_{27} (3^{13}) is an OA of 27 distinct rows and provide 26 degrees of freedom for studying different effects. This design matrix can be used to examine a maximum of $26/2 = 13$ two-df effects. Thus, the L_{27} can be used to accommodate a full 3^3 factorial design. The three parameters (A, B, and C) and three, two-way interactions (AxB, AxC, and BxC) will need 18 degrees of freedom and will occupy $18/2 = 9$ of the 13 columns of an L_{27} OA. The remaining four columns of the L_{27} OA are treated as dummy parameters.

Search time, motor action time and applied force were selected as response variables to evaluate the CNC machine operator's performance. A full factorial design (based on L_{27} orthogonal array) of experiments consisting of 27 (3^3) experiments was used to collect data for human performance in terms of search time, motor action time and applied force. The collected data were analyzed using grey relational analysis and analysis of variance (ANOVA) and F-test. These methods are described below:

2.2.1. Grey Relational Analysis

Grey relational grade is an index which represents multiple performance characteristics. It basically shows relations among the series of experimental results. The determination of grey relational grade requires pre-processing of the experimental data in order to transfer the original sequence to a comparable sequence. In grey relational analysis, the grey relational grade is used to show the relationship among the sequences. If the two sequences are identical, then the value of grey relational grade is equal to '1'. The grey relational grade also indicates the degree of

influence that the comparability sequence could exert over the reference sequence. Therefore, if a particular comparability sequence is more important than the other comparability sequence to the reference sequence, then the grey relational grade for that comparability sequence and reference sequence will be higher than other grey relational grades (Goel et al., 2011, Yang et al., 2006). In this work, the importance of both the comparability sequence and reference sequence is treated as equal.

2.2.2. Analysis of Variance (ANOVA) and F-Test

The purpose of ANOVA and F-test is to find which individual factors and interactions among them are significant for a particular performance characteristic. This statistical analysis is based on the variance, the degree of freedom, the sum of squares, the mean square, the F-ratio, the P-value and the percentage of contribution to the total variation (Goel et al., 2011, Layer et al., 2009). The detailed procedure for calculating parameters pertaining to ANOVA is described in (Samant et al., 2008). In this work ANOVA, interaction effect analysis and adequacy tests of various models were carried out using the Design Expert Software (Design Expert Software, 2012).

2.3. Subjects

A pool of 27 potential subjects was selected for the present work. This pool included middle age males ranging from 32 years to 36 years. The selected subjects were employees of the Aligarh Muslim University (AMU), Aligarh, India. A self-designed questionnaire was used to select the subjects. Out of the 120 questionnaires distributed among employees, 98 responded, out of which 27 middle age males were selected on the basis of well-defined anthropometric characteristics. The selected subjects also expressed their willingness to participate in the present study. No subject participated in more than one experiment.

2.4. Stimuli and the Experimental Task

Stimuli material was available to the subjects in the form of colored light emitting diodes (LEDs) fixed on an adjustable height display board. The colors used for visual stimuli were red, blue, yellow, white and green. These colors for visual stimuli were selected because existing CNC machines panels are using similar colors keys. So far as the availability of visual stimuli during the task is concerned, the LEDs 'on' and 'off' positions was controlled by the experimenter. The LEDs were connected to one of the channels (Channel-2) of an oscilloscope through a switchboard. An indigenously designed CNC machine

panel and working platform were used for all the studies. The panel was joined with 'load cells' (piezo-electric sensors), and the assembly was fixed on an adjustable 'height' and 'angle' platform (Sanders and McCormick, 1992). The variable working distance (Chikhaoui and Pigot, 2010) was incorporated with the help of colored strips pasted on the ground in front of assembled platform. The machine panel had two lead connections. First was with one of the channels (Channel-1) of the oscilloscope and the second, with the visual display unit (VDU) monitor through central processing unit (CPU). During the experimentation, subjects stand according to the selected HCMI parameters combination in front of the working platform (Maldonado-Macias et al., 2009) with index finger of the right hand placed (for recording search time) on the CNC machine panel 15 centimeters away (Chikhaoui and Pigot, 2010) from the panel keys (used for recording motor action time and applied force). Left hand of the subjects remained free along the side. The subjects were required to respond to the visual signal (in the form of particular color LED on-position for a short period), provided by the experimenter through switchboard. The signal at the moment of 'LED-ON' is recorded through the oscilloscope. Subjects were asked to search, without lifting right hand index finger, the CNC machine panel where the key, similar to first alphabet of the activated color stimuli exists (i.e. for Green color the first alphabet is 'G'). As soon as the required 'key' is 'searched', the subject lifts the index finger and presses the key. The signal at the moment of 'finger-lift' is recorded through the oscilloscope. The time difference in milliseconds, between visual-stimuli and finger-lift is saved as the 'search time' (cognitive time). To ensure the correct execution of the task (matching 'key search and press' on the basis of supplied visual signal), a software in C++ language was developed, which also helped to get 'zero error' experimental results. The software was loaded on the computer system connected to self-designed CNC machine panel assembly. As a particular alphabet (out of five R, B, Y, W and G only) key is pressed (on the basis of visual signal) on the machine panel, the loaded software displays a full VDU screen image (square shape) of the color whose first alphabet is pressed (i.e. if the subject presses 'R', the software displays a full VDU screen square 'RED' shaded image). This ultimately ensures the correct execution of the task. If a task was executed incorrectly, the task was repeated in random order to get additional data. The software does not display any image if a key other than one for the five above mentioned alphabets, is pressed. Two more signals at the moment of 'searched key pressing' were recorded, first on x-axis of the oscilloscope and the second on y-axis. Through x-axis, the time difference in milliseconds between 'finger-lift' and 'searched key press' moments was saved as 'motor action time'. When the searched key was pressed, the 'applied force' on the panel key in millivolts was recorded through the y-axis of the oscilloscope. Each subject executes the same task against five (Red, Blue, Yellow, White and Green) randomly

supplied visual stimuli. The experiment was uniform for all participants. Finally, the average of, five performances in terms of 'search time', 'motor action time' and 'applied force', was recorded for analysis. For experimental validation, movie of each subject was also recorded through a video camera (SONY Digital Handycam; HDR-XR500: 12 mega pixels). The video camera was used to record and take photos of the subject to identify stressful body postures during the CNC machine operation.

2.5. Experimental Set-Up

In this research a CNC machine panel was simulated using a conventional computer keyboard that was fixed to an adjustable platform with load cells (piezo-electric sensors) linked to specific keys. The height and angle of the platform were adjustable and the ranges of these controllable parameters in the experiment are given in the following paragraphs.

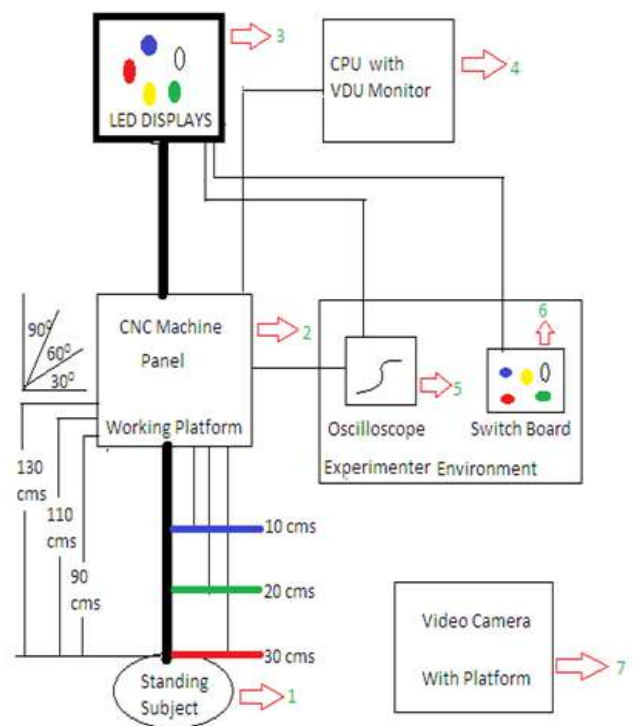

Figure 1. Schematic diagram of the experimental set-up employed in the experimental investigations undertaken in the present work

Human performance was measured in terms of search time, motor action time and applied force on the machine panel keys. All experiments were performed in a simulated environment chamber of 5.2 m x 4.4 m x 2.9 m size, specifically developed within the premises of the Department of Mechanical Engineering, AMU, Aligarh, India. The temperature of the experiment chamber (Sanders and McCormick, 1992) was approximately 23 ± 2 degree Celsius measured through wall temperature indicator (model: me DTI 4001). Reflection of the light from windows and door was eliminated through proper covering. When the chamber was closed, the cubicle got acoustically

sealed from the outside environment. The illumination level throughout all the experimental sessions (OSHA, 2011, Sanders and McCormick, 1992) was maintained at 590 ± 10 lux. This level of luminance was monitored through a digital lux meter (model: LT Lutron LX-101). The relative humidity level of the experiment chamber (Sanders and McCormick, 1992) was approximately 77 ± 3 percent measured through hair hygrometer (model: Ekbote HAIR Hygrometer). Sound level throughout all the experimental sessions (OSHA, 2011, Sanders and McCormick, 1992) was approximately 52 ± 3 dBA measured through sound level meter (model: LT Lutron SL-4001). Measuring tape, digital vernier caliper and weighing machine were used to measure various anthropometric characteristics of the subjects. The search time, motor action time, and applied force were measured through 2-Channel Oscilloscope (model: DS 1062 C; make: Rigol Digital Oscilloscope Ultrazoom; specification: 60 MHz 400 MSa/s). The positions of the indigenously designed CNC machine panel, subject and other peripheral devices were maintained as portrayed in the schematic diagram in Figure 1.

As shown in the Figures 1 and 2, the standing subject (item 1 of Figure 1) in front of CNC machine panel can maintain any working distance (10/20/30 cm) according to colored strips.

The working platform (item 2 of Figure 1) can be adjusted at any (90/110/130 cm or else) height through adjustable screw as depicted in Figure 3.



Figure 2. Working distances shown with colored strips



Figure 3. CNC machine panel height adjustment system

The CNC machine panel (item 2 of Figure 1) can also be adjusted at any (30/60/90 degrees or else) angle through adjustable mechanism as shown in Figure 4.



Figure 4. CNC machine panel angle adjustment mechanism

The item 3 of the Figure 1 provides colored visual stimuli. The provision of variable height visual signal with colored LED board is shown in Figure 5.



Figure 5. Variable height colored LEDs board



Figure 6. A full VDU screen square with green color in response to supplied green visual stimuli

The item 4 of Figure 1 indicates an environment where a CPU and VDU monitor was stationed for ensuring correct execution of the experimental task. Figure 6 shows a CPU and VDU monitor arrangement displaying green square image when subject on the basis of activated green LED visual signal, presses alphabet 'G' on the CNC machine panel.

Items 5 and 6 of Figure 1 are showing experimenter environment with a 2-Channel oscilloscope for recording human performance and a switch board for providing visual stimuli, respectively. The Figure 7 depicts the arrangements of oscilloscope and switch board.

The item 7 of Figure 1 shows location where from the

movie of the subjects performing the task was shot. Figure 8 indicates the position where a SONY Digital Handycam video camera was stationed.

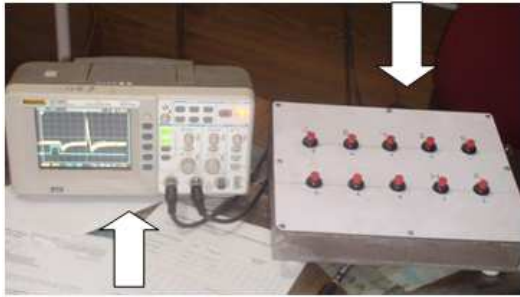

Figure 7. Oscilloscope and switch board positions



Figure 8. Showing stand where camera was fixed

Figure 9 shows a subject with his index finger placed at a position. As the subject lifts the finger, search time signal is recorded through oscilloscope.



Figure 9. Subject waiting for visual stimuli

Figure 10 depicts the same subject performing motor action on the basis of supplied visual stimuli. With this execution, motor action time and applied force signals are recorded through the oscilloscope.



Figure 10. Subject performing motor action

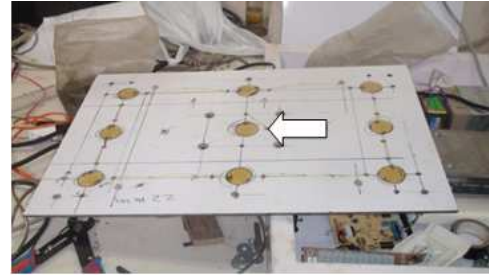

Figure 11. Load cells (piezo-electric sensors) fixed on mica-sheet

Figure 11 shows the load cells (piezo-electric sensors) arrangement which was used to fix a keyboard. Finally this structure was assembled with a self fabricated adjustable panel, to give a shape similar to a CNC machine panel.

2.6. General Experimental Procedure

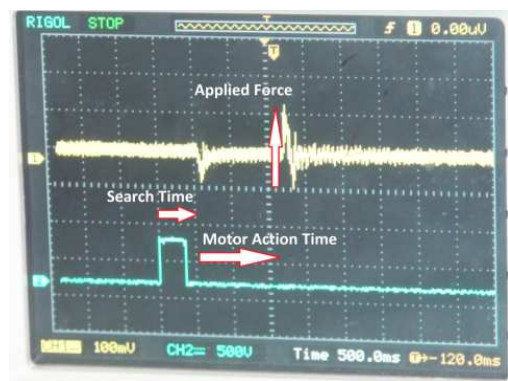

Figure 12. Recording of search time, motor action time and applied force through 2-channel Oscilloscope

Before the start of actual experimentation, a pilot study was undertaken. This helped in pre-planning the details of experimental sessions and in checking the suitability of the observation sheet designed for collecting the experimental data. For the study a sample of 27 subjects with each fulfilling the pre-specified anthropometric characteristics was selected from the pool of potential subjects, described in section 2.3. Following preparatory steps were undertaken before actually conducting the experiments:

- (1) Each subject selected for the task was briefed about the objective of the experiment.
- (2) A training session was organized for each subject in order to familiarize them with the designed CNC machine panel. Some trial runs for the experiment were undertaken for training purpose.

After the subject had stand in front of machine panel according to the selected HCI parameters and all the instructions imparted, the following steps were taken in the order, for both training as well as actual experimental sessions:

- (a) The subject was required to keep their right hand index finger on a pre-position location of the machine panel.
- (b) Through switchboard, colored visual stimuli in a randomized manner were presented to the subject by

experimenter during different sessions.

- (c) The subject responded by lifting the same index finger and pressing the required key at the CNC machine panel. The task was repeated five (for red, blue, yellow, white and green visual signal) times for each subject.
- (d) The human-performance in terms of search time, motor action time and applied force on the key of machine panel was recorded through oscilloscope against each visual signal (Figure 12).
- (e) Average of five performances was considered for the data analysis.

3. Results

3.1. Comprehension

An overview of the literature pertaining to studies on middle age operator performance in the context of HCMI environment indicated that either no or little consideration has been given to this area in researches conducted previously. On the other hand, the use of CNC machines all over the world is increasing day by day. Today a very large size of workforce is associated with the work on CNC machine tools. Automated equipment has penetrated virtually every area of human life and work environments. Human-machine interaction is already playing a vital role across the entire production process, from planning individual links in the production chain right through to designing the finished product. Innovative technology is made for humans, used by and monitored by humans. The products therefore should be reliable in operation, safe, accepted by personnel and last but not least, cost effective.

This interplay between technology and user, known as human-machine interaction, is hence at the very heart of industrial automation, automated control, and industrial production. Keeping in view these considerations, present study was designed to explore how performance of operators was affected with changing levels of machine panel height, panel angle and working distance while they worked on CNC machine tools in HCMI environment. Further, the study also aimed at to determine optimum level of machine panel height, panel angle and working distance to obtain optimal multi-performance characteristics.

To state these objectives in *statistical terms*, following *null hypothesis* was structured:

“Varying levels of CNC machine panel height, panel angle and working distance impose equal magnitude of operational loading on middle age operators resulting in no difference in human performance”.

3.2. The Experiment

Twenty seven males of age group 32-36 years selected from the pool of subjects, participated in the study. All the subjects had normal vision without lenses. The subjects chosen were right- motor sided (right hander). None had previous history of any or neuromuscular disorder.

The procedure as detailed in section 2.6 was followed for conducting the experiment and measurement of response variables the search time, motor action time and applied force. All the experimental sessions were conducted between 10.00 hours and 14.00 hours so as to have no temporal effects on the outcomes.

3.3. Data Analysis of Experimental Results

Table 2. Experimental Design using L₂₇ Orthogonal

Experiment No.	A	B	C	Search Time in milliseconds	Motor action time in milliseconds	Applied force in millivolts
1	1	1	1	850	600	150
2	1	2	2	450	600	60
3	1	3	3	850	1700	205
4	2	1	1	900	1000	180
5	2	2	2	550	850	60
6	2	3	3	400	1700	255
7	3	1	1	600	850	140
8	3	2	2	440	1200	70
9	3	3	3	800	800	140
10	1	1	2	450	700	70
11	1	2	3	800	800	235
12	1	3	1	700	1600	190
13	2	1	2	500	700	80
14	2	2	3	650	800	110
15	2	3	1	550	1660	210
16	3	1	2	440	600	60
17	3	2	3	750	950	120
18	3	3	1	440	1250	170
19	1	1	3	950	1150	120
20	1	2	1	500	1000	150
21	1	3	2	500	700	60
22	2	1	3	850	800	150
23	2	2	1	650	750	170
24	2	3	2	500	750	70
25	3	1	3	400	800	130
26	3	2	1	550	1430	210
27	3	3	2	450	650	80

Table 3. The S/N Ratios

Experiment No.	A	B	C	Search time S/N ratio (dB)	Motor action time S/N ratio(dB)	Applied force S/N ratio (dB)
1	1	1	1	-58.588	-55.563	-43.522
2	1	2	2	-53.064	-55.563	-35.563
3	1	3	3	-58.588	-64.609	-46.235
4	2	1	1	-59.085	-60.000	-45.105
5	2	2	2	-54.807	-58.588	-35.563
6	2	3	3	-52.041	-64.609	-48.131
7	3	1	1	-55.563	-58.588	-42.923
8	3	2	2	-52.869	-61.584	-36.902
9	3	3	3	-58.062	-58.062	-42.923
10	1	1	2	-53.064	-56.902	-36.902
11	1	2	3	-58.062	-58.062	-47.421
12	1	3	1	-56.902	-64.082	-45.575
13	2	1	2	-53.979	-56.902	-38.062
14	2	2	3	-56.258	-58.062	-40.828
15	2	3	1	-54.807	-64.402	-46.444
16	3	1	2	-52.869	-55.563	-35.563
17	3	2	3	-57.501	-59.554	-41.584
18	3	3	1	-52.869	-61.938	-44.609
19	1	1	3	-59.554	-61.214	-41.584
20	1	2	1	-53.979	-60.000	-43.522
21	1	3	2	-53.979	-56.902	-35.563
22	2	1	3	-58.588	-58.062	-43.522
23	2	2	1	-56.258	-57.501	-44.609
24	2	3	2	-53.979	-57.501	-36.902
25	3	1	3	-52.041	-58.062	-42.279
26	3	2	1	-54.807	-63.107	-46.444
27	3	3	2	-53.064	-56.258	-38.062

In performing the experimental task, subjects committed no error. This was ensured through a program developed in C++ language. The human performance in terms of *search time*, *motor action time* and *applied force* for different combinations of panel height, panel angle and working distance of 27 experimental runs are listed in Table 2.

The following sequential steps were adopted to determine the optimal combination of the human-CNC machine interface (HCMI) parameters for multi-performance characteristics based on Grey relational analysis:

1. Signal-to-noise (S/N) ratios for the experimental data were calculated.
2. The S/N ratios were normalized.
3. Corresponding Grey relational coefficients were determined.
4. The Grey relational grades were calculated.
5. ANOVA was carried out to determine the significant contribution of the factors.
6. Confirmation test was performed to check the validity of the results.

3.3.1. Optimal Parameter Combination

As far as human-CNC machine interaction environment is concerned, the lower search time, the lower motor action time and the lower applied force are indications of better performance. The S/N ratios of the search time, motor action time and applied force for 27 experimental runs were calculated and are listed in Table 3.

Table 4 lists all of the sequences following data pre-processing of search time, motor action time and applied

force. The deviation sequences Δ_{0i} , $\Delta_{\max}(k)$, $\Delta_{\min}(k)$ for $i=1-27$ and $k=1-3$ were calculated.

The results of all Δ_{0i} for $i=1-27$ are given in Table 5.

Table 4. Sequence of each Performance Characteristic after Data Preprocessing

Experiment No.	Search time	Motor action time	Applied force
Reference sequence	1.000	1.000	1.000
1	0.871	0.000	0.633
2	0.136	0.000	0.000
3	0.930	1.000	0.849
4	0.937	0.490	0.759
5	0.368	0.334	0.000
6	0.000	1.000	1.000
7	0.469	0.334	0.586
8	0.110	0.666	0.107
9	0.801	0.276	0.586
10	0.136	0.148	0.107
11	0.801	0.276	0.944
12	0.647	0.942	0.797
13	0.258	0.148	0.199
14	0.561	0.276	0.419
15	0.368	0.977	0.866
16	0.110	0.000	0.000
17	0.727	0.441	0.479
18	0.110	0.705	0.720
19	1.000	0.625	0.479
20	0.258	0.490	0.633
21	0.258	0.148	0.000
22	0.871	0.276	0.633
23	0.561	0.214	0.720
24	0.258	0.214	0.107
25	0.000	0.276	0.534
26	0.368	0.834	0.866
27	0.136	0.077	0.199

Table 5. The deviation sequences

Deviation sequences	$\Delta_{0i}(1)$	$\Delta_{0i}(2)$	$\Delta_{0i}(3)$
Experiment no. 1	0.129	1.000	0.367
Experiment no. 2	0.864	1.000	1.000
Experiment no. 3	0.070	0.000	0.151
Experiment no. 4	0.063	0.510	0.241
Experiment no. 5	0.632	0.666	1.000
Experiment no. 6	1.000	0.000	0.000
Experiment no. 7	0.531	0.666	0.414
Experiment no. 8	0.890	0.334	0.893
Experiment no. 9	0.199	0.724	0.414
Experiment no. 10	0.864	0.852	0.893
Experiment no. 11	0.199	0.724	0.056
Experiment no. 12	0.353	0.058	0.203
Experiment no. 13	0.742	0.852	0.801
Experiment no. 14	0.439	0.724	0.581
Experiment no. 15	0.632	0.023	0.134
Experiment no. 16	0.890	1.000	1.000
Experiment no. 17	0.273	0.559	0.521
Experiment no. 18	0.890	0.295	0.280
Experiment no. 19	0.000	0.375	0.521
Experiment no. 20	0.742	0.510	0.367
Experiment no. 21	0.742	0.852	1.000
Experiment no. 22	0.129	0.724	0.367
Experiment no. 23	0.439	0.786	0.280
Experiment no. 24	0.742	0.786	0.893
Experiment no. 25	1.000	0.724	0.466
Experiment no. 26	0.632	0.166	0.134
Experiment no. 27	0.864	0.923	0.801

Using Table 5, Δ_{max} and Δ_{min} can be determined as follows:

$$\Delta_{max} = \Delta_{06}(1) = \Delta_{01}(2) = \Delta_{02}(3) = 1.000$$

$$\Delta_{min} = \Delta_{19}(1) = \Delta_{03}(2) = \Delta_{06}(3) = 0.000$$

Table 6 lists the grey relational coefficient and grade for each experiment of the L_{27} orthogonal array.

Figure 13 shows the change in the response when factors go from one level to another. According to performed experiment design, it is clearly observed from Table 6 and the grey relational grade graph (Figure 13) that the human-CNC machine interface (HCMI) parameters' setting of experiment number 03 has the highest value (0.882) of grey relational grade. The sequence with largest grey relational grade indicates, it is the most closest to the desired values of the quality characteristics. Also, the order of grey relational grade for experiment number '03' is '1'. Thus it can be concluded that the parameter combination for $A_1B_3C_3$ has the best performance in all the three quality characteristics i.e. search time, motor action time and applied force.

The response table of Taguchi method was employed to calculate the average grey relational grade for each factor level. The procedure was to group the relational grades initially by factor level of each column in the orthogonal array and to average them. For instance, the Grey relational grade for factor C at level 1 and level 2 can be determined as follows:

$$C_1 = (0.569 + 0.686 + 0.487 + 0.731 + 0.729 + 0.543 + 0.492 + 0.521 + 0.660) / 9 = 0.602$$

$$C_2 = (0.344 + 0.401 + 0.439 + 0.365 + 0.386 + 0.342 + 0.369 + 0.383 + 0.367) / 9 = 0.377$$

Table 6. The calculated Grey relational coefficient and Grey relational grade and its orders for 27 comparability sequences

Experiment No.	Grey relational coefficient			Grey relational grade	Orders
	Search time	Motor action time	Applied force		
1	0.795	0.333	0.577	0.569	10
2	0.367	0.333	0.333	0.344	26
3	0.876	1.000	0.768	0.882	1
4	0.889	0.495	0.675	0.686	6
5	0.442	0.429	0.333	0.401	20
6	0.333	1.000	1.000	0.778	2
7	0.485	0.429	0.547	0.487	16
8	0.360	0.599	0.359	0.439	18
9	0.716	0.409	0.547	0.557	11
10	0.367	0.370	0.359	0.365	25
11	0.716	0.409	0.899	0.674	7
12	0.586	0.896	0.711	0.731	3
13	0.403	0.370	0.384	0.386	21
14	0.533	0.409	0.462	0.468	17
15	0.442	0.956	0.788	0.729	4
16	0.360	0.333	0.333	0.342	27
17	0.647	0.472	0.490	0.536	13
18	0.360	0.629	0.641	0.543	12
19	1.000	0.571	0.490	0.687	5
20	0.403	0.495	0.577	0.492	15
21	0.403	0.370	0.333	0.369	23
22	0.795	0.409	0.577	0.594	9
23	0.533	0.389	0.641	0.521	14
24	0.403	0.389	0.359	0.383	22
25	0.333	0.409	0.518	0.420	19
26	0.442	0.751	0.788	0.660	8
27	0.367	0.351	0.384	0.367	24

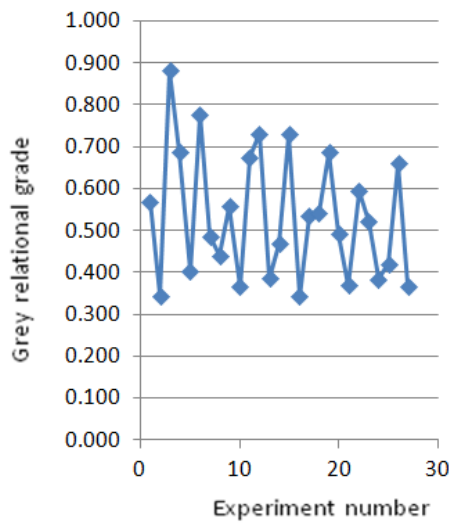

Figure 13. Graph indicating Grey Relational Grade

Using the same method, calculations were performed for each HCMI parameter level and the response table was constructed as shown in Table 7.

Since the grey relational grades represented the level of correlation between the reference and comparability sequences, the larger grey relational grade means the comparability sequence exhibits a stronger correlation with the reference sequence. Therefore, the comparability sequence has a larger value of grey relational grade for the *search time*, *motor action time* and *applied force*. Based on this hypothesis, this study selects the level that provides the largest average response. The influence of each parameter level can be more clearly presented by means of the mean grey relational grade graph (response graph). Figure 14 is the response graph for the HCMI parameters and shows mean value of grey relational grade at different levels of each HCMI parameter.

Table 7. Response table for Grey relational grade

Symbol	Human-CNC Machine Interface (HCMI) Parameter	Level 1	Level 2	Level3	Max - Min
A	CNC machine panel height	0.568	0.550	0.484	0.084
B	CNC machine panel angle	0.504	0.504	0.593	0.089
C	Working distance	0.602	0.377	0.622	0.245

Basically, the larger the grey relational grade, the better are the multi-performance characteristics. In Figure 14, the higher values indicate the low search time, motor action time and applied force. From Table 7 and Figure 14, it can be observed that A₁, B₃ and C₃ indicate the largest value of grey relational grade for factors A, B, and C respectively. Therefore, A₁B₃C₃ is the condition of optimal parameter combination for the multi-performance characteristic of HCMI environment. Restated, panel height 90 cm, panel angle 90 degrees and working distance 30 cm is the optimal parameter combination condition for the middle age (32-36 years) operators working in CNC machine environment. Further, it can be concluded that parameter combination for A₁B₃C₃ has best performance in all the three quality characteristics i.e. *search time*, *motor action time* and *applied force*. On comparison of the last column of Table 7, it is observed that the difference between the maximum and minimum value of the grey relational grade for factor C i.e. working distance, is the largest followed by factor B i.e. CNC machine panel angle and then factor A i.e. CNC machine panel height. This indicates that the *working distance* has stronger effect on the multi-performance characteristics than CNC machine *panel angle* and *panel height*. The optimum working condition obtained through present study that yields the smallest search time, smallest motor action time and smallest applied force, appears to be quite logical. For middle age group (32-36 years) males the optimum HCMI parameters combination emerged as A₁B₃C₃. At 30 cm working distance and 90 degrees CNC machine panel angle, the *shoulder and wrist abductions* were somewhat high. However, 90 cm CNC machine panel

height has resulted quite low elbow abduction. Thus, this parameter combination provides an overall less *musculoskeletal strain standing posture* for middle age males. The A₁B₃C₃ combination results optimum performance of a middle age CNC machine operator because of comfortable search, motor action and applied force environment.

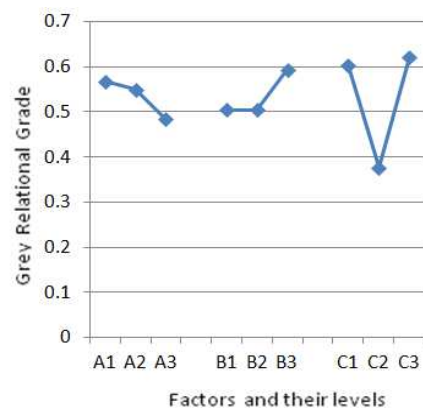

Figure 14. Effect of HCMI Parameter levels on multi-performance

To estimate parameter interaction effects, two way interaction plots were obtained using *Design-Expert software*. These plots were used to determine whether interaction between HCMI parameters significantly affects the multi-response characteristics i.e. grey relational grade. The graph for interaction between factor A (CNC machine panel height) and factor B (CNC machine panel angle) is shown in Figure 15.

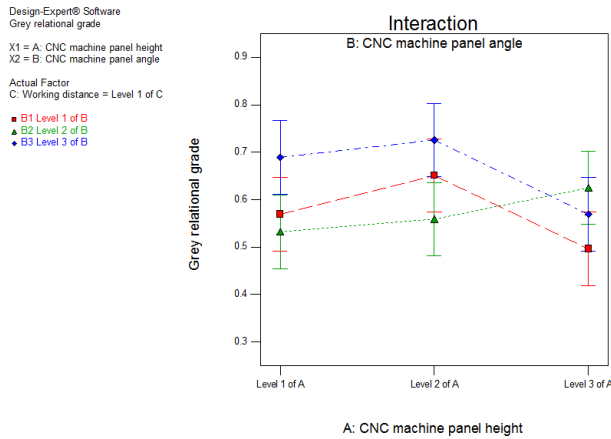

Figure 15. Interaction plot for factor A and factor B

The Figure 15 exhibits a strong interaction effect of CNC machine panel height and panel angle on the grey relational grade. Figure 15 reveals that when CNC machine panel is operated at 90 cm panel height, the multi-performance i.e. grey relational grade is the maximum at 90 degrees panel angle followed by 30 and 60 degrees, respectively. The status of grade remain same at 110 cm panel height while as, at 130 cm panel height the grey relational grade is maximum at 60 degrees panel angle followed by 90 and 30 degrees. It is significant to note that, corresponding to all the panel angles, the grade increases when machine operation is shifted from 90 to 110 cm panel height. Further, at panel angles 90 and 30 degrees, the grade, decreases when operation is moved from 110 to 130 cm panel height but increases for 60 degrees panel angle. It is also interesting to observe that the multi-performance characteristics of HCMI are significantly affected by the panel heights when the CNC machine is operated at 90 and 30 degrees panel angles.

It can be concluded that the *minimum musculoskeletal strain posture* for middle age group males emerged at 110 cm CNC machine panel height for all the three panel angles followed by 90 cm and 130 cm panel heights, respectively.

The graph for interaction between factor A (CNC machine panel height) and factor C (working distance) is shown in Figure 16.

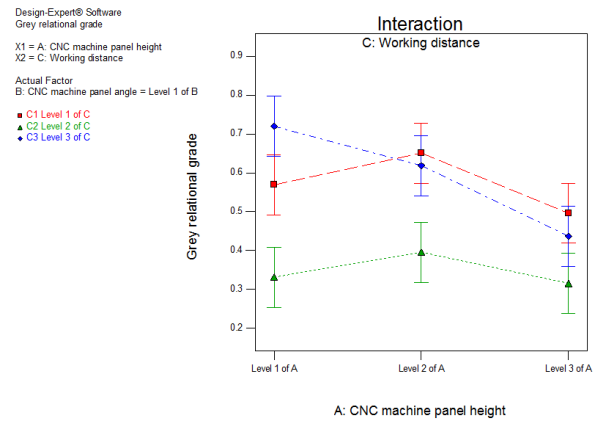

Figure 16. Interaction plot for factor A and factor C

The Figure 16 depicts that the interaction between CNC machine panel height and working distance has a strong effect on the grey relational grade. Figure 16 indicates that when CNC machine is operated at 90 cm panel height, the multi-performance i.e. grey relational grade is the maximum at 30 cm working distance followed by 10 and 20 cm, respectively. The status of grade at 110 and 130 cm panel heights is that, it is highest at 10 cm working distance followed by 30 and 20 cm, respectively. It is significant to note that, at working distance 30 cm, the grade decreases continuously as panel angle increases. Furthermore, significant increase in grade is observed at 10 and 20 cm working distances when CNC machine operation is shifted from 90 to 110 cm panel height, while as a decrease in grade is resulted when operation of the machine is shifted from 110 to 130 cm panel height. It is pertinent to note that the multi-performance characteristics of HCMI are marginally affected by the panel heights when CNC machine is operated from a distance of 20 cm.

It can be concluded that the *minimum musculoskeletal strain posture* for middle age group males emerged, at 110 cm CNC machine panel height for working distances 10 and 20 cm and at 90 cm panel height for 30 cm working distance.

The graph for interaction between factor B (CNC machine panel angle) and factor C (working distance) is shown in Figure 17.

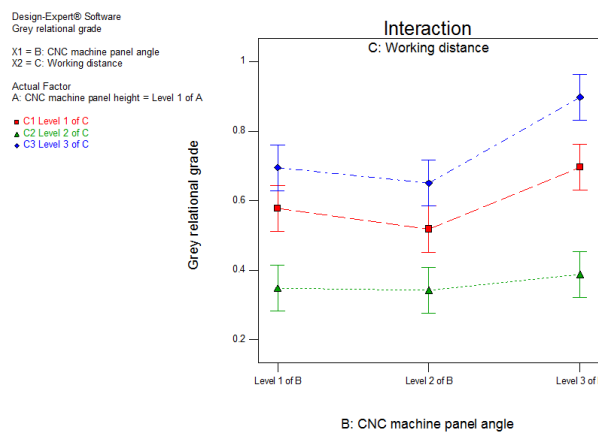

Figure 17. Interaction plot for factor B and factor C

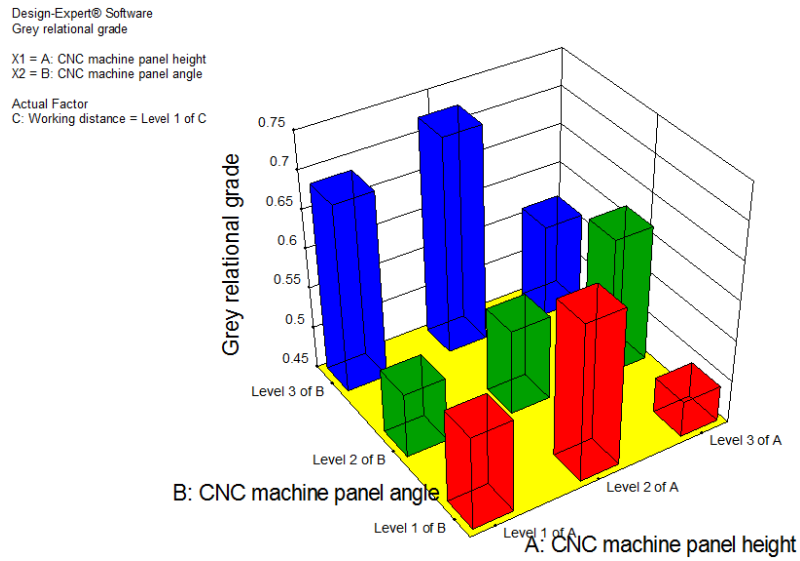

Figure 18. General factorial effects of interaction between CNC machine panel height and panel angle

Figure 17 indicates that all lines in the plot fall parallel to each other. Therefore, it can be concluded that the Figure 17 exhibit non- significant interaction between factor B and factor C. Hence this interaction was ignored in the analysis of variance (ANOVA).

Figure 18 shows three-dimensional (3D) view of general factorial effects of interaction between CNC machine panel height and panel angle.

Higher elbow abduction at higher CNC machine panel height results uncomfortable working posture while as, at low panel angles the wrist abduction is lower thus results higher human performance. The Figure 18 reveals that the lowest human performance emerged at CNC machine panel height of 130 cm used with panel angle of 30 degrees while as, highest performance is resulted at panel height of 110 cm when combined with panel angle of 90 degrees. Furthermore, higher moderate performance observed at

CNC machine panel height and angle combinations of 90cm and 90 degrees, 110 cm and 30 degrees and 130 cm and 60 degrees, respectively. While as, lower moderate performance resulted at CNC machine panel height and angle combinations of 130 cm and 90 degrees, 90 cm and 30 degrees, 110 cm and 60 degrees and 90 cm and 60 degrees, respectively. It can be concluded on the basis of 3D factorial effects that overall performance of middle age group males was better due to low wrist muscular strain at CNC machine panel angle 90 degrees irrespective of panel heights. Also, the overall performance was better because of moderate elbow abduction at CNC machine panel height of 110 cm irrespective of panel angles. Figure 19 shows three-dimensional (3D) view of general factorial effects of interaction between CNC machine panel height and working distance.

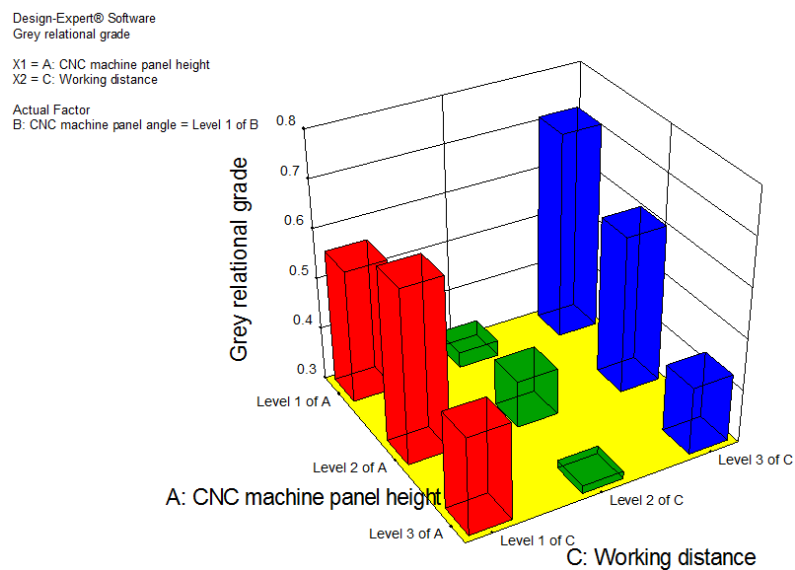

Figure 19. General factorial effects of interaction between CNC machine panel height and working distance

The Figure 19 reveals that the lowest human performance resulted because of higher elbow muscles fatigue at CNC machine panel height 130 cm used with working distance 20 cm also the performance was low at panel height 90 cm and working distance 20 cm due to higher shoulder muscles strain. While as, highest human performance is resulted due to low elbow abduction at panel height 90 cm when combined with working distance 30 cm. Furthermore, higher moderate performance exhibited at CNC machine panel height and working distance combinations of 110 cm and 10 cm, 110 cm and 30 cm and 90 cm and 10 cm, respectively. However, lower moderate performance emerged at CNC machine panel

height and working distance combinations of 130 cm and 10 cm, 130 cm and 30 cm and 110 cm and 20 cm, respectively. It can be concluded on the basis of 3D factorial effects that in this study, the overall performance of middle age group males was better even at higher shoulder abduction at working distance 30 cm irrespective of CNC machine panel heights.

The residuals of multi-performance characteristic (grey relational grade) were checked to make sure that various assumptions were satisfied. To carry out some *model adequacy or diagnostic*, checks were made using *Design Expert software*. Figure 20 shows normal probability graph of studentized residuals.

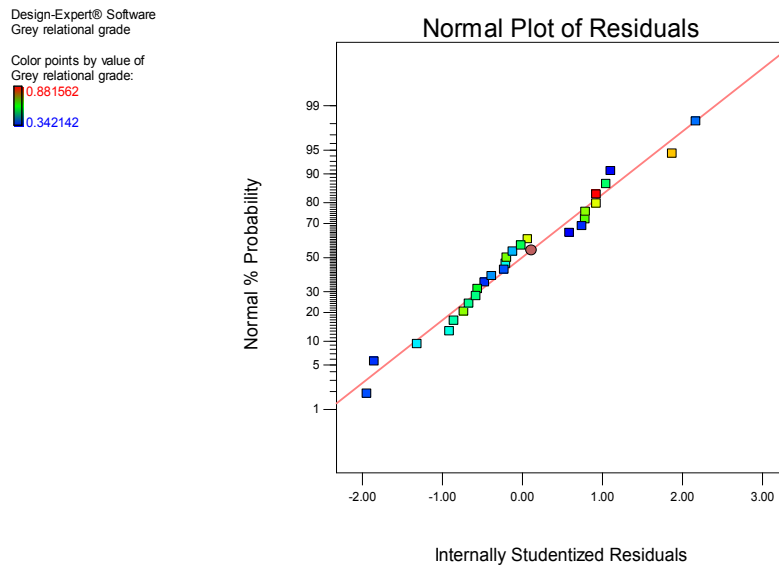

Figure 20. Normal probability plot of studentized residuals

From the Figure 20 it is evident that the normal plot of residuals ideally fall more-or-less in line. Also it is indicated that the pattern here is not badly abnormal and the residuals follow a normal distribution. On observing the normal probability graph, it can easily be concluded that the assumption of normality was found to be satisfactory.

3.3.2. Analysis of Variance

Analysis of variance (ANOVA) and F-test were used to find out the significant HCMI parameters. Results of the ANOVA carried out using *Design-Expert software* are presented in the Table 8.

Table 8. Results of the analysis of variance

Symbol	HCMI parameters	Degrees of freedom	Sum of square	Mean square	F- ratio	P-value	Contribution (%)
A	CNC machine panel height	2	0.035	0.018	3.90	0.049	5.93
B	CNC machine panel angle	2	0.048	0.024	5.26	0.023	8.13
C	Working distance	2	0.33	0.17	36.5	<0.01	55.93
AxB	Inter-action between panel height and angle	4	0.060	0.015	3.28	0.049	10.16
AxC	Inter-action between panel height and working distance	4	0.065	0.016	3.60	0.038	11.01
Error		12	0.054	4.540E-003			9.15
Total		26	0.59				100.31

The purpose of ANOVA was to investigate which human-CNC machine interface (HCMI) parameter/s significantly affected the multi-performance characteristics.

This was accomplished by separating the total variability of the grey relational grades, which was determined by sum of the square deviations from the total mean of the grey

relational grade, into contributions by each HCMI parameter and the error. Percentage contribution by each of the parameter in total sum of squared deviations was used to evaluate the importance of HCMI parameter change on the performance characteristic. In addition, the F-test was used to determine which HCMI parameter had a significant effect on performance characteristic. Usually, the change of the HCMI parameter has a significant effect on performance characteristic when the F-value is large. Table 8 indicates that F-value is highest for parameter working distance. The results of ANOVA for the grey relational grade are listed in Table 8.

It can be concluded from the ANOVA results that all the three HCMI parameters i.e. CNC machine *panel height*, *panel angle* and *working distance* and two interactions i.e. between CNC machine panel height and panel angle and between CNC machine panel height and working distance, significantly affected the multi-performance characteristics of the human-CNC machine interaction environment. The interaction (Figure 17) between CNC machine panel angle and working distance is *non-significant*, hence this

interaction was ignored in the analysis of variance (ANOVA). The results also reveal that *working distance* is the most significant HCMI parameter affecting the multi-performance characteristic due to its highest percentage contribution (55.93%) amongst the selected parameters. Table 9 further shows that the percentage contribution of other parameters in decreasing order is interaction between CNC machine panel height and working distance (11.01%), interaction between CNC machine panel height and panel angle (10.16%), CNC machine panel angle (8.13%) and CNC machine panel height (5.93%).

3.3.3. Confirmation Test

After determining the optimal level of the human-CNC machine interface parameters, the next step is to verify the percentage change of grey relational grade between predicted and experimental values for the optimal combination. Table 9 compares the results of the confirmation experiment using the optimal HCMI parameters ($A_1B_3C_3$) obtained through the proposed method.

Table 9. Results of confirmation test

	Optimal HCMI parameters		
	Prediction	Experiment	improvement
Level	$A_1B_3C_3$	$A_1B_3C_3$	
Search time	480 ms	850 ms	
Motor action time	1040 ms	1700	
Applied force	250 mv	205 mv	
Grey relational grade	0.625	0.882	41.12

As shown in Table 9, the grey relational grade improved from 0.625 to 0.882 (an improvement of 41.12%), which indicate that optimal combination of the human-CNC machine interface parameters is good enough to meet the requirement.

4. Discussion

Designing human-machine interfaces that respect the ergonomic norms and following rigorous approaches constitute a major concern for automated systems designers. The increased need on easily accessible and usable interfaces leads researchers in this domain to create methods and models that make it possible to evaluate these interfaces in terms of utility and usability.

Present study explored that the performance of middle age group (32- 36 years) males significantly affected when CNC machine *panel height*, *panel angle* and *working distance* is varied. The measure of human performance, in the present study, constituting the dependent variables, was *search time*, *motor action time* and *applied force* on the CNC machine panel keys. Results on the basis of multi-performance characteristic indicated that males of age group 32-36 years differ significantly in their performance at the investigated levels of CNC machine panel height,

panel angle and working distance. The findings of this study indicated that the optimum combination of HCMI parameters would be a CNC machine panel height of 90 centimeters, a panel angle of 90 degrees and a working distance of 30 centimeters. The study also indicated significant interaction effects, between CNC machine panel height and panel angle and between CNC machine panel height and working distance. However, the finding reported non-significant interaction effect between CNC machine panel angle and working distance. The performed confirmation test indicated that optimal combination of the human-CNC machine interface parameters is good enough to meet the requirement.

It is essential from the ergonomic point of view that the work place design of a CNC machine environment be compatible with the biological and psychological characteristics of the operators. The effectiveness of the human-CNC machine combination can be greatly enhanced by treating the operator and the CNC machine as a unified system. When the CNC operator is viewed as one component of a HCMI system, the human characteristics pertinent to the ergonomic design are physical dimensions, capabilities for data sensing, for data processing, for learning etc. Quantitative information about these human characteristics must be co-ordinate with the data on CNC machine

characteristics, if maximum human-machine integration is to be achieved. It is observed that the application of ergonomics in the design of human-CNC machine interface not only would help to increase machine performance and productivity, but also help human operator to be comfortable and secure. Since nowadays, majority of the companies acquired CNC machines in order to be competitive, it is strongly suggested that the ergonomic and safety aspects must thoroughly be considered.

In this study, the effect of panel height, panel angle and working distance on performance of CNC machine operators was explored under the influence of search time, motor action time and applied force on the keys of machine panel. Subjects were selected as male of age group 32-36 years. In this study the considered variables, CNC machine panel height, panel angle and working distance were found to be statistically significant. These significant anthropometric factors must be given due consideration in the ergonomic design of human-CNC machine interface environment. Moreover, these findings implied that the working distance is the most significant factor as compared to CNC machine panel height and panel angle. In addition, out of three interactive effects, the two interactions i.e. between CNC machine panel height and panel angle and between CNC machine panel height and working distance were found to be statistically significant while as, the interaction between CNC machine panel angle and working distance was statistically non-significant. Analysis of results further revealed that the factor CNC machine panel height had a significant effect at all the three levels of panel angle, explored in the present study. Further, for all the three levels of working distance, the factor CNC machine panel height emerged significant.

5. Conclusions

This study has presented an effective approach for the optimization of the human-CNC machine interface environment with multi-performance characteristics based on the combined Taguchi method and Grey relational analysis. Based on the results of the present study, the following conclusions are drawn:

1. The combination of parameters and their levels for the optimum multi-performance characteristics of human-CNC machine interface environment are A1B3C3 (i.e. CNC machine panel height of 90 cm, panel angle of 90 degrees and working distance of 30 cm).
2. There appears a significant effect of panel height on operator's performance while working on CNC machines. This implies that on the basis of multi-performance characteristic, CNC machine panel height seem to be an important factor to be considered in the ergonomic design of the HCMI environment.
3. The levels of CNC machine panel angle significantly affect the operator's performance in the HCMI environment. It is therefore, concluded that panel angle must be given due consideration in the ergonomic

design of the CNC machine interface environment.

4. The working distance appeared to be a significant factor in HCMI environment associated with the present study and therefore, it is suggested the impact of working distance should not be ignored in the context of designing an HCMI environment.
5. The percentage contributions of working distance, CNC machine panel angle and panel height are 55.93, 8.13 and 5.93, respectively.
6. An improvement of 41.12% in the multi-performance characteristics, i.e. Grey relational grade was achieved through this approach.
7. The minimum musculoskeletal strain posture for middle age group males emerged at 110 cm CNC machine panel height for 30, 60 and 90 degrees panel angles followed by 90 cm and 130 cm panel heights, respectively.
8. The anthropometrically comfortable posture for middle age group males emerged at 110 degrees CNC machine panel height for working distances 10 and 20 cm and at 90 cm panel height for 30 cm working distance.
9. On the basis of significant interaction effect between CNC machine panel height and panel angle (10.16% contribution), it is concluded that there exists an ergonomic database in the form an optimal CNC machine panel height for a particular panel angle and vice-versa.
10. The significant interaction effect between CNC machine panel height and working distance (11.01% contribution) also indicated an important ergonomic database in the form of an optimal CNC machine panel height for a particular working distance and vice-versa.
11. The interaction effect between CNC machine panel angle and working distance appeared non-significant in this study. Therefore, this effect may be ignored for males of middle age group 32-36 years in the context of designing an HCMI environment.

References

- [1] Bautmans et al., 2011 I. Bautmans, S. Vantieghem, E. Gorus, Yuri-Reva Grazzini, Y. Fierens, A. Pool-Goudzwaard and T. Mets, Age-related differences in pre-movement antagonist muscle co-activation and reaction-time performance. *Journal of Experimental Gerontology*, 46 8 (2011), pp. 637-642.
- [2] Bedny and Karwowski, 2006 G. Bedny and W. Karwowski, A systematic-structural theory of activity: Applications to human performance and work design, CRC Press (2006), Boca Raton.
- [3] Bergmann et al., 2011 G. Bergmann, F. Graichen, A. Bender, A. Rohlmann, A. Halder, A. Beier and P. Westerhoff, In vivo gleno-humeral joint loads during forward flexion and abduction. *Journal of Biomechanics*, 44 8 (2011), pp. 1543-1552.

- [4] Bothell, 2004 D. Bothell, Act-r 6.0 Reference Manual. Working Draft, Carnegie Mellon University.
- [5] Chen and Chiang, 2011 Chien-Hsiung Chen and Shu-Ying Chiang, The effects of Panel arrangement on search performance. *Journal of Displays*, 32 5 (2011), pp. 254-260.
- [6] Chen et al., 1994 H.C. Chen, J.A. Ashton-Miller, N.B. Alexander and A.B. Schultz, Effects of age and available response time on ability to step over an obstacle. *Journal of Gerontol*, 49 (1994), pp. M227-M233.
- [7] Chikhaoui and Pigot, 2010 B. Chikhaoui and H. Pigot, Towards analytical evaluation of human machine interfaces developed in the context of smart homes. *Journal of Interacting with Computers*, 22 6 (2010), pp. 449-464.
- [8] Choi et al., 2010 J.H. Choi, Sung-Woo Park, Seung-Yeob Baek and K. Lee, Evaluation of handheld products by computing user hand fatigue. *Journal of Simulation Modelling Practice and Theory*, 18 2 (2010), pp. 230-239.
- [9] Chung et al., 2010 M.K. Chung, D. Kim, S. Na and D. Lee, Usability evaluation of numeric entry tasks on keypad type and age. *Industrial Ergonomics*, 40 1 (2010), pp. 97-105.
- [10] Cousins et al., 1998 M.S. Cousins, C. Corrow, M. Finn and J.D. Salamone, Temporal measures of human finger tapping: effects of age. *Journal of Pharmacology Biochemistry and Behavior*, 59 (1998), pp. 445-449.
- [11] Dartt et al., 2009 A. Dartt, J. Rosecrance, F. Gerr, P. Chen, D. Anton and L. Merlino, Reliability of assessing upper limb postures among workers performing manufacturing tasks. *Applied Ergonomics*, 40 3 (2009), pp. 371-378.
- [12] Design Expert Software, 2012 Design Expert Software, Version 8.0.7.1 (2012), <http://www.statease.com>.
- [13] Elias et al., 1993 M.F. Elias, M.A. Robbins, L.J. Walter and N.R. Schultz Jr., The influence of gender and age on Halstead-Reitan neuropsychological test performance. *Journal of Gerontol*, 48 (1993), pp. 278-281.
- [14] Endrass et al., 2012 T. Endrass, M. Schreiber and N. Kathmann, Speeding up older adults: Age-effects on error processing in speed and accuracy conditions. *Journal of Biological Psychology*, 89 2 (2012), pp. 426-432.
- [15] Germine et al., 2011 L.T. Germine, B. Duchaine and K. Nakayama, Where cognitive development and aging meet: Face learning ability peaks after age 30. *Journal of Cognition*, 118 2 (2011), pp. 201-210.
- [16] Goel et al., 2011 P. Goel, Z.A. Khan, A.N. Siddiquee, S. Kamaruddin and R.K. Gupta, Influence of slab milling process parameters on surface integrity of HSLA: a multi-performance characteristic optimization. *Journal of Advanced Manufacturing Technology*, (2011), DOI 10.1007/s00170-011-3763-y, Published online 22.11.2011.
- [17] Goldhammer et al., 2010 F. Goldhammer, W.A. Rauch, K. Schweizer and H. Moosbrugger, Differential effects of intelligence, perceptual speed and age on growth in attentional speed and accuracy. *Journal of Intelligence*, 38 1 (2010), pp. 83-92.
- [18] Hansson et al., 2010 Gert-Ake Hansson, I. Balogh, K. Ohlsson, L. Granqvist, C. Nordander, I. Arvidsson, I. Akesson, J. Unge, R. Rittner, U. Stromberg and S. Skerfving, Physical workload in various types of work: Part II. Neck, shoulder and upper arm. *Industrial Ergonomics*, 40 3 (2010), pp. 267-281.
- [19] Hawthorn, 2000 D. Hawthorn, Possible implications of aging for interface designers. *Journal of Interacting with Computers*, 12 5 (2000), pp. 507-528.
- [20] Hermsdorfer et al., 1999 J. Hermsdorfer, C. Marquardt, S. Wack and N. Mai, Comparative analysis of diadochokinetic movements. *Electromyography and Kinesiology*, 9 (1999), pp. 283-295.
- [21] Imtiaz and Asghar, 2010 Imtiaz A. Khan and Mohd. Asghar, Ergonomic evaluation of the angle of abduction in a computer numerically controlled electro discharge machine environment. *Journal of Cognition Technology & Work*, 12 4 (2010), pp. 263-269.
- [22] Imtiaz and Asghar, 2011 Imtiaz A. Khan and Mohammad Asghar, Ergonomic design of the viewing angle in a computer numerically controlled electro discharge machine environment, Waldemar Karwowski, Gavriel Salvendy, Editors, *Advances in Human Factors, Ergonomics and Safety in Manufacturing and Service Industries*, CRC Press, Taylor & Francis Group, New York (2011), pp. 169-179.
- [23] Imtiaz and Saraswat, 2009 Imtiaz A. Khan and S. Saraswat, Role of ergonomists in automated industries. *Proceedings: All India Seminar on Ergonomics for Improved Productivity, Aligarh 202002 India*, (2009), pp. 177-182.
- [24] Imtiaz, 2012 Imtiaz A. Khan, Ergonomic design of human-CNC machine interface, Inaki Maurtua, Editor, *Human Machine Interaction-Getting Closer*, InTech Open Access Publisher, Croatia (2012), pp. 115-136.
- [25] Jimenez-Jimenez et al., 2011 F.J. Jimenez-Jimenez, M. Calleja, H. Alonso-Navarro, L. Rubio, F. Navacerrada, B. Pilo-de-Fuente, J.F. Plaza-Nieto, M. Arroyo-Solera, P.J. Garcia-Ruiz, E. Garcia-Martin and J.A.G. Agundez, Influence of age and gender in motor performance in healthy subjects. *Journal of Neurological Sciences*, 302 1-2 (2011), pp. 72-80.
- [26] Kang and Yoon, 2008 N.E. Kang and W.C. Yoon, Age- and experience-related user behavior differences in the use of complicated electronic devices. *Journal of Human-Computer Studies*, 66 6 (2008), pp. 425-437.
- [27] Kee and Lee, 2012 D. Kee and I. Lee, Relationships between subjective and objective measures in assessing postural stresses. *Applied Ergonomics*, 43 2 (2012), pp. 277-282.
- [28] Kim et al., 2009 H.K. Kim, S. Park and M.A. Srinivasan, Developments in brain-machine interfaces from the perspective of robotics. *Journal of Human Movement Science*, 28 2 (2009), pp. 191-203.
- [29] King and Fries, 2009 Paul H. King and Richard C. Fries, *Design of biomedical devices and systems*, CRC Press, Taylor & Francis Group, New York (2009), pp. 146.
- [30] Koo and Mak, 2005 Terry K.K. Koo and Arthur F.T. Mak, Feasibility of using EMG driven neuromusculoskeletal model for prediction of dynamic movement of the elbow. *Electromyography and Kinesiology*, 15 1 (2005), pp. 12-26.
- [31] Layer et al., 2009 J.K. Layer, W. Karwowski and A. Furr, The effect of cognitive demands and perceived quality of work life on human performance in manufacturing environments. *Industrial Ergonomics*, 39 2 (2009), pp. 413-421.

- [32] Lindberg et al., 2006 T. Lindberg, R. Nasanen and K. Muller, How age affects the speed of perception of computer icons. *Journal of Displays*, 27 4-5 (2006), pp. 170-177.
- [33] Lin et al., 2010 Chih-Long Lin, Mao-Jiun J. Wang, C.G. Drury and Yu-Sheng Chen, Evaluation of perceived discomfort in repetitive arm reaching and holding tasks. *Industrial Ergonomics*, 40 1 (2010), pp. 90-96.
- [34] Maldonado-Macias et al., 2009 A. Maldonado-Macias, M.G. Ramirez, J.L. Garcia, J.J. Diaz and S. Noriega, Ergonomic evaluation of work stations related with the operation of advanced manufacturing technology equipment: Two cases of study. XV Congreso Internacional de ergonomia SEMAC, (2009).
- [35] Nissen and Corkin, 1985 M.J. Nissen and S. Corkin, Effectiveness of attentional cueing in older and younger adults. *Journal of Gerontol*, 40 (1985), pp. 185-191.
- [36] OSHA, 2011 OSHA, Occupational Safety and Health Administration, website <http://www.dazor.com/OSHA.pdf> as browsed on 18.11.2011.
- [37] Pelosi and Blumhardt, 1999 L. Pelosi and L.D. Blumhardt, Effects of age on working memory: an event-related potential study . *Journal of Cognitive Brain Research*, 7 3 (1999), pp. 321-334.
- [38] Ruff and Parker, 1993 R.M. Ruff and S.B. Parker, Gender- and age-specific changes in motor speed and eye-hand coordination in adults: normative values for the finger tapping and grooved pegboard tests. *Percept Motor Skills*, 76 (1993), pp. 1219-1230.
- [39] Samant et al., 2008 A.N. Samant, S.R. Paital and N.B. Dahotre, Process optimization in laser surface structuring of alumina. *Journal of Materials Processing Technology*, 203 (2008), pp. 498-504.
- [40] Sanders and McCormick, 1992 M.S. Sanders and E.J. McCormick, *Human factors in engineering and design*, 7th ed. (1992), NY: McGraw-Hill.
- [41] Seidler et al., 2010 R.D. Seidler, J.A. Bernard, T.B. Burutolu, B.W. Fling, M.T. Gordon, J.T. Gwin, Y. Kwak and D.B. Lipps, Motor control and aging: Links to age-related brain structural, functional and biochemical effects. *Neuroscience & Behavioral Reviews*, 34 5 (2010), pp. 721-733.
- [42] Serna et al., 2007 Audrey Serna, H. Pigot and V. Rialle, A computational model of activities performance decrease in Alzheimer's disease. *Journal of Medical Informatics*, 76 3 (2007), pp. S377-S383.
- [43] Shimoyama et al., 1990 I. Shimoyama, T. Ninchoji and K. Uemura, The finger-tapping test: A quantitative analysis. *Arch Neurol*, 47 (1990), pp. 681-684.
- [44] Span et al., 2004 M.M. Span, K.R. Ridderinkhof and M.W. van der Molen, Age-related changes in the efficiency of cognitive processing across the life span. *Journal of Acta Psychologica*, 117 2 (2004), pp. 155-183.
- [45] Straker et al., 2009 L. Straker, R. Burgess-Limerick, C. Pollock and B. Maslen, The influence of desk and display design on posture and muscle activity variability whilst performing information technology tasks. *Applied Ergonomics*, 40 5 (2009), pp. 852-859.
- [46] Vieira and Kumar, 2007 E.R. Vieira and S. Kumar, Occupational risks factors identified and interventions suggested by welders and computer numeric control workers to control low back disorders in two steel companies. *Industrial Ergonomics*, 37 6 (2007), pp. 553-561.
- [47] Yang et al., 2006 Y.Y. Yang, J.R. Shie and C.H. Huang, Optimization of dry machining parameters for high purity graphite in end-milling process. *Journal of Materials and Manufacturing Processes*, 21 (2006), pp. 832-837