

Particular Transient Regimes of Asynchronous Motors Supplied by PWM Converters

Monica-Adela Enache, Sorin Enache, Ion Vlad, Gheorghe-Eugen Subtirelu

University of Craiova, Faculty of Electrical Engineering, Craiova, Romania

Email address:

menache@em.ucv.ro (M. A. Enache), senache@em.ucv.ro (S. Enache), ivlad@em.ucv.ro (I. Vlad),

esubtirelu@em.ucv.ro (G. E. Subtirelu)

To cite this article:

Monica-Adela Enache, Sorin Enache, Ion Vlad, Gheorghe-Eugen Subtirelu. Particular Transient Regimes of Asynchronous Motors Supplied by PWM Converters. *Journal of Electrical and Electronic Engineering*. Vol. 3, No. 1, 2015, pp. 6-11. doi: 10.11648/j.jeee.20150301.12

Abstract: This paper presents a few aspects regarding the analysis of some dynamic regimes of asynchronous motors supplied at variable frequency. In this purpose, in the first part of the paper, there are detailed the Simulink blocks of a program for simulating the operation of driving systems with static converters with precomputed commutation moments. Then there are presented the simulations obtained with the help of this program in case when the supply frequency is modified by jump. The accent is laid on the rate of time-dependent variation of the stator current. The results obtained are compared with the experimental results obtained with the help of a high-speed data acquisition board. The paper ends with conclusions and references.

Keywords: Asynchronous Motors, Dynamic Regimes, Simulation, Test

1. Introduction

The problem of optimal control of an asynchronous machine is a very present one; this fact is confirmed by several papers published in outstanding reviews [2], [7], [10] etc. and presented in important international conferences [1], [5], [6], [9], [11], [14] etc.

In comparison with other types of control, PWM control has the advantage that the motor current has a lower content in harmonics, fact materialized in a decrease of the supplementary losses, of the torque pulsations etc.

Along the time there have been formulated a lot of modulation strategies, both analogical and numerical. Among them, the precomputed PWM modulation for harmonics elimination has imposed; in this case, the commutation moments are established analytically, they are memorized and read with variable frequency.

For determining the commutation moments, the line voltage rate is imposed to be symmetrical to $\pi/2$ and to contain a certain number of pulses characterized by angles α_1 , α_2 etc.

Moreover, the amplitude of the fundamental must have the value wanted and as many as possible of the superior harmonics must be null.

It must be emphasized that, owing to the type of the stator

winding connection of asynchronous motor, the harmonics which are multiple of three will not occur in the current curve, fact that does not impose supplementary measures for decreasing them.

2. Converter Modelling

The converter with precomputed commutation moments is part of the driving system detailed in figure 1.

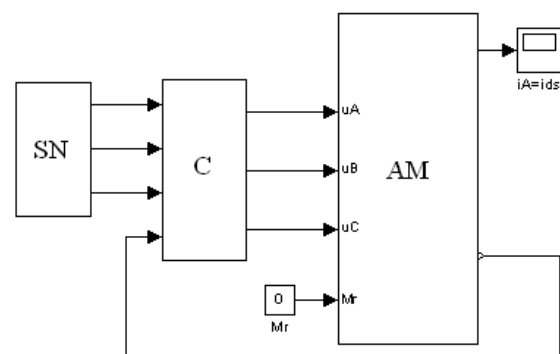


Figure 1. Structure of driving system: SN-supply network, C-converter; AM-asynchronous motor.

A variant of a Simulink model of the analyzed converter will be presented further on.

The Simulink block corresponding to this converter will be composed of other three blocks which simulate the operation of rectifier, filter and inverter from its composition.

2.1. Modelling of Inverter with Precomputed Duration Modulation with Harmonics Elimination

In order to allow the modification of the root-mean-square

value of the output voltage of inverter (according to [8]) there is used an overmodulation signal with adjustable filling factor and frequency. Using the notions presented before there has been obtained the Simulink model of the voltage inverter with precomputed commutation moments presented in figure 2.

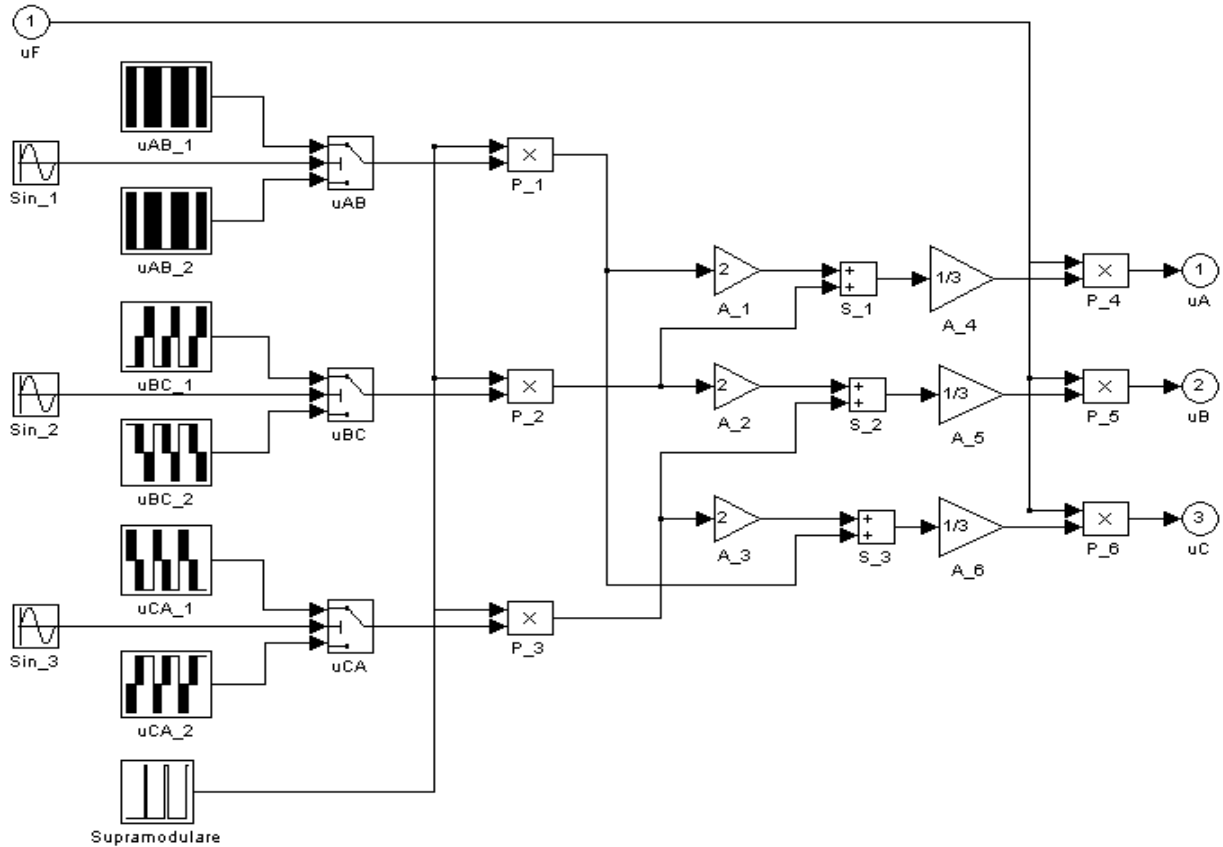


Figure 2. Simulink model of inverter.

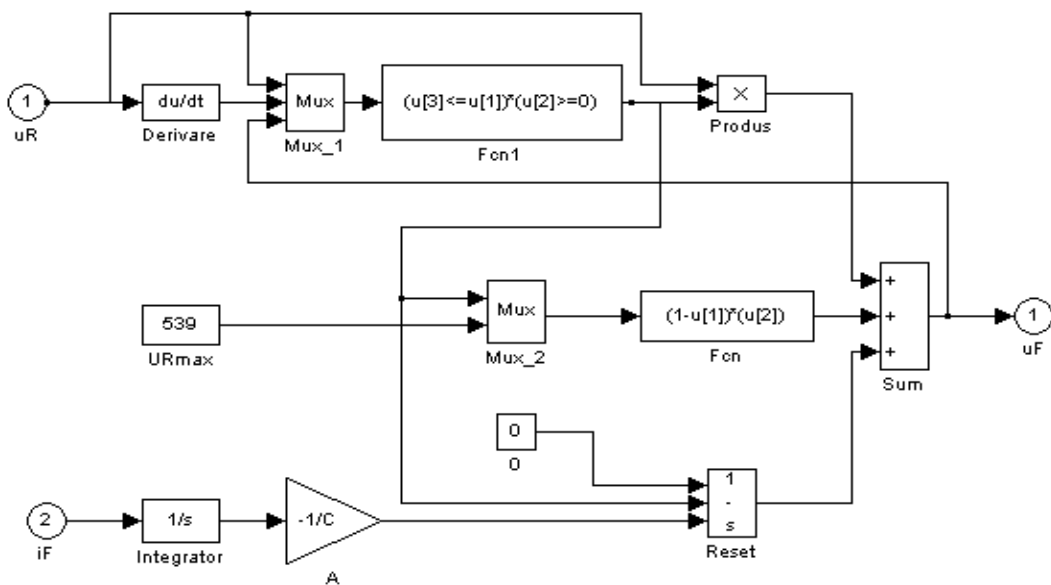


Figure 3. Block scheme of the capacitive filter.

2.2. Simulink Model of the Intermediary Circuit

For carrying out this model, [3] has been used.

In these conditions, the Simulink model of the capacitive filter from the intermediary circuit has the form presented in figure 3.

2.3. Modelling of Rectifier

The rectifier modelling has been carried out starting from one of the observations presented before, that in case of the converter we analyzed, the voltage of the intermediary circuit is practically constant. It results that the rectifier used will always be uncontrolled.

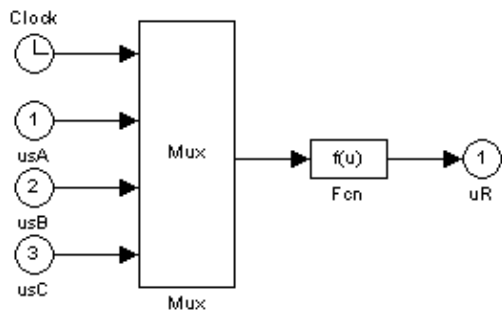


Figure 4. Simulink model of rectifier.

Moreover, this is considered as being a three-phase bridge rectifier, with direct feed to network. Considering that it could be equivalent to two middle-point rectifiers connected in series delivering to the same load, the following block scheme is obtained [4].

3. Motor Modelling

The motor modelling has been carried out starting from the mathematical model written in the two-axes theory.

With the help of this model the block scheme presented in figure 5 has been obtained. The input quantities of this block are the phase voltages (provided by three Simulink blocks from the available programs library) and the resistant torque M_r (considered equal to zero in our simulations).

As output quantities, certain currents, the angular speed and the electromagnetic torque m in dynamic regime are provided.

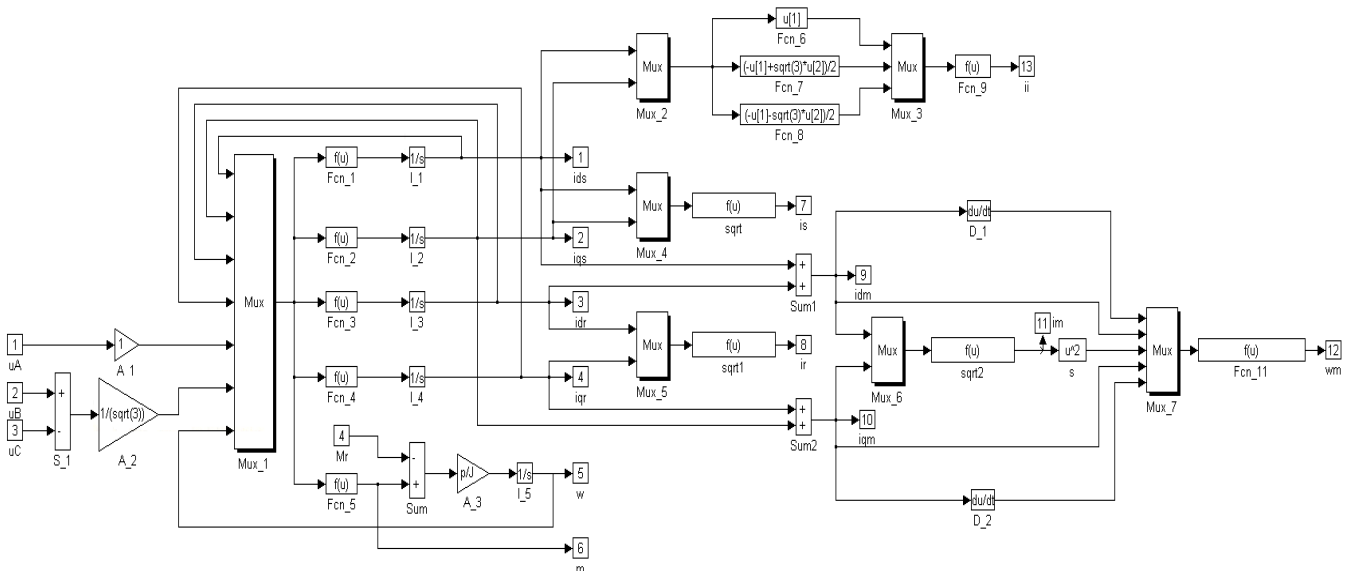


Figure 5. Simulink model of asynchronous motor.

4. Simulations

Running the program detailed before, for several particular values of the parameters of an asynchronous motor rated at 1,2 kW (at 15 Hz), the graphics from figures 6 and 7 have been obtained.

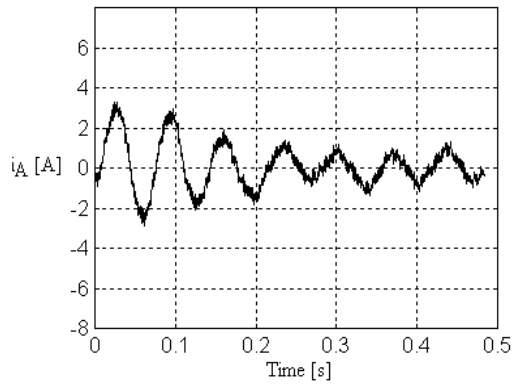
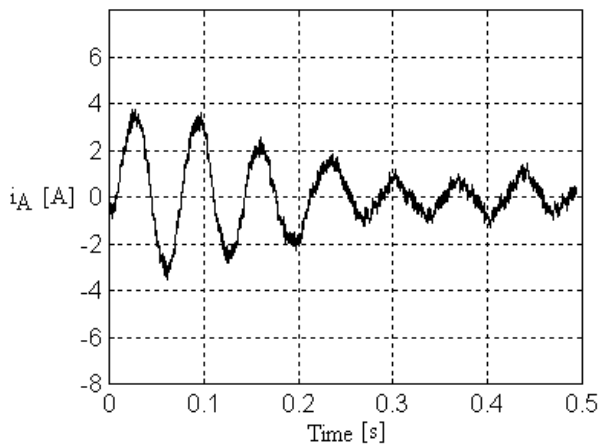
a) $R_r=5,5 \Omega$ (cage made of aluminium)b) $R_r=3,2 \Omega$ (cage made of copper)

Figure 6. Time-dependent variations of the current of phase A for cases when the rotor resistance value is modified ($J=0,006 \text{ Nm}$).

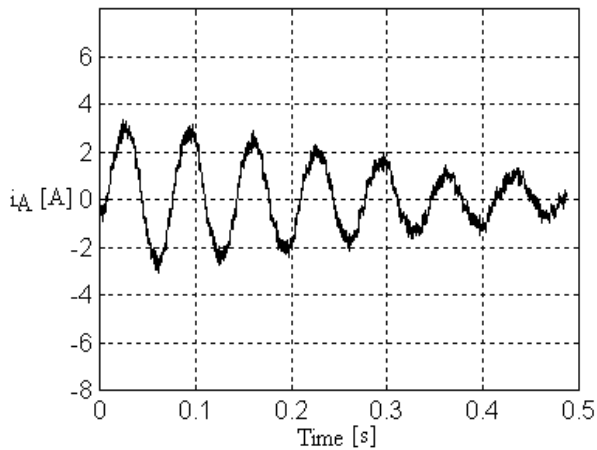


Figure 7. Time-dependent variation of the current of phase A corresponding to the inertia moment modification to the value $J=0,012 \text{ Nm}$ ($R_r=5,5 \Omega$).

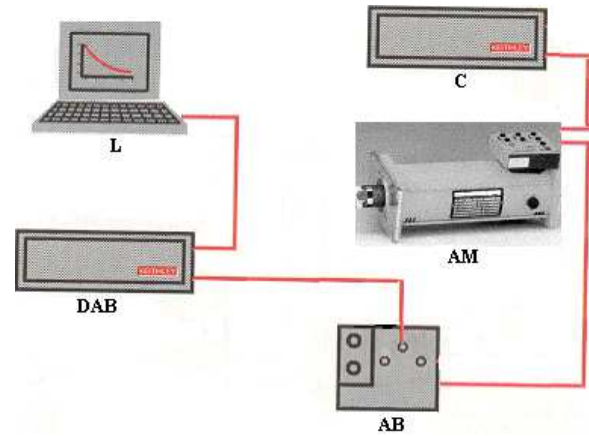


Figure 8. Scheme of assembly.

5. Tests

For carrying out the tests, a squirrel cage asynchronous motor rated at 1,2 kW has been used.

The motor has been supplied by a PWM frequency converter; its main features are detailed in [15].

Using previous experiences [12], for carrying out the measurements there has been used an external data acquisition board connected to the USB terminal of a laptop (Figure 8).

The notations used in the figure 8 are:

C – PWM converter;

AM – asynchronous motor rated at 1,2 kW;

DAB – data acquisition board [16];

L – laptop;

AB – adaptation block.

A photo of this scheme is presented in figure 9, where the elements mentioned in the previous figure can be noticed.

The adaptation of the quantities to be measured (three currents and three voltages) to the values allowed at the data acquisition board input has been achieved by a specialized block with LEM circuits (Figure 10).

This block has been conceived and achieved by the authors of this paper [13].

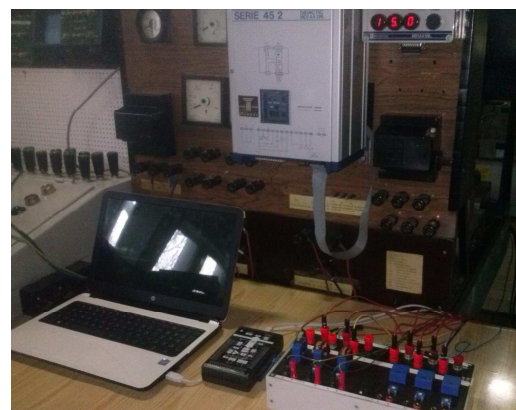


Figure 9. Photo of the experimental scheme.

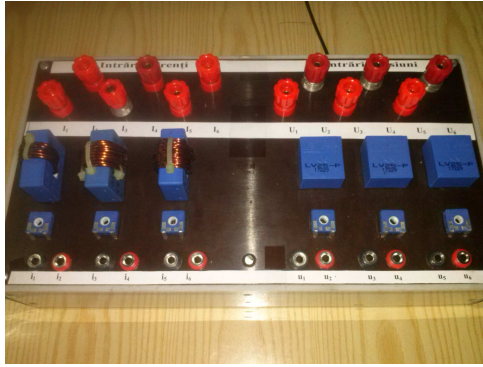


Figure 10. Adaptation block.

With the help of the scheme from figure 8 there has been established the time-dependent variation of current of phase A for case when the reference of speed has been modified by jump ($f=15$ Hz).

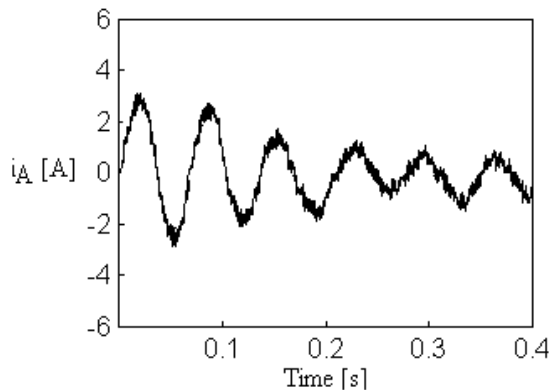


Figure 11. Experimental variation of current.

As it can be noticed, comparing the current graphic obtained experimentally (Figure 11) to the graphics obtained by simulation (Figure 5a), it results that the experiment validates the simulation, from both quantitative and qualitative point of view.

6. Conclusions

The analysis carried out in this paper has aimed at studying the influence of some parameters of asynchronous motor on the dynamic regimes obtained for the case when the supply is ensured by PWM frequency converters.

In this purpose there have been modified in turn the resistance of the rotor cage (by choosing the material it is made of) and the inertia moment (by adding a supplementary inertia weight).

The following conclusions have been obtained from the analysis of the previous graphics:

- the value of the shock current increases in case of cage made of copper;
- the duration of the transient regime of current is a little bit less in case of cage made of aluminium;
- the increase of the inertia moment leads to a strong increase of the duration of the transient regime analyzed

here without affecting the value of the shock current very much;

- the experiment confirmed qualitatively and quantitatively the time-dependent variations of the currents obtained by simulation.

It must be also emphasized that the paper presents a series of blocks built in Simulink which can be used for simulating other dynamic regimes, too.

Moreover, the data acquisition system used here has the advantage that it is mobile and it has a structure which can be easily adapted for other practical situations, too.

Acknowledgements

This work was supported by the strategic grant POSDRU/159/1.5/S/133255, Project ID 133255 (2014), co-financed by the European Social Fund within the Sectorial Operational Program Human Resources Development 2007 – 2013.

References

- [1] Benallal, M.N., Ailam, E.H., Moussa, M.A., Mahieddine, A.: Overvoltages caused by the PWM inverter in the stator coils of asynchronous motor, Electric Power Quality and Supply Reliability Conference (PQ), DOI: 10.1109/PQ.2014.6866820, 2014, pp. 243 - 246.
- [2] Contreras-Aguila, L., Garcia, N.: Stability Analyses of a VFT Park Using a Sequential Continuation Scheme and the Limit Cycle Method, IEEE Transactions on Power Delivery, Volume: 26, DOI: 10.1109/TPWRD.2010.2089703, Publication Year: 2011, pp. 1499 – 1507.
- [3] Enache, M.A.: Analysis of some basic processes specific to the operation of reluctance synchronous motor, Thesis for a doctor's degree, Craiova, 2008.
- [4] Enache, S., Vlad, I.: Induction machine – Basic notions – Dynamic processes, Ed. Universitaria, Craiova, ISBN 973-8043-122-2, 2002.
- [5] Enache, S., Campeanu, A., Vlad, I., Enache, M.A. : Influence of the filtration circuit parameters of an induction motor drive on stability, 13th International Conference on Optimization of Electrical and Electronic Equipment (OPTIM), ISBN 978-1-4673-1650-7, 2012, pp. 665 – 670.
- [6] Han, M., Kawkabani, B., Simond, J.J.: Eigenvalues analysis applied to the stability study of a variable speed pump turbine unit, 2012 XXth International Conference on Electrical Machines (ICEM), DOI: 10.1109/ICEIMach.2012.6349984, 2012, pp. 907 – 913.
- [7] Hava, A.M., Cetin, N.O.: A Generalized Scalar PWM Approach With Easy Implementation Features for Three-Phase, Three-Wire Voltage-Source Inverters, IEEE Transactions on Power Electronics, Volume: 26, Issue: 5, 2011, DOI: 10.1109/TPEL.2010.2081689, pp. 1385 – 1395.
- [8] Ivanov, S.: Performant driving systems with asynchronous motor and performant static converters, Thesis for a doctor's degree, Craiova, 1997.

- [9] Meiyang, Z., Hui G.: Integrative modeling and simulation analysis of asynchronous motor and control system, 2011 International Conference on Electrical Machines and Systems (ICEMS), Digital Object Identifier: 10.1109/ICEMS.2011.6073845, 2011, pp. 1 – 6.
- [10] Niguchi, N., Hirata, K.: Torque-Speed Characteristics Analysis of a Magnetic-Geared Motor Using Finite Element Method Coupled With Vector Control. IEEE Transactions on Magnetics, Vol. 49, Issue 5, DOI: 10.1109/TMAG.2013.2239271, 2013, pp. 2401 – 2404.
- [11] Saman, M., Karaköse, M., Akin, E.: Grey system based on flux estimation for vector control of asynchronous motors, 2011 IEEE 19th Conference on Signal Processing and Communications Applications (SIU), 2011, pp. 666 – 669.
- [12] Subtirelu, G.E., Dobriceanu, M., Enache, M.A.: Pulse and Transition Measurements in Dynamic Regimes of Electrical Motors, Annals of the University of Craiova, Year 38, No. 38, ISSN 1842 - 4805, 2014, pp. 221-228.
- [13] Vlad, I., Enache, S., Enache, M.A.: Aspects Regarding Operation Characteristics of Brush-less Direct Current Motors, Journal of Electrical and Electronic Engineering, Vol. 2, No. 2, 2014, DOI: 10.11648/j.jeee.20140202.12, pp. 41-46.
- [14] Vlad, I., Campeanu, A., Enache, S., Enache, M. A.: Energetic Aspects and Monitoring of Asynchronous Motors Starting, Proceedings of the International Conference on Optimization of Electrical and Electronic Equipment OPTIM 2014, Brasov/Cheile Gradistei, May 22-24, ISSN 1453-7397, 2014, pp. 1-6.
- [15] <http://www.unisgroup.co.uk/pdf/Telemecanique-Altivar-5-1.1-to-110-kW-User-Manual.pdf>.
- [16] <http://www.distek.ro/ro/Produs/Modul-achizitie-USB-8-canale-50kSa-s-Keithley-KUSB-3100-911>.