

---

# The Industrial Temperature Measurement System Based on the Uncooled IRFPA Detector

Chen Mingwu<sup>1</sup>, Wu Haibin<sup>2</sup>

<sup>1</sup>Department of the Computer, Anhui Post and Telecommunication College, Hefei, china

<sup>2</sup>Physics and Materials Science College, Anhui University, Hefei, China

## Email address:

chen013030209@126.com (Chen Mingwu)

## To cite this article:

Chen Mingwu, Wu Haibin. The Industrial Temperature Measurement System Based on the Uncooled IRFPA Detector. *Advances in Networks*. Vol. 7, No. 1, 2019, pp. 1-7. doi: 10.11648/j.net.20190701.11

**Received:** November 14, 2018; **Accepted:** December 13, 2018; **Published:** January 19, 2019

---

**Abstract:** Most of the non-contact temperature measuring devices in the market are mainly based on dot infrared thermometers. The single machine operated instruments can only meet the requirements of temperature measurement for local temperature points, and can not feedback the temperature information and temperature direction of the whole temperature field in real time. Under the condition of low temperature, for the Commonly non-contact temperature measurement system, the reaction is not sensitive, can not keep up with the temperature change, Continuous calibration and debugging are needed in the case of changing ambient temperature, resulting in a great waste of personnel and time. In the aspect of infrared detector, the operating wavelength of the traditional infrared CCD is 0.4-1.1 $\mu\text{m}$ , affected by the cut-off wavelength, the error of infrared CCD is very large in industrial low temperature measurement. The operating wavelength of uncooled focal plane array infrared camera is generally between 8-14 $\mu\text{m}$ , which temperature measurement accuracy can reach 0.01 $^{\circ}\text{C}$  under the optimum working environment. The UL01011 is most commonly used as the core photo detector in the uncooled focal plane uncooled micro-bolometer array infrared camera, we used it as the experimental photoelectric detector, Experiments showed that this method could achieve better results in practice.

**Keywords:** Uncooled IRFPA Camera, Infrared Thermal Imager, Microbolometer, Colorimetric Temperature Measurement, Temperature Control Network

---

## 1. Introduction

The traditional temperature measurement method is mostly contact temperature measurement. The contact temperature measurement is generally to add a heating couple to a specific temperature point to be measured. The temperature of the point is measured by a thermocouple. Contact temperature measurement can only measure local temperature, and it can not reflect the temperature situation of the entire temperature field, and contact temperature measurement can only monitor the temperature of industrial equipment such as high temperature heating furnaces. It is difficult to measure the temperature of industrial products such as steel plates and Silicon rods that are being processed inside. in addition, the service life of contact temperature measuring devices such as thermocouples in high temperature environments is very short. A steel plant can spend more than 10 million yuan on the purchase of thermocouples

each year. When replacing thermocouples, it also needs to close the furnace. This reduces production efficiency and increases production costs. For non-contact temperature measurement, most of the common non-contact temperature measurement devices on the market are mainly point-type infrared thermometer, This single-machine instrument can only meet the temperature measurement requirements for local temperature points and can not feed back temperature information and temperature trends of the entire temperature field in real time. Therefore, it is necessary to develop the non-contact temperature measuring system for real time, accurate, high temperature, high stability and large field of view. The non-contact furnace temperature measurement system mainly adopts infrared CCD, and its working wavelength is mostly 0.4-1.1 $\mu\text{m}$ , which is affected by the cutoff wavelength. [1] The infrared CCD has a small temperature measurement range and large error in the industry. The normal uncooled IRFPA camera has a working wavelength of 8-14 $\mu\text{m}$ , but its working

environment is very demanding. It needs to work in a constant temperature environment. The electron accumulation is easy to be saturated during the working process. Conventional photoelectric detectors have a very small temperature range and can not keep up with temperature changes. They are prone to temperature drift and can not meet actual needs. The InGaAs camera has a large working temperature range, high sensitivity, strong controllability, large temperature measurement range and high temperature measurement accuracy, which can meet the actual needs. In this paper, an InGaAs camera is used as an experimental photodetector. [2] In this paper, the InGaAs camera is used as an experimental photodetector.

## 2. Temperature Control System of Uncooled IRFPA Infrared Thermal Imager

The Uncooled IRFPA infrared thermal imager does not require traditional chillers and scanners. It uses thermoelectric cooling to cool photoelectric detectors. The temperature control network of the built-in thermoelectric refrigerator can effectively regulate the operating temperature of the infrared focal plane array. The temperature control system of UL01011 non-refrigeration micrometer is divided into TEC, error amplifier circuit and temperature compensation network. Its structure is shown in Figure1:

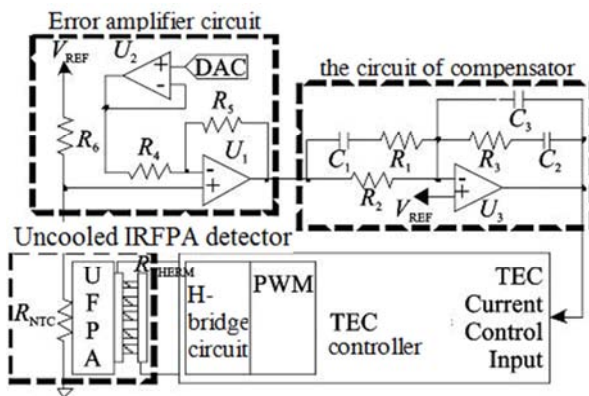

Figure 1. The temperature control network schematic.

The input of the control system is fed back by the infrared detector to the focal plane, and the control system processes the feedback information, From which to make corresponding, And affect the focal plane, Therefore, the temperature control system of the Uncooled IRFPA is a cycle system in which the parts interact with each other. The temperature control network of the Uncooled IRFPA includes a semiconductor refrigerator (TEC) and a temperature sensor (NTC). TEC is the core component of the hot spot cooling and can change the power according to the environment, so that the ambient temperature of the focal plane array is always float up and down, NTC feeds back to TEC in real time the instantaneous temperature of the Uncooled IRFPA array [3].

The temperature control system of the Uncooled IRFPA infrared thermal imager designed by PID network has the

characteristics of adjustable temperature, sensitive temperature control and high stability of the system. The temperature control system of the PID control network will monitor and cool the operating temperature of the infrared focal plane array in real time. At the same time, it will cooperate with the outside cooling methods such as air cooling and water cooling of the temperature measurement system to ensure that the infrared focal plane array works within the optimal working temperature range. It avoids the drift of thermal imager due to the high temperature in the working environment, ensures the temperature measurement accuracy of non-refrigeration infrared focal plane thermal imager, and expands the application of non-refrigeration infrared focal plane thermal imager in the field of infrared temperature measurement. [4]

## 3. Related Parameters of InGaAs Detector

The InGaAs detector has a large circular photosensitive surface with a diameter of 1mm-3mm, which is used in test instruments and photoelectric sensing systems in the wavelength range of 500nm-1700nm [5]. Ultra-low undercurrent and high dynamic impedance occupy an absolute performance advantage.

Its maximum absolute rating is shown in Figure 2:

parameter	unit	Minimum value	Maximum
The scope of work	℃	-20	+85
Storage range	℃	-40	+85
Reverse voltage	volts	---	-20
Reverse current	mA	---	10
Forward current	mA	---	20

Figure 2. The absolute maximum rating schematic.

Based on advanced indium phosphide wafers, the InGaAs camera chip provides a wide range of PIN wafers with 1mm, 2mm and 3mm photosensitive areas. Using a combination of silicon and indium potassium arsenic materials, the short-wavelength extended (500-1700nm) series of wafers can cover the visible range. Due to its low junction capacitance and large parallel resistance, it has high response speed and low noise. The corresponding bands are shown in Figure3:



Figure 3. The wavelength response range schematic.

### 4. Composition of the Temperature Measurement System

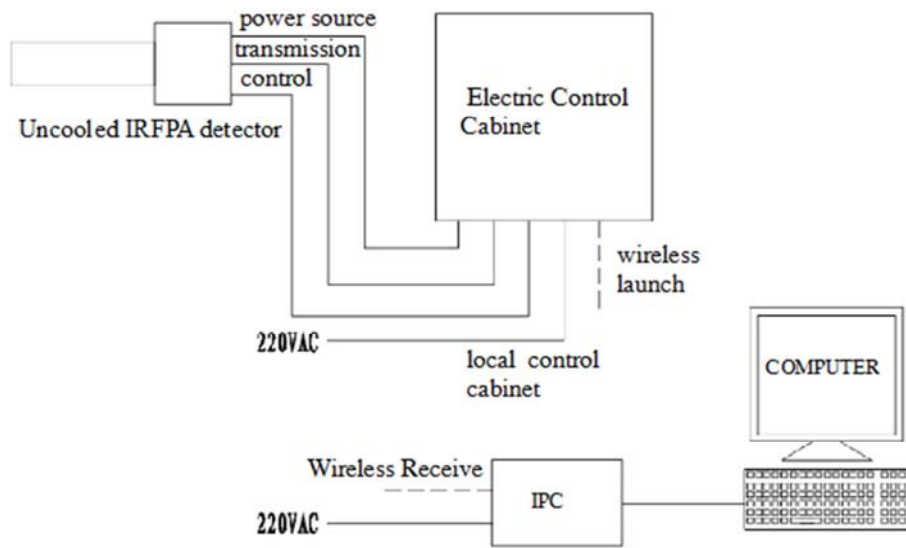

Figure 4. The system configuration.

The important parts of the industrial temperature measurement system are as follows: (1) Uncooled IRFPA detector; (2) Propulsion (including electric or pneumatic); (3) furnace wall connectors; (4) electrical control cabinets; (5) Industrial computer

#### 4.1. Workflow of the Temperature Measurement System

Filter switching device can quickly switch between two narrow band filters, so that the infrared thermal imager of the non-cooled focal plane can obtain video images of these two wavelengths in a short time [6]. The capture card collects the video image of the thermal imager and transmits it to the image processing system. The image processing system of the industrial computer divides, filters, smoothes, transforms, and enhances the

image. Finally, the T-R (T) database is called to determine the temperature of this point based on the gray ratio of the two images at the same point. Monitor output temperature measurement data and temperature field image, complete the temperature measurement. The system encodes the field of view image in pseudo-color, and the display interface can display the original image and the corresponding pseudo-color image at the same time. The staff can use the mouse to draw points and lines on the pseudo-color image. At this point, the computer's display will show all the real-time temperatures that have been crossed. [7] The output of the results is more intuitive and can help the staff to predict the temperature direction of the temperature field in the blast furnace in advance and make an early warning of excessive temperature.

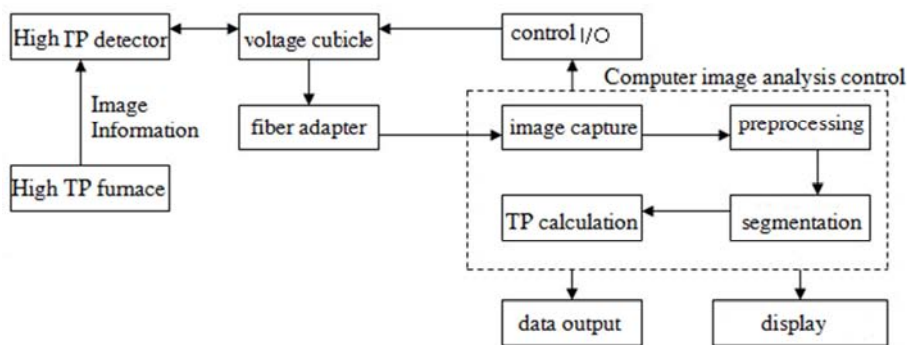

Figure 5. The Temperature measurement system workflow.

#### 4.2. Software Design Process for the System

In order to complete real-time and accurate temperature measurements and display the measurement results more

intuitively, [8] the software design flow of the Uncooled IRFPA colorimetric temperature measurement system is as follows:

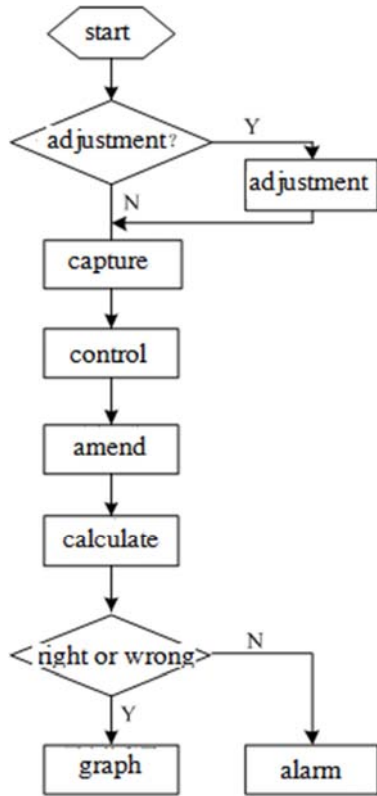

Figure 6. The system software processes.

### 5. Output of data

According to the colorimetric formula

$$T = \frac{c_2 \left( \frac{1}{\lambda_2} - \frac{1}{\lambda_1} \right)}{\ln \frac{M(T, \lambda_1) - \ln \frac{\varepsilon(T, \lambda_1)}{\varepsilon(T, \lambda_2)} - 5 \ln \frac{\lambda_2}{\lambda_1}}{\varepsilon(T, \lambda_2)}}, \text{ if } \frac{\partial \varepsilon(T, \lambda)}{\partial \lambda} = 0$$

Calculate the gray scale of double wave length after image processing, we can get the temperature

$$T = \frac{c_2 \left( \frac{1}{\lambda_2} - \frac{1}{\lambda_1} \right)}{\ln \frac{M(T, \lambda_1) - 5 \ln \frac{\lambda_2}{\lambda_1}}{M(T, \lambda_2)}}, \text{ This is the calculation formula of}$$

the colorimetric method. [9] In the field of view to be monitored, a number of key monitoring areas will be manually selected. [10]

Figures (7-8) are temperature monitoring charts of the furnace tube in a petrochemical Coke oven, The picture on the left shows a fake color tube, Nine monitoring points were set up on its surface, and users could see the real-time temperature of the nine monitoring points at the same time. [11] At the same time, other temperature points or lines that you want to monitor can also be selected by clicking or underlining to measure the real-time temperature in the temperature area to be measured online [12].



Figure 7. The temperature-line monitoring of the furnace in coking furnace.

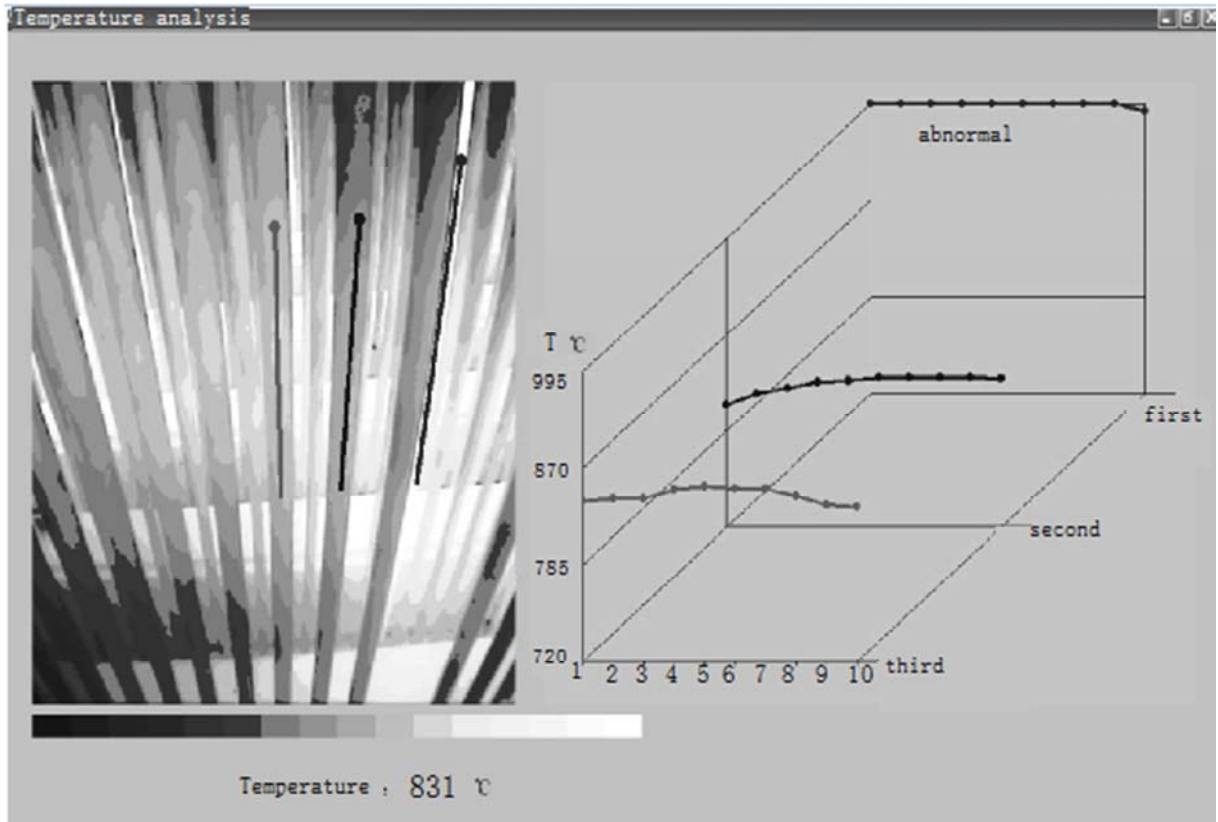

Figure 8. The temperature curve of the furnace marked lines.

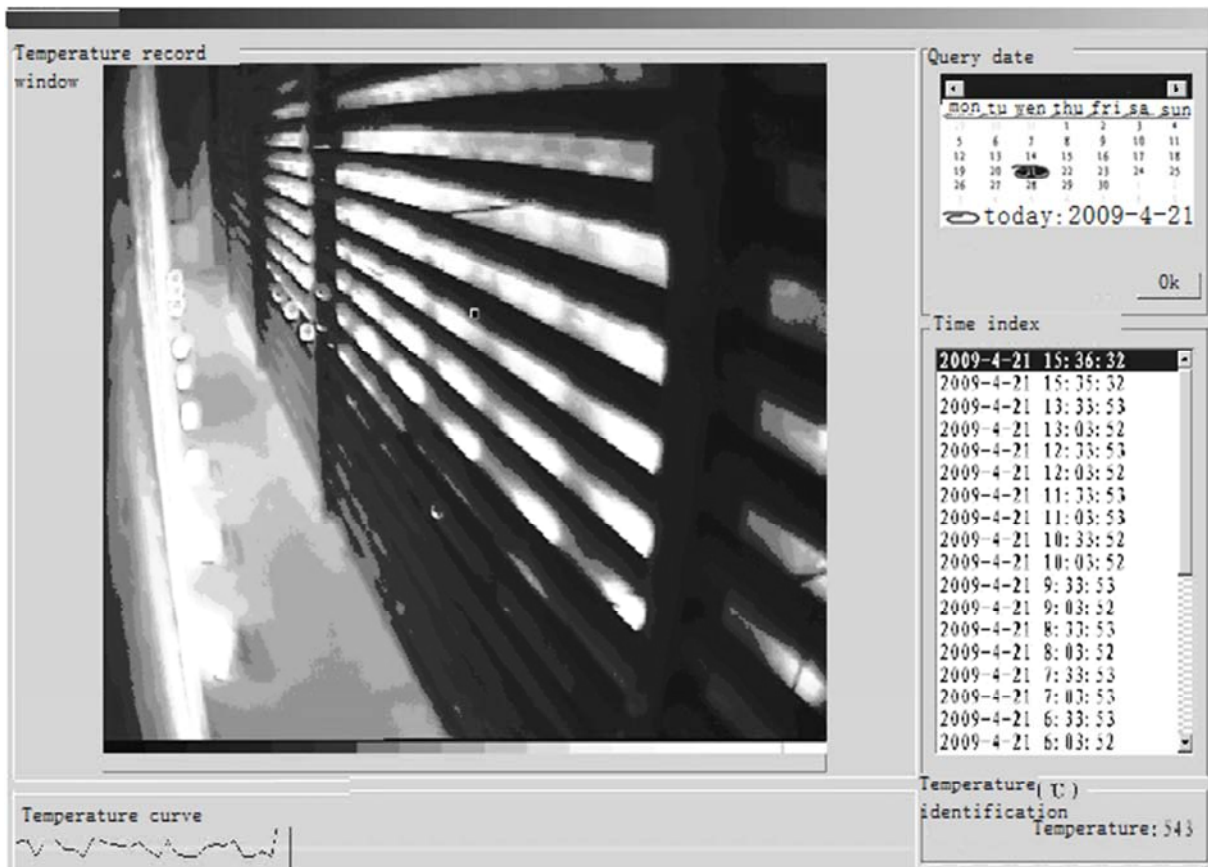

Figure 9. The historical temperature curve of the furnace marked points.

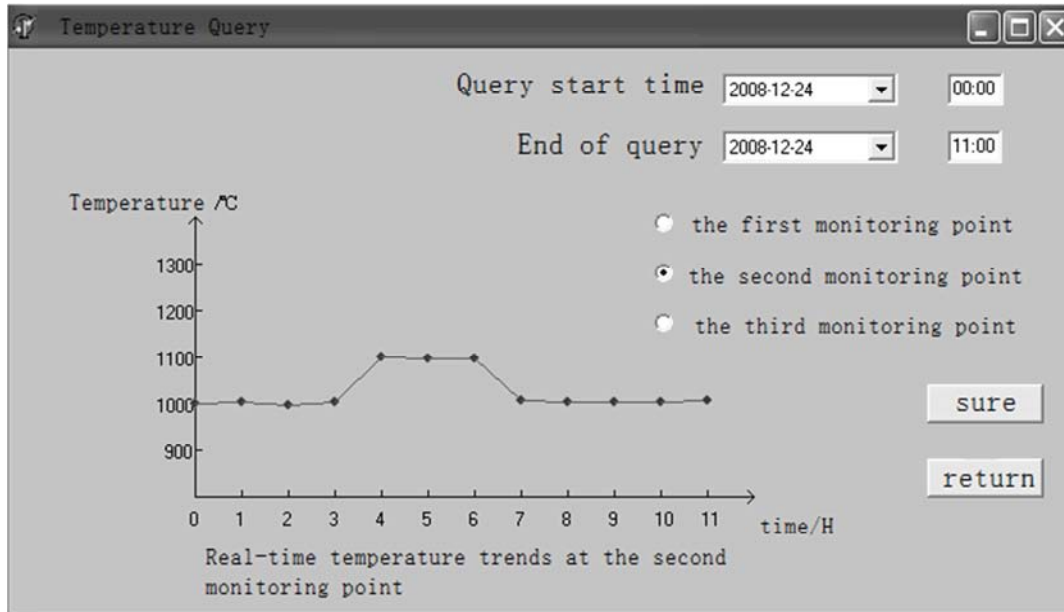

Figure 10. Query the database to get the screenshot.

In the Figures (9-10), users can use the system's database to query the historical temperature curves and the average temperature of a point on the furnace tube in recent hours or days. [13] This can more intuitively determine the temperature direction of the marking point, thus optimizing the heating plan, reducing fuel waste, and making early warnings of excessive combustion, eliminating safety hazards. [14]

## 6. Conclusion

This paper mainly introduces the hardware composition, workflow and software design flow of the contactless colorimetric temperature measurement system using the Uncooled IRFPA infrared thermal imager as the infrared detector and the display scheme of the workpiece surface temperature image. [15] The system can carry out high-precision temperature measurement of the lower temperature industrial controls, and solve the problem that the traditional non-contact temperature measurement technology is insensitive to the low temperature part and the temperature measurement accuracy is not high. The experimental results completely meet the realistic requirements. Latest research results: large-scale, Internet-based temperature measurement systems have been designed and put into use. we are satisfied with the Experimental results.

## References

- [1] Anselmi-Tamburini U, et al. A Two-color Spatial-Scanning Pyrometer for the Determination of Temperature Profiles in Combustion Synthesis Reaction [J]. *Rev. Scientific Instruments*, 1995, 66(10): 5006-5014.
- [2] Jiang Xue-dong, Wei Sui, Wu Hai-bin. The Application of Image Processing in Measurement of Furnace's Flame Temperature Field [J]. *Tiny Machine Development*, 2002, 1005-3751.
- [3] Jiang Min, Shen Wei, Zhang Zeng-jie. A new temperature compensation method for image drift of uncooled focal plane array [J]. *Infrared Technology*, 2007, 29(6): 2-4.
- [4] Liu Chun-hong, WANG Peng et al. Study on Temperature Range Expansion of Uncooled Focal Plane Thermal Imaging Camera [J]. *Journal of Atmospheric and Environmental Optics*, 2011, 6(5): 398-342.
- [5] Liu Chun-hong, Wang Peng et al. Study on the Influence of Bandwidth on Measurement Error in Colorimetric Temperature Measurement Theory [J], *Journal of Atmospheric and Environmental Optics*, 2011, Vol. 6 No. 3, 240-242.
- [6] Han Dan-fu, Wu Qing-biao. Numerical computing methods [M]. Zhe Jiang University press. 2006. 6.
- [7] Wu Hai-bin, Liu Chun-hong. Study on Error Correction Function in Colorimetric Temperature Measurement Theory [J]. *Chinese Journal of Quantum Electronics*, 2008, 20(4): 510-514.
- [8] Liu Chun-hong, Wu Hai-bin; Study on the method of reducing external environmental error in colorimetric temperature measurement [J], *Journal of Atmospheric and Environmental Optics*, 2014, 9(6): 471-475.
- [9] Liu Chun-hong. Study on the temperature detection system of workpiece surface in furnace based on near-infrared colorimetric temperature measurement technology [D]. Hefei: Anhui University, 2008.
- [10] An Yu-ying, Liu Ji-fang, Li Qing-hui. Photoelectron technique [M]. BeiJing: Electronics industry press, 2002.
- [11] Peng Xiao-qi, Zhou Hai-ye, Song Hai-ying. Interpolation correction method for CCD three-color temperature measurement [J]. *Proceedings of the CSEE*, 2004(8): 166-169.
- [12] Wu Hai-bin, Chen Jun, Zhang Jie, Zeng Wei. Selection of two-color wavelengths and minimum bandwidth calculation of filters in colorimetric temperature measurement [J]. *Quantum Electronics College Journal*. 2006 (4).

- [13] Lin Cheng-sen. Numerical Analysis [M]. Beijing: Science Press, 2006.
- [14] Han Dan-fu, Wu Qing-biao. Numerical calculation method [M]. Zhejiang University Press, 2006. 6.
- [15] Zhang Qin, Wu Hai-bin et al. Optimization of Temperature Measurement Image in Median Filtering Focusing Furnace [J]. Radio and television equipment and technology, 2010, 1: 35.

## Biography



**Chen Mingwu**, master's degree, lecturer, Department of the computer, Anhui post and telecommunication college, engaged in the teaching and research of temperature measurement, computer network, Video surveillance, Integrated cabling.