

Implementation of Distributed Fuzzy Load Control to an Autonomous Wind Diesel System

Hla Myo Tun¹, Zaw Min Naing², Win Khaing Moe², Maung Maung Latt³

¹Department of Electronic Engineering, Yangon Technological University, Yangon, Republic of the Union of Myanmar

²Department of Electrical and Electronic Engineering, Institute of Research and Innovation, Yangon, Republic of the Union of Myanmar

³Department of Electronic Engineering, Technological University (Taungoo), Taungoo, Republic of the Union of Myanmar

Email address:

hlamyotun@ytu.edu.mm (H. M. Tun), drzaw290615@gmail.com (Z. M. Naing), mgmglatt2020@gmail.com (M. M. Latt), winkmoe@gmail.com (W. K. Moe)

To cite this article:

Hla Myo Tun, Zaw Min Naing, Win Khaing Moe, Maung Maung Latt. Implementation of Distributed Fuzzy Load Control to an Autonomous Wind Diesel System. *Science Journal of Energy Engineering*. Vol. 6, No. 1, 2018, pp. 18-26. doi: 10.11648/j.sjee.20180601.13

Received: February 16, 2018; **Accepted:** March 7, 2018; **Published:** April 12, 2018

Abstract: Many autonomous power systems are powered by diesel generators alone, which results in greater operating costs than interconnected grids. It is therefore desirable to integrate renewable energy sources such as wind into these mini grids. However, due to the fluctuating power generation from the wind resource, the varying load profile and the relatively low system inertia, technical difficulties arise in terms of system stability and efficient operation. Typically the penetration of wind energy on such systems is limited to 30%. Distributed intelligent load control can be used to increase wind penetration and cut diesel fuel consumption, whilst maintaining system stability. This thesis describes the development and application of a distributed intelligent load control system. The development of a self-tuning fuzzy controller and the construction of a laboratory wind-diesel test rig are discussed. The development of a dynamic Wind-Diesel computer model is also described. Finally the results of tests carried out on a Wind-Diesel system consisting of a 45kW stall regulated wind turbine and a 48kW diesel generator are discussed. The results were encouraging demonstrating that distributed fuzzy load control is a low cost and effective technique, which can be applied to small or large hybrid systems. The simulation results are developed by MATLAB.

Keywords: Distributed Fuzzy Load Control, Autonomous Wind Diesel System, Hybrid System, MATLAB, Energy Engineering

1. Introduction

In the majority of the world's poorer countries it is estimated that significantly less than 5% of the rural population is connected to the national grid. Provision of electricity to some of these rural communities can help to alleviate poverty. Grid connection is often not technically or economically viable in these remote areas and therefore stand alone diesel generators are predominantly used to provide electricity. Diesel generators are relatively cheap and reliable however the fuel is polluting and expensive, especially when transport costs are taken into account. The integration of renewable energy sources into these systems is therefore attractive but brings technical challenges with it.

Autonomous systems have relatively low inertia, and more unpredictable load and generation profiles than grid connected

systems. Therefore they can suffer from frequent blackouts and instabilities in frequency and voltage. Fast acting governors for these generators are not economical on systems of this size and therefore other methods to maintain stability have been explored. Energy storage can be used in an attempt to ride through periods of generation deficit. An effective load control system can manipulate time deferrable loads such that stable integration of renewable energy sources can be achieved. A major problem for wind-diesel systems is that of low wind power penetration. Load control can shed nonessential loads momentarily to allow the power system to ride through lulls in wind speed thus avoiding starting the diesel engine. This can result in significant diesel fuel savings. This thesis describes the development and testing of an intelligent load control system.

Autonomous renewable energy systems often suffer from frequency instability due to instantaneous imbalances between

the power being generated by the system and the power being consumed by the loads on the system. The following equation shows the basic relationship affecting frequency on a wind-diesel network.

2. Analytical Model of Wind Diesel System

The analytical model of a wind/diesel system, following the example of an earlier screening model is designed to be applied over periods of time when the wind resource and load are uncorrelated. In practice, this is the case for seasonal or monthly case studies. Thus, a complete year can be comprised of a number of model runs. The following summary presents

an overview of the basic subcomponent model assumptions, input requirements (preliminary estimates or guesses can be used) and the system control/ operating strategy used for the latest version of the screening model. There are subcomponent models for wind diesel hybrid system analysis. Please submit your manuscript electronically for review as e-mail attachments. When you submit your initial full paper version, prepare it in two-column format, including figures and tables.

A wind-diesel hybrid power system with static synchronous compensator (STATCOM) considered for study is shown in Figure 1. The real and reactive power balance equations of the system under steady state conditions are given by

$$P_{IG} + P_{SG} = P_L$$

$$Q_{SG} + Q_{com} = Q_L + Q_{IG}$$

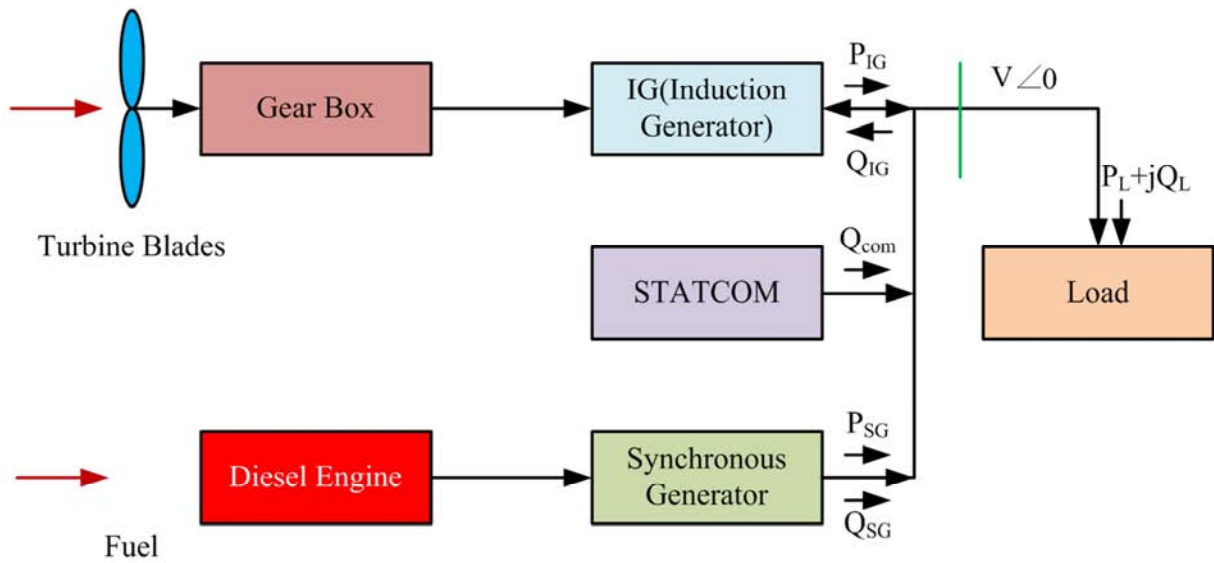

Figure 1. Single Line Diagram of the Wind-Diesel Hybrid Power System.

Due to disturbance in load reactive power ΔQ_L , the system voltage may change which results an incremental change in reactive power of other components. The net reactive power surplus is $\Delta Q_{SG} + \Delta Q_{com} - \Delta Q_L - \Delta Q_{IG}$ and it will change the system bus voltage which will govern by the following transfer function equation:

$$\Delta V(s) = \frac{K_V}{1+sT_V} [\Delta Q_{SG}(s) + \Delta Q_{com}(s) - \Delta Q_L(s) - \Delta Q_{IG}(s)]$$

where, K_V and T_V are the system gain and time constant. All the connected loads experience an increase with the increase in voltage due to load voltage characteristics as shown below

$$D_V = \frac{\partial Q_L}{\partial V}$$

The composite loads can be expressed in exponential voltage form as

$$Q_L = c_1 V^Q$$

The load voltage characteristics D_V can be found empirically as

$$D_V = \frac{\partial Q_L}{\partial V} = q \cdot \frac{Q_L^0}{V^0}$$

$K_V = 1/D_V$ and T_V is the time constant of the system which is proportional to the ratio of electromagnetic energy stored in the winding to the reactive power absorbed by the system. An IEEE type-1 excitation control system as shown in Figure 2 is considered for the synchronous generator of the hybrid system with saturation neglected, therefore the state transfer equations are

$$\Delta E_{fd}(s) = \frac{1}{K_E + sT_E} \Delta V_o(s)$$

$$\Delta V_o(s) = \frac{K_A}{1+sT_A} (-\Delta V(s) - \frac{K_F}{T_F} \Delta E_{fd}(s) + \Delta V_f(s))$$

$$\Delta V_f(s) = \frac{K_F}{T_F} \cdot \frac{1}{1+sT_A} \Delta E_{fd}(s)$$

The small change in voltage behind transient reactance $\Delta E'_q(s)$ by solving the flux linkage for small perturbation is

given below

$$\Delta E'_q(s) = \frac{1}{1+sT_G} [K_1 \Delta E_{fd}(s) + K_2 \Delta V_f(s)]$$

$$K_1 = X'_d / X_d$$

$$K_2 = [(X_d - X'_d) \cos \delta] / X'_d$$

$$T_G = T'_{do} X'_d / X_d$$

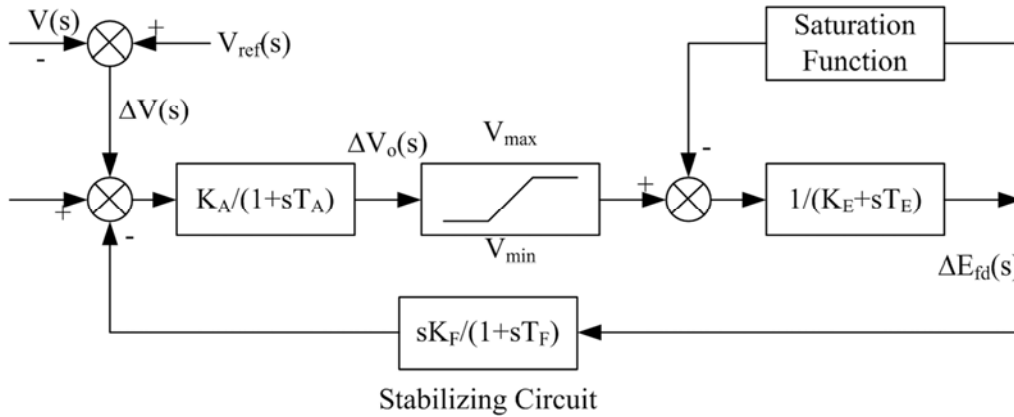

Figure 2. IEEE Type-1 Excitation Control System.

Load control attempts to minimize the frequency excursions by matching the power in the loads to that of the current power generation. Load control has been used in autonomous systems. Although these systems are successful there is considerable room for improvement.

3. Proposed Model

Wind-Diesel (W-D) hybrid systems combine wind turbines with diesel generating sets (DG sets) for electricity generation. This can either be a new WD hybrid power plant or wind turbines can be integrated with an existing diesel power plant having one or more DG sets supplying power into a de-centralized grid. The main purpose of adding wind turbines is to reduce diesel fuel consumption leading to the environmental and cost benefits associated with reducing

usage of fossil fuels. The “penetration level” of the wind power plant in a diesel electric grid is the ratio of the capacities of the wind power plant to the diesel power plant. The penetration level determines the complexity of the system. For low penetration levels (15% - 20%), standard wind electric generators (manufactured for operation connected to large mainland grids) can be connected directly to the AC bus of the diesel grid. The wind turbines have their own microprocessor based control systems and safety features, and this is sufficient to maintain grid stability (voltage and frequency). At least one DG set is kept running and energizes the grid all the time. Since the capacity factor of the wind turbines will only be around 25-30%, a low penetration of wind turbines does not lead to substantial diesel fuel savings. Figure 1 show the overall system block diagram.

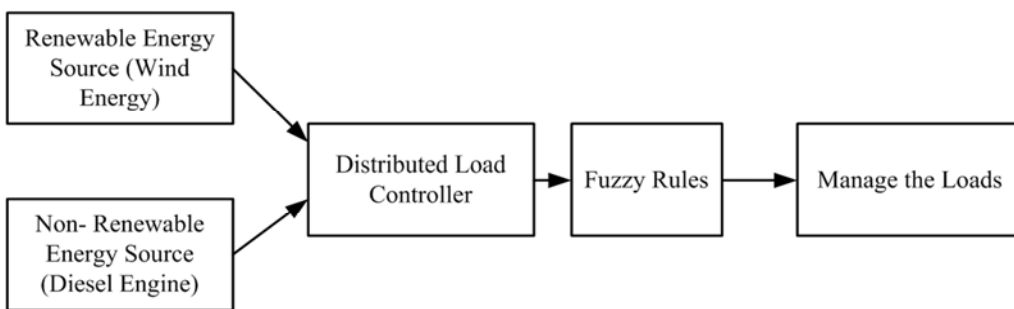

Figure 3. Overall System Block Diagram.

4. Distributed Fuzzy Load Control

Autonomous renewable energy systems such as wind powered networks experience real time variations of input energy and load, and therefore control methods are required to maintain stability and achieve maximum penetration from the wind resource. The conventional engine driven autonomous power systems use the governors for frequency control.

Autonomous renewable energy systems however may be controlled using either load control or energy storage. Energy storage schemes utilizing batteries, flywheels, and hydraulic accumulators have all been considered for frequency control but can be rather expensive and complex to control. A load control system was developed to provide an improved, energy efficient, frequency control solution. The system employs a number of low cost microcontroller based devices distributed around the system. Each device has a designated single phase

load it can control. The devices have no communication facilities. Software embedded in the micro-controllers measure the frequency and voltage of the power system and this information is used to make load switching decisions. Figure 4 illustrates a typical mini grid and how the load controllers may be connected. The measurement algorithms use a level crossing detection algorithm that avoids erroneous frequency estimates sometimes caused by false zero crossings in the voltage waveform due to distortion. The load controllers must be able to react quickly to changes in system frequency especially with wind powered networks. The power generated by a wind turbine is proportional to the cube of the wind speed.

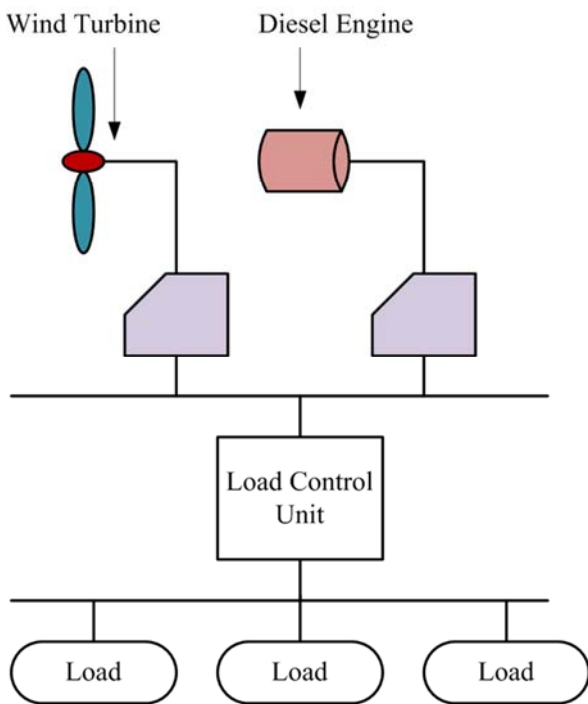

Figure 4. Mini Grid with Load Controllers.

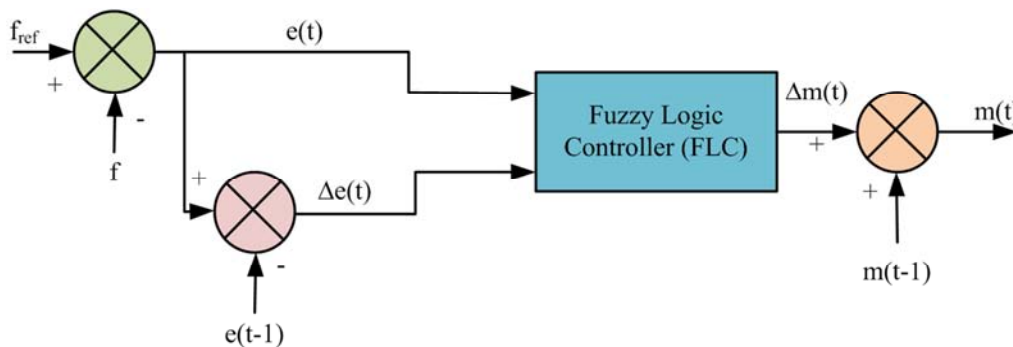

Figure 5. Block Diagram of the FLC.

The membership functions were defined off-line, and the values of the variables are selected according to the behavior of the variables observed during simulations. The selected fuzzy sets for FLC are shown in Figure 8. The control rules of the FLC are represented by a set of chosen fuzzy rules. The designed fuzzy rules used in this work are given in Table 1.

Therefore even small change in wind speed has a large effect on the power generated by the wind turbine. Distributed load control is used which offers benefits over traditional centralized systems, as it is naturally robust. This is because if one load controller fails or is disconnected, the rest of the system can continue to function adequately. Also the distributed nature permits a finer level of control.

The fuzzy controllers share a single target frequency and therefore do not require a complex set up procedure and also distribute the available energy equitably among consumers. The fuzzy load controllers are designed to be used primarily with resistive loads such as space and water heaters.

5. Implementation

For a good performance of HPNSWD system, the fuzzy logic controller is used. The FLC controller is replaced by the PID to control the frequency. In the FLC, The reference frequency f_{ref} is compared with the actual frequency f to obtain the frequency error $e(t)$ as shown in Figure 5. Also this error is compared with the previous error $e(t-1)$ to get the change in error $\Delta e(t)$. The inputs of FLC are $e(t)$ and $\Delta e(t)$. The output of the proposed controller is $\Delta m(t)$. $\Delta m(t)$ is added to the previous state $m(t-1)$ to get the output signal $m(t)$. This output signal is converted to an 8-bit digital signal controlling switching of the eight three-phase secondary loads.

Table 1. The Rules of Fuzzy Logic Controller.

		e						
		NL	NM	NS	ZR	PS	PM	PL
Δe	NL	PL	PL	PM	PM	PS	PS	ZR
	NM	PL	PM	PM	PS	PS	ZR	NS
	NS	PM	PM	PS	PS	ZR	NS	NS
	ZR	PM	PS	PS	ZR	NS	NS	NM
	PS	PS	PS	ZR	NS	NS	NM	NM
	PM	PS	ZR	NS	NS	NM	NM	NL
	PL	ZR	NS	NS	NM	NM	NL	NL

The fuzzy sets have been defined as: NL, negative large, NM, negative medium, NS, negative small, ZR, zero, PS, positive small, PM, positive medium and PL, positive large respectively. According to the above Table 1, there are forty-nine rules to implement the fuzzy logic controller for wind diesel system. The mf 1 to 7 refers to membership

function 1 to 7 or NL, NM, NS, ZR, PS, PM, and PL. They are as follows:

- If (Wind is NL) and (Diesel is NL) then (Load Control is PL)
- If (Wind is NL) and (Diesel is NM) then (Load Control is PL)
- If (Wind is NL) and (Diesel is NS) then (Load Control is PM)
- If (Wind is NL) and (Diesel is ZR) then (Load Control is PM)
- If (Wind is NL) and (Diesel is PS) then (Load Control is PS)
- If (Wind is NL) and (Diesel is PM) then (Load Control is PS)
- If (Wind is NL) and (Diesel is PL) then (Load Control is ZR)
- If (Wind is NM) and (Diesel is NL) then (Load Control is PL)
- If (Wind is NM) and (Diesel is NM) then (Load Control is PM)
- If (Wind is NM) and (Diesel is NS) then (Load Control is PM)
- If (Wind is NM) and (Diesel is ZR) then (Load Control is PS)
- If (Wind is NM) and (Diesel is PS) then (Load Control is PS)
- If (Wind is NM) and (Diesel is PM) then (Load Control is ZR)
- If (Wind is NM) and (Diesel is PL) then (Load Control is NS)
- If (Wind is NS) and (Diesel is NL) then (Load Control is PM)
- If (Wind is NS) and (Diesel is NM) then (Load Control is PM)
- If (Wind is NS) and (Diesel is NS) then (Load Control is PS)
- If (Wind is NS) and (Diesel is ZR) then (Load Control is PS)
- If (Wind is NS) and (Diesel is PS) then (Load Control is ZR)
- If (Wind is NS) and (Diesel is PM) then (Load Control is NS)
- If (Wind is NS) and (Diesel is PL) then (Load Control is NS)
- If (Wind is ZR) and (Diesel is NL) then (Load Control is PM)
- If (Wind is ZR) and (Diesel is NM) then (Load Control is PS)
- If (Wind is ZR) and (Diesel is NS) then (Load Control is PS)
- If (Wind is ZR) and (Diesel is ZR) then (Load Control is ZR)
- If (Wind is ZR) and (Diesel is PS) then (Load Control is NS)
- If (Wind is ZR) and (Diesel is PM) then (Load Control is NS)
- If (Wind is ZR) and (Diesel is PL) then (Load Control is NM)
- If (Wind is PS) and (Diesel is NL) then (Load Control is PS)
- If (Wind is PS) and (Diesel is NM) then (Load Control is PS)
- If (Wind is PS) and (Diesel is NS) then (Load Control is ZR)
- If (Wind is PS) and (Diesel is ZR) then (Load Control is NS)
- If (Wind is PS) and (Diesel is PS) then (Load Control is NS)
- If (Wind is PS) and (Diesel is PM) then (Load Control is NM)
- If (Wind is PS) and (Diesel is PL) then (Load Control is NM)
- If (Wind is PM) and (Diesel is NL) then (Load Control is PS)
- If (Wind is PM) and (Diesel is NM) then (Load Control is ZR)
- If (Wind is PM) and (Diesel is NS) then (Load Control is NS)

- If (Wind is PM) and (Diesel is ZR) then (Load Control is NS)
- If (Wind is PM) and (Diesel is PS) then (Load Control is NM)
- If (Wind is PM) and (Diesel is PM) then (Load Control is NM)
- If (Wind is PM) and (Diesel is PL) then (Load Control is NL)
- If (Wind is PL) and (Diesel is NL) then (Load Control is ZR)
- If (Wind is PL) and (Diesel is NM) then (Load Control is NS)
- If (Wind is PL) and (Diesel is NS) then (Load Control is NS)
- If (Wind is PL) and (Diesel is ZR) then (Load Control is NM)
- If (Wind is PL) and (Diesel is PS) then (Load Control is NM)
- If (Wind is PL) and (Diesel is PM) then (Load Control is NL)
- If (Wind is PL) and (Diesel is PL) then (Load Control is NL)

6. Function Creation of FLC in MATLAB

The function linking for creation of MATLAB GUI to analyze the wind diesel system is illustrated in Figure 6. The GUI main window for wind diesel system is linked with three functions such as distributed load control fuzzy inference system (FIS), the fuzzy PID controller for ΔQ_{com} Vs Time, and the fuzzy PID controller for ΔV Vs Time.

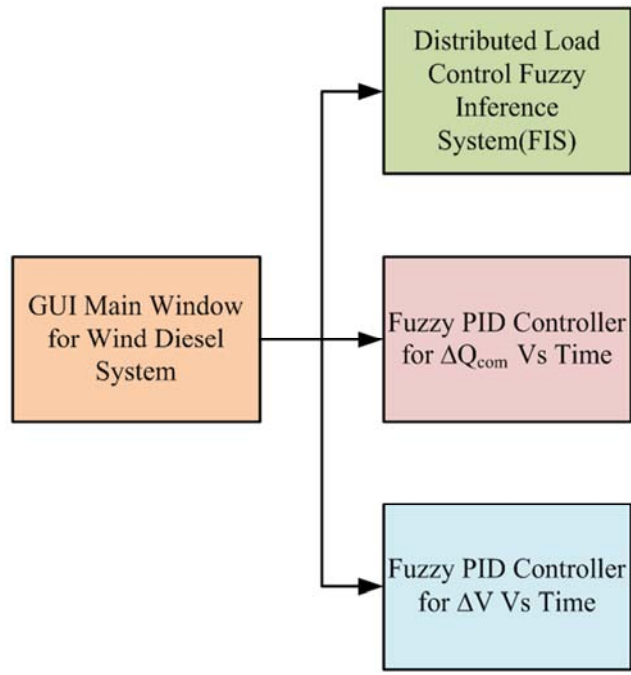

Figure 6. Function Linking for Creation of MATLAB GUI.

7. System Flowchart

The system flowchart to implement the wind diesel system is illustrated in Figure. 7.

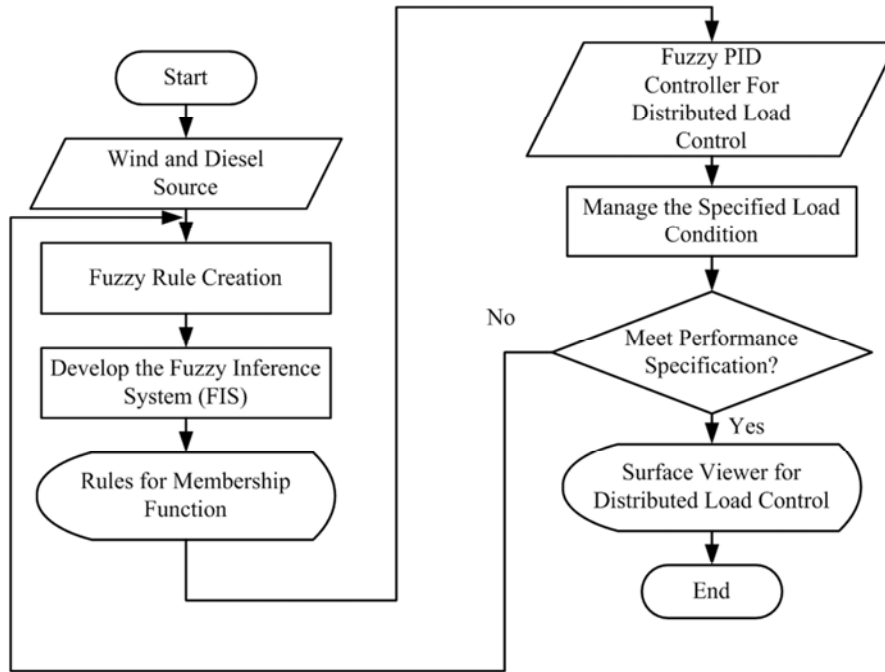

Figure 7. System Flowchart.

8. Simulation Results

In this study, the wind speed is 10 m/s such that the wind turbine produces enough power to supply the load. Here, the diesel generator is used as a synchronous condenser and its excitation system controls the grid voltage at its nominal value. The dynamic performance of the frequency control system is illustrated when an additional 25 KW customer load is switched on. For the IG mode, its speed is slightly above the synchronous speed (1.011 pu).

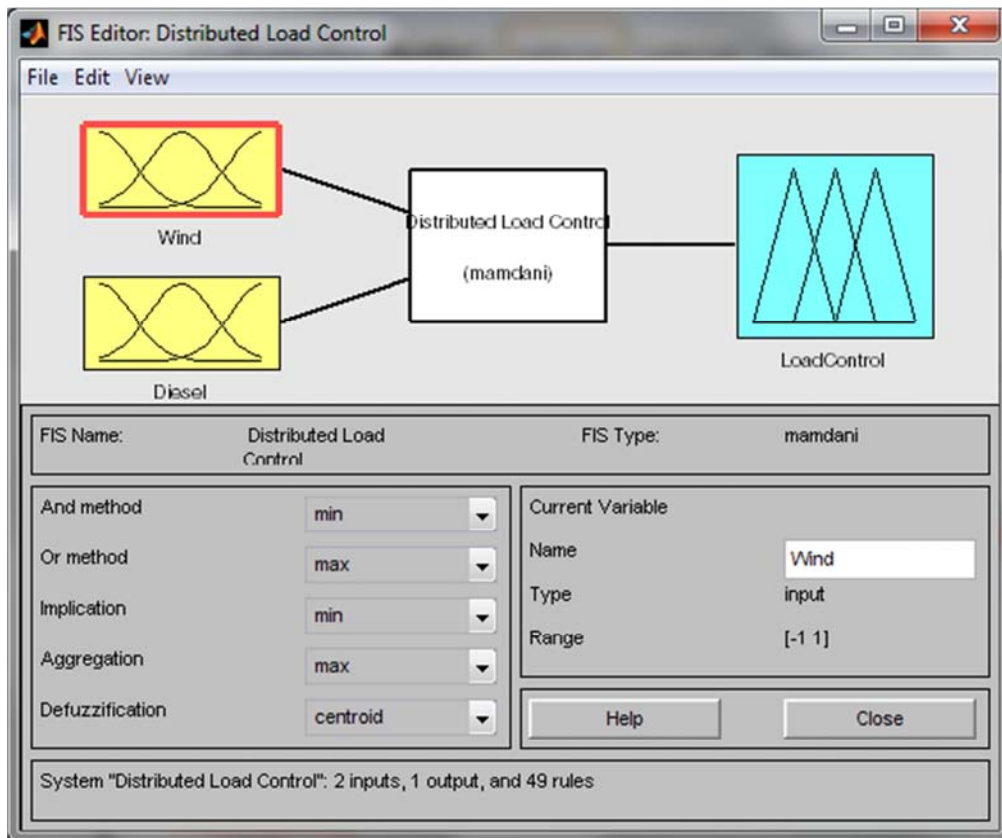

Figure 8. Import FIS Editor for Distributed Load Control.

According to the turbine characteristics, for a 10 m/s wind speed, the turbine output power is 0.75 pu (206kW). Because of the IG losses, the IG produces 200 KW. As the main load is 50 KW, the secondary load absorbs 150 KW to maintain a constant 60 Hz frequency. At $t=0.2$ s, the additional load of 25 KW is switched on. The frequency momentarily drops and the frequency controller reacts to reduce the power absorbed by the secondary load in order to bring the frequency back to 60 Hz.

The voltage stays at the rated value without any fluctuations.

The import FIS editor for Distributed Load Control is illustrated in Figure 8. There are two inputs for wind and diesel and only one output for load control to analyze the fuzzy logic controller for wind diesel system.

The membership function of wind input stage with respect to seven rules is shown in Figure 9. The red color line is for mf1 or membership function 1.

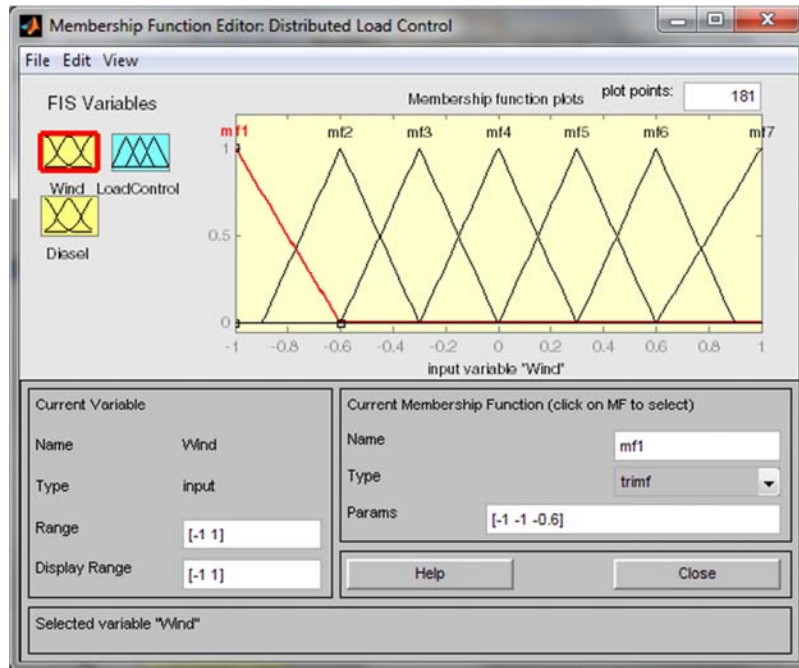

Figure 9. Membership Function of Wind Input Stage.

The rule viewer of distributed load control for power off stage is shown in Figure 10. In this stage, the value of load control is approximately zero level.

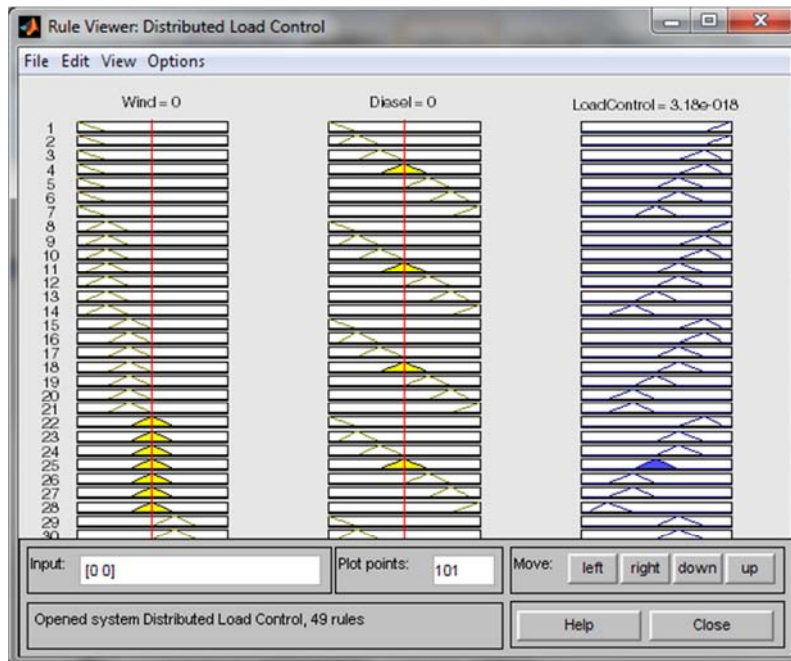

Figure 10. Rule Viewer of Distributed Load Control for Power off Stage.

The surface viewer of distributed load control for wind diesel system based on wind energy is illustrated in Figure 11.

The response of fuzzy PID controller for wind diesel system based on ΔQ_{com} Vs Time (ms) is shown in Figure 12. The value of ΔQ_{com} is stable at about 350ms.

The response of fuzzy PID controller for wind diesel system based on ΔV Vs Time (ms) is shown in Figure 13. The value of ΔV is stable at about 130ms.

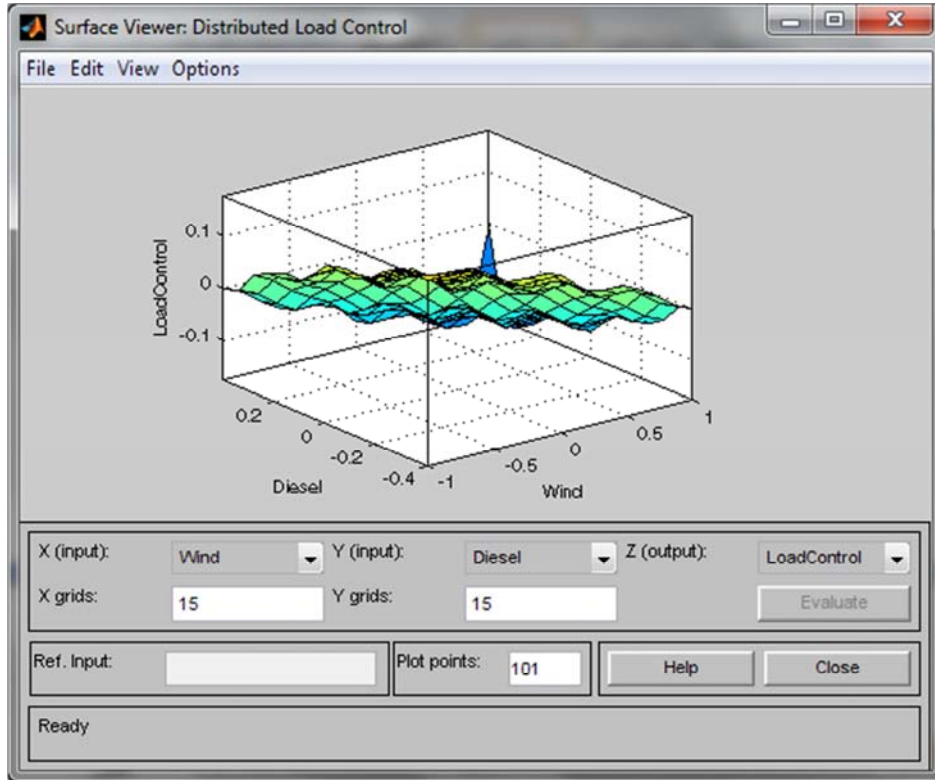

Figure 11. Surface Viewer of Distributed Load Control for Wind Diesel System Based on Wind Energy.

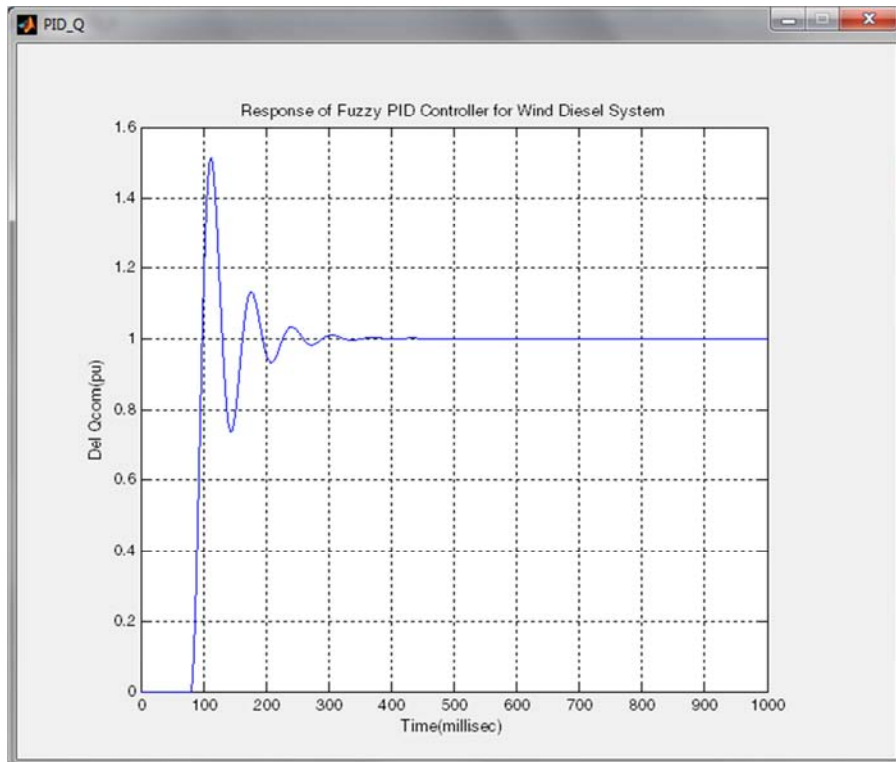

Figure 12. Response of Fuzzy PID Controller for Wind Diesel System based on ΔQ_{com} Vs Time (ms).

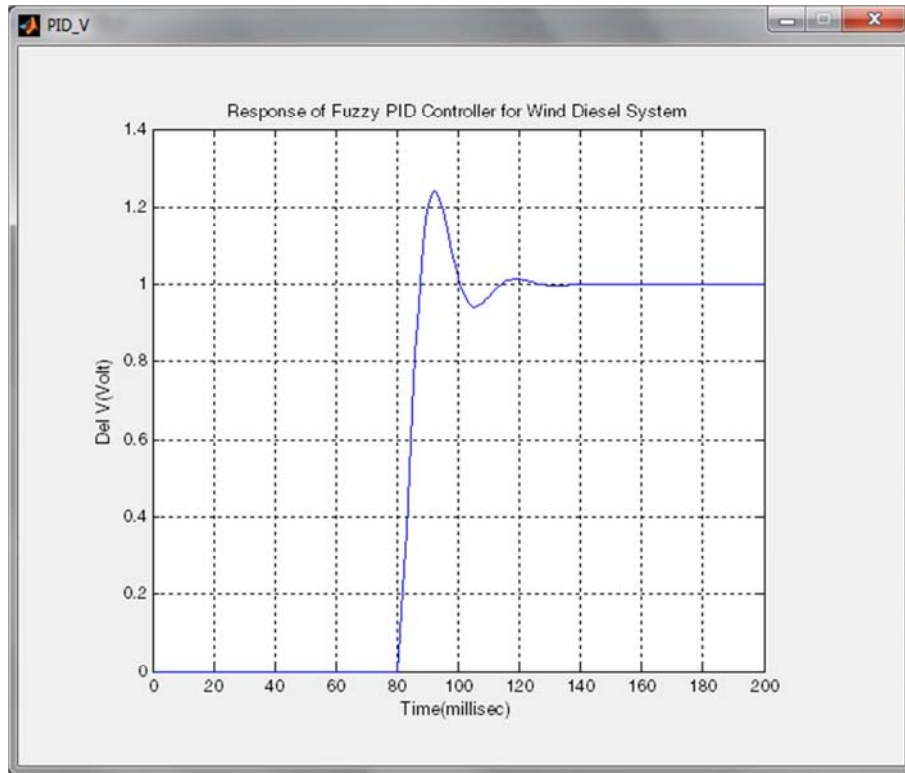

Figure 13. Response of Fuzzy PID Controller for Wind Diesel System based on ΔV Vs Time (ms).

9. Conclusion

Fuzzy controllers were successfully developed to control the wind-diesel power system frequency and voltage within the limits. This was achieved in wind power only mode with only fifteen load controllers and a single wind turbine. With more wind turbines the power fluctuations would be reduced and with more load controllers a better level of control would be expected. The site results compare well with those generated by the test rig and the computer model and therefore they represent good design tools for work on future autonomous power systems. The stable operation achieved in wind only mode is encouraging, use of these load controllers should allow a system to run for extended periods without running the diesel generator. It is therefore hoped that this equipment can be used to increase the wind power penetration of autonomous Wind–Diesel systems.

References

- [1] T. Anderson, A. Doig, D. Rees, S. Khennas, "Rural Energy Services, A Handbook for Sustainable Energy Development." Intermediate Technology Publications, London, 1999, pp 3-11.
- [2] S. K. Aditya, D. Das, "Application of Battery Energy Storage to Load Frequency Control of an Isolated Power System.", International Journal of Energy Research, 23, 1999, pp247-258.
- [3] W. M. Somerville. "Fair Isle renewed", Proceedings of the British Wind Energy Association Conference 1999, pp263-280.
- [4] Stevenson, W. G, Somerville, W. M, "Optimal use of wind and diesel generation on a remote Scottish Island", Proceedings of the European Wind Energy Association Conference 1984, Part2, pp 681-684.
- [5] P. Taylor, N. Jenkins, C. Robb. "Distributed Intelligent Load Control of Autonomous Renewable Energy Systems", Proceedings of the British Wind Energy Association Conference 1999, pp255-263.
- [6] K. Pandiaraj, P. Taylor, N. Jenkins, C. Robb. "Distributed load control of autonomous renewable energy systems", Accepted for publication by IEEE Transactions on Energy Conversion, 1999.
- [7] Y. Song, A. T. Johns, "Applications of Fuzzy Logic in Power Systems." Power Engineering Journal, October 1997, pp 219-222.