

---

# Design and Development of an Agricultural and Bio-materials Cabinet Tray Dryer

Godwin E. Akpan<sup>2</sup>, David N. Onwe<sup>1</sup>, Olugbenga A. Fakayode<sup>1</sup>, Ubong D. Offiong<sup>2</sup>

<sup>1</sup>Agricultural and Food Engineering Department, Faculty of Engineering, University of Uyo, Uyo, Nigeria

<sup>2</sup>Agricultural Engineering Department, Faculty of Engineering, Akwalbom State University, Uyo, Nigeria

## Email address:

godytex2000@yahoo.com (G. E. Akpan), davidonwe@uniuyo.edu.ng (D. N. Onwe)

## To cite this article:

Godwin E. Akpan, David N. Onwe, Olugbenga A. Fakayode, Ubong D. Offiong. Design and Development of an Agricultural and Bio-materials Cabinet Tray Dryer. *Science Research*. Vol. 4, No. 6, 2016, pp. 174-182. doi: 10.11648/j.sr.20160406.15

**Received:** October 4, 2016; **Accepted:** December 2, 2016; **Published:** February 9, 2017

---

**Abstract:** A locally made agricultural and bio-material dryer to be operated by local farmers was designed and developed to reduce Agricultural material wastage and improve their storage conditions. It consists of three units: drying chamber, blower and heat exchanger. The performance test and evaluation were conducted using analysis of variation (ANOVA) using okro, pepper and groundnut as the test materials at an average drying chamber temperature of 50°C for safe drying of the produce. The three crop, (okro, pepper and groundnut) and drying time (9hours), the kilogram weight of the crops decreased with increase in drying time as drying progressed, hence there was no significant difference at 5% level of significance in the drying rates of the three crops. The dryer which has a mean drying capacity of 60.3kg per batch with a thermal efficiency of 76.9% and drying rate of 0.041kg/hr, at relative humidity of 35% improved the drying time of the agricultural materials and is recommended for local farmers.

**Keywords:** Design, Development, Dryer, Agricultural, Bio-material, Cabinet, Tray

---

## 1. Introduction

Drying is one of the methods employed to preserve agricultural products after harvesting. Agricultural products are characterized with high initial moisture content. They have morphological features quite distinct from other natural materials that greatly influence their behavior during drying and preservation. They also consist of capillary porous structures, through which the moisture is removed during the drying process (Akulich and Militer, 1998; Kulasiri and Woodhead, 2005). The drying of agricultural materials involves simultaneous heat and mass transfers to and from materials (Murugesan *et al.*, 2002; Magaris and Ghiaus, 2007). Thus, during drying, vapor is generated throughout the material, transferred to the surface and removed by airflow at the surface. Heat is transferred to the material by conduction causing the moisture to change from liquid phase to vapour and evaporate at the surface (Johnson *et al.*, 1998).

Therefore, the drying process involves inter-phase mass transfer from the wet material to the gaseous drying agent (heated air), which may be illustrated as a transport of

moisture from material core to its surface, followed by evaporation at the surface of the material, and dissipation of water vapour into the bulk of the gaseous agent (Margaris and Ghaus, 2007).

Agriculture is the most engaged activities of Nigerian rural dwellers and the climatic condition of the Country makes the soils suitable for the profitable cultivation and production of a wide variety of grains and tubers (FAOSTAT, 2004), which are the most consumed food recipes. These grains and tubers are susceptible to large storage losses due to rodents, damp, fungi and natural decay (Agboola, 1992; Agridem, 1995). Furthermore, the grains and tubers in their unprocessed state are subject to deterioration. Thus, making studies related to drying of agricultural and bio-materials relevant.

Agricultural produce can be dried using a number of ways, such as sun drying, solar drying and natural ventilation. In sun drying, the material is spread on the ground, roof top, compacted soil, and concrete floor, under the sun. The material is occasionally turned. There are numerous disadvantages of this method such as re-absorption of moisture from the ground, uneven drying, insect and animal invasion, exposure to dirt and dust, occupies large area of land, etc.

Solar drying is done through the principle of green house effect and blowing air. The disadvantage of this method is the non availability of sun rays all round the clock (Sahay and Singh, 1996). Considering the numerous disadvantages of the above mentioned methods, a cabinet tray dryer overcomes all these disadvantages.

The dryer is made up of three sections, the energy source (electricity), blower and the drying cabinet sections. The energy source is located behind the dryer, which is used to connect the dryer to electricity source for proper functioning. The suction fan is located at the middle of the drying chamber and has a power rating of 0.2 hp. The fan helps in circulating heat for effective and efficient heat flow rate within the drying cabinet. During this period the fan helps in maintaining the temperature within the drying chamber.

The cabinet is fabricated from mild steel of 2mm thickness and the coir fibre(plant based fibre) was used as insulator to control heat loss by conduction. The drying chamber has three slots for each drying tray. The trays are perforated to effectively allow the airflow within the chamber. In line with the need to evolve a dual purpose effective cabinet tray dryer for local farmers' use in Akwa Ibom State, Nigeria with 100% locally sourced materials and components which will be cheap and readily available for local farmers usage in the state and to reduce post harvest loss, the design and development of a cabinet tray dryer (Figure 1) was done.



Figure 1. Fabricated cabinet tray dryer.

## 2. Material and Methods

Considering the environmental factor, economic factor and

availability of this dryer to local farmers to reduce post harvest loss, the materials used were sourced locally and they were selected based on the following factors; ability to withstand heat, vibration, humid air fatigue and stress without failure during operation. Electric heater and thermostat were purchased and used. However, the fabrication was then carried out based on the design calculation below.

### 2.1. Design Calculations

The design of the cabinet tray dryer was done taking the following into consideration: amount of moisture to be removed, quantity of air required to effect drying, volume of air to effect drying, suction fan design and capacity, quantity of heat required, heat transfer rate, design of power rating of the electric heating element, actual heat used to effect drying, rate of mass transfer, thermal efficiency of the dryer and drying rate. The ambient temperature, Relative Humidity (RH) and the drying chamber temperature, etc were assumed to be 31°C, 35%, 50°C respectively, tray size of 630mm x630mm containing 20.1kg of material to be dried resulting to capacity of the dryer, M of 60.3kg/ batch for the three trays.

### 2.2. Amount of Moisture to Be Removed

The amount of moisture to be removed in kg ( $M_R$ ) is given in Equation (1) as:

$$M_R = M \left( \frac{Q_1 - Q_2}{1 - Q_2} \right) \quad (1)$$

Where, M is dryer capacity per batch (60.3kg),  $Q_1$ =initial moisture content of the product to be dried (88.5%),  $Q_2$ =Maximum desired final moisture content based on experimental results=11%.  $M_R$  is therefore determined to be 53.66kg.

### 2.3. Quantity of Air Required to the Effect Drying in kg ( $Q_a$ )

(Ajisegiriet *al.*, 2006) gave equation 2 as:

$$Q_2 = \left( \frac{M_R}{H_{r2} - H_{r1}} \right) \quad (2)$$

Where,

$H_r$  and  $H_r^2$  are initial and final humidity ratios in kg/kg dry air respectively, and  $M_R$  is determined in equation (1). The average ambient temperature and relative humidity are 31°C for dry bulb temperature, 28°C for wet bulb temperature and 35% for relative humidity. The initial humidity ratio ( $H_{r1}$ ) is determined to be 0.008kg/kg dry air using the psychrometric chart under normal temperature and 101.32kpa barometric pressure. After the heat has been supplied, the temperature of the product rises to 50°C giving the final humidity ratio ( $H_{r2}$ ) as 0.016kg/kg dry air. Substituting, the quantity of air required to effect drying ( $Q_a$ ) is 6,707.5kg.

### 2.4. Volume of Air to Effect Drying in $m^3$ ( $V_a$ )

(Ajisegiriet *al.*, 2006) gave equation 3 as:

$$V_a = \left(\frac{Q_a}{\rho_a}\right) \quad (3)$$

Where,  
 $\rho_a$  is the density of air in kg/m<sup>3</sup> which determined at 0°C to be 1.115kg/m<sup>3</sup> based on properties of common fluid, presented by cornwel, 1978. The volume of air to effect drying is therefore calculated to be 6,015.70 m<sup>3</sup>.

**2.5. Blower Design and Capacity**

The blower serves the purpose of transferring heated air from the heat exchanger to the dryer cabinet. The selection was based on the characteristics of centrifugal fan performance given in the equation below.

$$P = V\rho h \quad (4)$$

Where,  
 P is the power rating of the blower, V is the airflow rate in m<sup>3</sup>/s which is 100.20 m<sup>3</sup>/s,  $\rho$  is the density of air in kg/m<sup>3</sup> which is 1.115kg/m<sup>3</sup>, h=pressure head in m, which is 1m, substituting, the blower capacity is therefore calculated to be 0.150hp which is approximately 0.2hp.

**2.6. Quantity of Heat Required to Effect Drying**

The quantity of heat required to the drying ( $H_r$ ) in kJ is given by:

$$H_r = (M \times H_p) + (H \times M_R) \quad (5)$$

Where,  
 M=dryer capacity per batch (60.3kg),  $H_k = C_T (T_2 - T_1)$ , where,  $C_T$  is the specific heat of the product=4.6 kJ/kg °C and  $T_2 - T_1 = 50 - 31 = 19^\circ\text{C}$ , the value is determined to be 64.4 kJ/kg.  $H_L$ =latent heat of vaporization=1248.1 kJ/kg; and  $M_R$ =amount of moisture to be removed (kg)=53.66kg. Substituting,  $H_r = 70,856.37\text{kJ}$ .

**2.7. Heat Transfer Rate ( $Q_{ht}$ )**

The heat transfer rate ( $Q_{ht}$ ) can be determined (comwel, 1978) as:

$$Q_{ht} = hAT_B \quad (6)$$

Where,  
 h=heat transfer coefficient= $N_u$  k/d with  $N_u$  (Nusselt)= $121.3 = 0.13R_a^{0.33}$   
 With  $R_a = 10^9$ , k as thermal conductivity=0.0305kW/m<sup>2</sup> °C; A=surface area of the heat exchanger=0.4096m<sup>2</sup>, and  $T_B$ =temperature of hot air in the blower=81°C the value of heat transfer rate ( $Q_{ht}$ ) is therefore determined to be 818.15kJ.

**2.8. The Quantity of Heat That Can Be Lost Through the Blower in the Process Is Calculated as**

$$q_1 = \frac{KAT_{BE}}{\delta_K} \quad (7)$$

Where  
 q=quantity of heat lost (kJ), K=thermal conductivity of mild steel=58 W/M.K, A=surface area of the blower=0.10m<sup>2</sup>,

$T_{BE}$ =temperature difference between the hot air in the blower and the environment=81-31=50°C; and  $\delta_k$ =distance=1. The value of  $q_1$  is therefore calculated to be 0.290kJ. The net heat transfer rate ( $Q_{ht}$ ) that will reach the cabinet is ( $Q_{nt} - Q_{ht}$ ) or (818.16-0.290) kJ which is 817.87kJ.

**2.9. Heating Element Design and Capacity**

The heating element serves as the source of heat for the dryer. The design and capacity of the heating element is given by:

$$b = \frac{t}{E} \quad (8)$$

Where,  
 p=power in watts of the electric heating element, E is the energy or quantity of heat required to effect which is 70856.37kg, t is the time of drying in seconds which is 60 seconds substituting, power of the heating element is 1, 180.94j/s  $\equiv$  1.180W.

**2.10. Actual Heat Used to Effect Drying ( $H_D$ )**

The quantity of heat used in effecting drying  $H_D$  in kJ can be determined as in equation (9)

$$H_D = C_a T_c M_R \quad (9)$$

Where;  
 $C_a$ =specific heat capacity of air=1.005kJ/kg °C;  $M_R$ =amount of moisture to be removed=53.66kg, and  $T_c$ =temperature difference in the dryer cabinet=50-31=19°C. The quantity of heat is therefore calculated to be 7550kJ.

*Rate of Mass Transfer*

The mass transfer rate  $Q_{mtr}$  in kg is determined by using equation (10).

$$Q_{mtr} = M_c A_t (H_{r1} - H_{r2}) \times q_2 \quad (10)$$

Where,  
 $M_c$ =mass transfer coefficient of a free water surface=0.083kg/m<sup>2</sup>s,  $A_t$ =total surface area of the three trays=0.336cm<sup>2</sup>, ( $H_{r2} - H_{r1}$ )=(0.016-0.008)=0.008kg/kg dry air, and  $q_2$ =air flow rate=100.26m<sup>3</sup>/s. the mass transfer rate is therefore calculated to be 0.02kg.

*Choice of Materials*

The materials used for the construction of the dryer are easily maintained and repaired, and can be obtained locally at cheaper costs. The physical and chemical properties of the materials are strong enough to withstand heat, vibration, humid air, fatigue and stress without failure during operation. These include:

(a) Mild steel: It has great strength and can be easily welded. It was used for the frame and the body of the machine.

(b) Galvanized sheet metal: This was chosen because of its toughness and ability to conduct and radiate heat. It was used for fabricating the heat exchanger.

(c) Perforated trays: This was made from galvanized sheet metal because of its toughness and ability to conduct and

radiate heat.

(d) Sheet metal (Aluminum): It was chosen because of its high resistance to corrosion. The inside of the cabinet is lined with the sheet in order to reflect heat back to the cabinet.

*Description of the Dryer*

The dryer is cubical in shape with external dimensions of 650mmx650mmx1000mm. The components of the dryer include: the drying chamber, the tray, the insulation, the chimney, the heater, the fan, the plenum chamber, and the thermostat.

*The Drying Chamber*

This is the unit where the actual drying of the wet product is carried out. It consists of insulated cabinet filled with perforated metal trays each of which will contain a thin layer of product, 2cm deep. The internal dimension of the chamber is 620mmx620mmx1000mm. Loading and unloading of the product from the chamber is achieved through the door. The door and the chamber were lagged with fibre of thickness 20mm.

*The Trays*

There are three trays in the cabinet having uniform perforations of 10mm in diameter at the bottom. The dimension of the trays is 620mm x 620mm x20mm. The material of construction is aluminium steel. This is because aluminium steel does not react chemically with products, retains heat very well and is relatively inexpensive. The trays are to be slotted in and out of the drying chamber through the door, with guide rails which were welded to the internal walls of the drying chamber. The gap in between the trays permits air ventilation. Products are kept in thin layers in the trays.

*The Insulator*

The insulation of the dryer to conserve heat energy is very important. The insulation material used was fibre. This is because of its high insulating property, low cost and ready availability. The thickness of the insulator was 20mm. The walls of the dryer were insulated mainly to prevent radiant heat loss, for efficient utilization of energy generated by the heater and promotion of uniform drying of the product in the drying chamber.

*The Chimney*

This is unit through which the air containing moisture that has been removed from the product in the drying chamber is expelled to the atmosphere. The dimension of the chimney is 7.7x8.9cm x 8.9cm. The material of construction was mild steel.

*The Heater*

The heater will supply the energy needed to heat (0.384m<sup>3</sup>/s) of air which will be supplied by the fan to vaporize moisture from the wet product in the drying chamber. A 1500w electric heating element was selected for the drying system.

*The Fan*

The fan provides the energy to move the air mechanically

into the heating unit which is then supplied to the drying chamber. A 0.2hp suction fan was used to achieve this. This type of fan is desired because of its regular air flow characteristics and its low cost.

*The Heat Exchanger*

This is the unit which receives and supplies the heated air to the drying chamber. It has a dimension of 620mm x 620mm x 150mm. it has uniform perforations of 8mm in diameter. The material of construction was galvanized sheet metal and is located between the trays and the heater.

*The Thermostat*

This is a temperature control device which controls the temperature of the air inside the drying chamber. The heater normally causes a difference in relative humidity and temperature of the inlet air and that of the air in the drying chamber. With the heater uncontrolled, there is the tendency of product overheating which leads to a serious damage effect on the quality. So the thermostat is very necessary to control the heater.

*Working Drawings*

The working drawings for the design of the cabinet tray dryer were made as shown in figures 2.

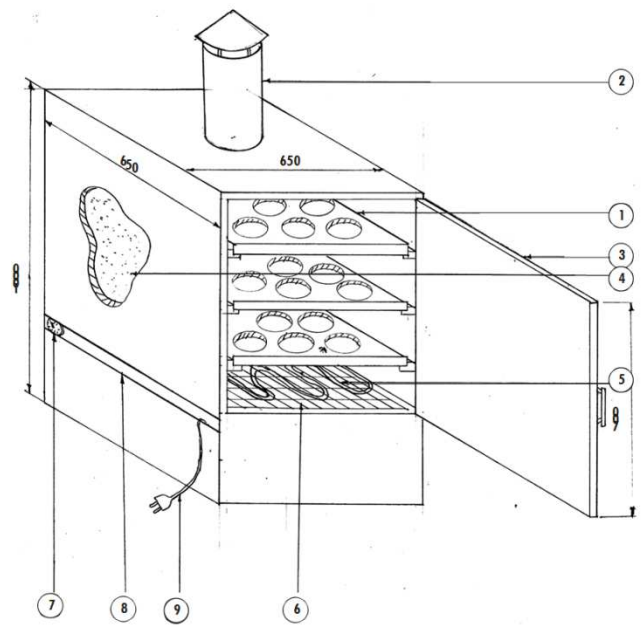

PARTS LIST	
1. Drying Tray	6. Wire Mesh
2. Chimney	7. Thermostat
3. Dryer Door	8. Air Inlet Space
4. Lagging Material	9. Power Cord
5. Heating Coil	

All dimensions in mm (Scale: 1:10)

Figure 2. Isometric view of the cabinet tray dryer.

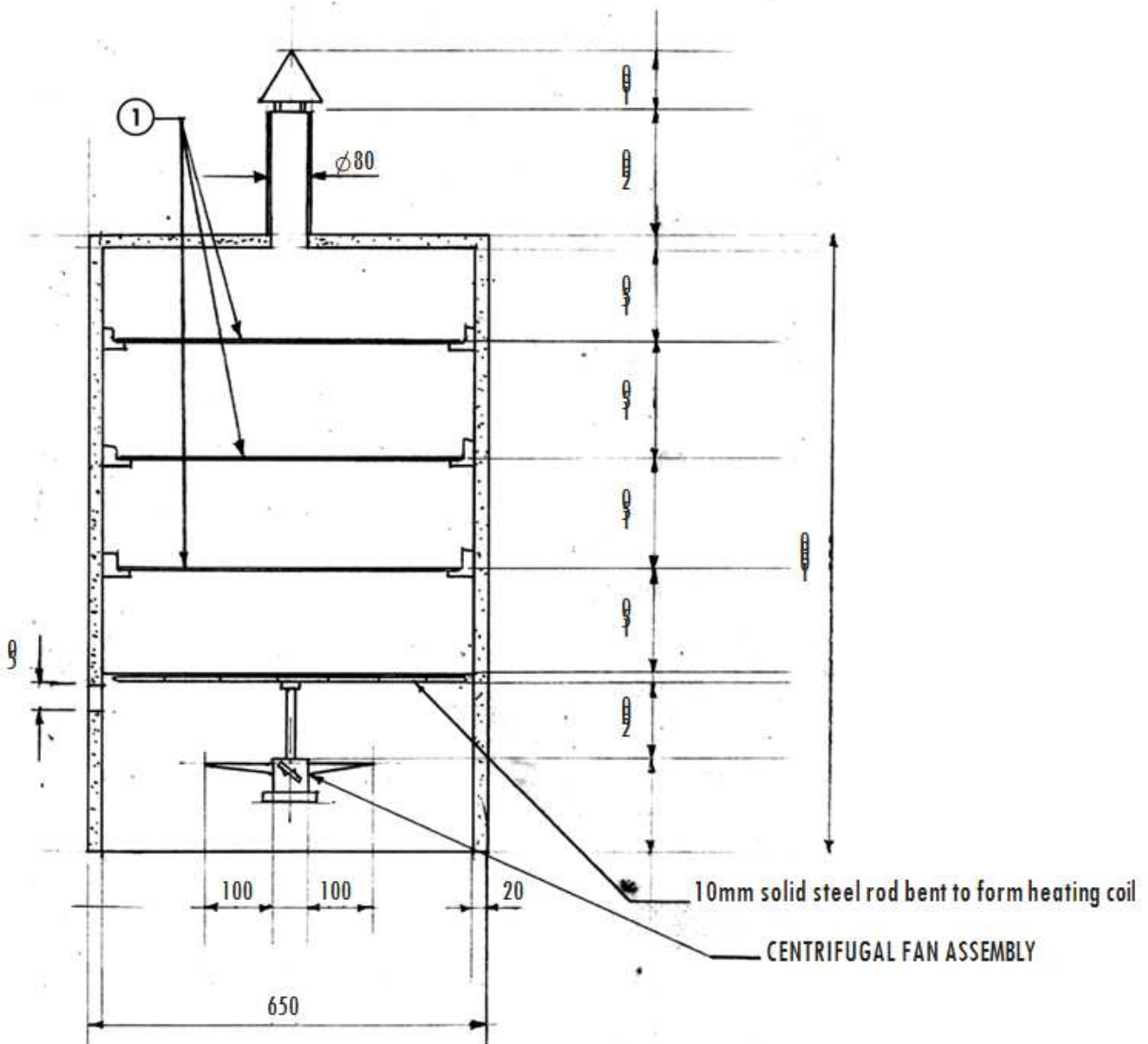
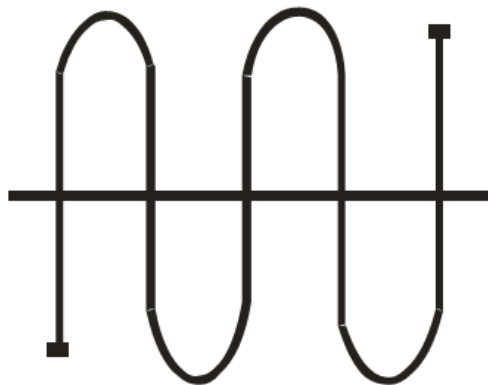

Figure 3. Front sectional view of the cabinet tray dryer.



All dimensions in mm (Scale: 1:10)

Figure 4. Schematic diagram of heating element.

Machine Operation

The machine dries agricultural produce in batches. Each batch takes about 60.3kg on the average for the three trays. The heat exchanger is heated conventionally by the heat generated by the electric heating element. Ambient air enters the exchanger through the exchanger air inlets, make contact with the heated galvanized sheet metal and become hot. The blower sucks the hot air and sends it to the drying products to evenly dry it and the humid air from the dryer is discharged to the atmosphere through the chimney on top of the cabinet.

Test of Machine Performance

Testing being a vital step in the process of machine development was carried out on the constructed electric drying machine in order to determine the performance of the machine, expose defects and area of possible improvement and appreciate the level of success in the research. Thus, it became important to test-run the machine to determine its thermal efficiency and drying rate.

The materials used for testing of the machine include: groundnut, okro, pepper, mercury-in-bulb thermometer, hydrometer, vernier caliper, weighing balance and digital anemometer.

*Heat Generation*

The heat for the drying was generated by an electric heating element of 1.5 kW. The heater was switched on so that the heat would circulate throughout the trays in the dryer. After half an hour the temperature distribution among the trays was determined. This was carried out for three hours at three temperature settings 40, 50 and 60°C. To avoid heat losses through the use of thermometer, a dry bulb thermometer was used for temperature measurements in the drying chamber.

*Air Flow Rates*

The air flow rates were obtained from a centrifugal fan of 0.2hp. The various air flow rate in the three trays were determined experimentally by placing a digital anemometer at the blower air outlet. The machine was run for 30 minutes to stabilize the environmental condition for the drying before introducing the products.

*Temperature, Relative Humidity and Moisture Content measurement*

The temperature of the drying chamber was measured using mercury-in- bulb thermometer, placed approximately at three different points of the three trays. The relative humidity was measured using hydrometer. Moisture content was measured using the standard oven method. The initial moisture content was 90.0%, 88.0%, 87.6% for pepper, okro and groundnut respectively.

*Size of Products*

The crops used for the experiment were purchased from AkpanAndem market, Uyo, AkwaIbom State, Nigeria. The products were washed and the length and width was measured

*(a) Okro*

Fresh Okro whose length ranged from 29mm–97mm and diameter 14–26mm were used for this experiment. The stalk of each fruit was cut into slices of thickness approximately 8-10mm. These were then arranged in the trays such that the flat portions lay horizontally in the trays. For each of the drying operation, the weight per tray was 0.5kg. Also, a weight of 1.0kg was used to determine the effect of tray

loading on the rate of drying.

*(b) Pepper*

Fresh pepper whose length ranged from 25mm–50mm and diameter 10-15mm were used for this experiment. Equal weights of 0.5kg of pepper were then put in each of the trays for each particular drying operation.

*(c) Groundnut*

Fresh groundnut whose length ranged from 8mm–12mm and diameter 5mm-8mm were used for this experiment. Equal weights of 0.5kg of groundnut were then put in each of the trays for the drying operation.

The expressions in equations 11 to 12 were used to calculate the thermal efficiency of the dryer and drying rate.

*Thermal Efficiency of the Dryer*

The thermal efficiency of the dryer  $\eta_c$  is calculated using equation (11).

$$\eta_c = \frac{H_D}{Q_{ht}} \times t \tag{11}$$

Where,

- $\eta_c$ =thermal efficiency of the dryer
- $H_D$ =actual heat used to effect drying
- $Q_{ht}$ =heat transfer rate
- T=time

$$\text{Drying rate, } R_c = \frac{Q_1 - Q_2}{t} \tag{12}$$

### 3. Results and Discussion

The results obtained from the drying of okro, pepper and groundnut are presented in tables 1, 2, 3 and 4 below.

#### 3.1. Drying of Okro

In table 1 below, okro (0.5kg tray loading) of initial moisture content of 87.6% wet basis was reduced to 17.3% wet basis at 50°C after 9 hours of drying. While okro (1.0kg tray loading) of initial moisture content of 88.0% wet basis was reduced to 13.0 wet basis at 50°C after 12hours of drying (table 3) below. This suggested that there is an effect of tray loading in the rate and time of drying.

**Table 1.** Moisture Content, Amount of water removed and drying rate of okro (0.5kg Tray Loading) at 50°C.

*Weight of dry matter=0.052kg*

Time (hr)	Mass of Water Removed (kg)	Drying Rate (kg/hr)	Moisture Content (% db)	Moisture Content (% wb)
0	-	-	706.5	87.6
1	0.156	0.156	454.8	82.0
2	0.092	0.092	306.5	75.4
3	0.046	0.046	332.3	69.9
4	0.042	0.042	164.5	66.2
5	0.031	0.031	114.5	62.2
6	0.023	0.023	77.4	43.6
7	0.018	0.018	48.4	32.6
8	0.012	0.012	29.0	22.5
9	0.005	0.005	21.0	17.3

**Table 2.** Moisture Content, Amount of Water Removed and Drying Rate of okro (1.0kg Tray Loading) at 50°C.

Time (hr)	Mass of water removed (kg)	Drying Rate (kg/hr)	Moisture content (% db)	Moisture content (% wb)
0	-	-	733.3	88.0
1	0.165	0.165	595.8	85.6
2	0.102	0.102	510.8	83.6
3	0.087	0.087	438.3	81.4
4	0.077	0.077	374.2	78.9
5	0.070	0.070	315.8	76.0
6	0.066	0.066	260.8	72.3
7	0.062	0.062	209.2	67.7
8	0.058	0.058	160.8	61.7
9	0.057	0.057	113.3	53.1
10	0.049	0.049	72.5	42.0
11	0.039	0.039	40.0	28.6
12	0.030	0.030	15.0	13.0

### 3.2. Drying of Pepper

**Table 3.** Moisture Content, Amount of Water Removed and Drying Rate of Pepper (0.5kg Tray Loading) at 50°C. Weight of dry matter=0.050.

Time (hr)	Mass of Water Removed (kg)	Drying Rate (kg/hr)	Moisture Content (% db)	Moisture Content (% wb)
0	-	-	900	90
1	0.089	0.089	722	87.8
2	0.053	0.053	616	86.0
3	0.043	0.043	530	84.1
4	0.038	0.038	454	82.0
5	0.035	0.035	384	79.3
6	0.033	0.033	318	76.1
7	0.031	0.031	256	71.9
8	0.028	0.028	200	66.7
9	0.028	0.028	144	59.0
10	0.025	0.025	94	48.5
11	0.020	0.020	54	35.1
12	0.018	0.018	18	15.3

Pepper (0.5kg tray loading) of initial moisture content of 90% wet basis was reduced to 15.3% wet basis at 50°C after 12hours of drying as shown in the table above.

The values obtained shows that no constant rate exists during the drying process at 50°C. This corresponded to the results reported. The absence of a constant rate period implied that in the drying process, internal diffusion of moisture is likely to be the dominant mechanism of moisture movement from the very start of drying. Also, the drying rate decreases as drying progress.

### 3.3. Drying of Groundnut

**Table 4.** Moisture content, Amount of water removed and Drying Rate of Groundnut (0.5kg Tray Loading) at 50°C.

Weight of dry matter=0.061kg

Time (hr)	Mass of water removed (kg)	Dry Rate (kg/hr)	Moisture content (% db)	Moisture content (% wb)
0	-	-	719.7	87.8
1	0.174	0.174	434.4	81.3
2	0.098	0.098	273.8	73.3
3	0.051	0.051	190.2	65.5
4	0.039	0.039	126.2	55.8
5	0.028	0.028	80.3	44.6
6	0.018	0.018	50.8	33.7
7	0.013	0.013	29.5	22.8
8	0.009	0.009	14.8	12.9
9	0.004	0.004	8.2	7.6

Groundnut (0.5kg tray loading) of initial moisture content of 87.8% wet basis was reduced to 7.6% wet basis at 50°C after 9hours of drying as given in the table 4 above.

### 3.4. Variation of Moisture Content with Drying Time

Figure 5 shows the drying curves for the three crops at 50°C. It would be seen that the moisture content decreases with increasing drying time for all the products.

This was evident from the fact that as drying time increases, the rate of moisture removal decreases.

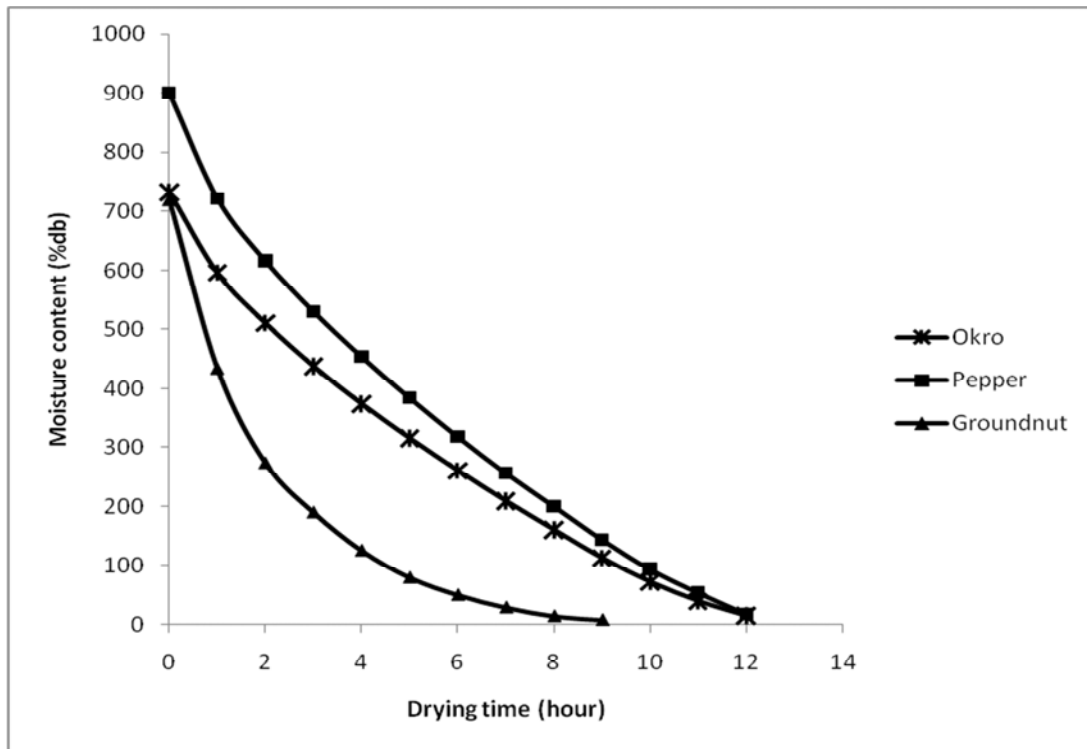

Figure 5. Drying curves for the products at 50°C.

It would also be seen from the figures that there was a wide variation in the moisture contents of the products as drying time increased, but after about 11hrs, there was a very slight variation in the moisture content values of pepper and okro at the temperature used. The reason for this was that as drying reaches an end, the rate at which moisture moves through the product is superseded by the rate of evaporation from the surface. A concentration gradient is established in which the

drying process will be lowered as it proceeds, so that the rate of moisture removal falls even more rapidly than before.

### 3.5. Variation of Drying Rate Against Time

Figure 6 shows the drying rate as drying progresses for the three crops at 0.5kg tray loading. It would be observed that the drying rate decreases with drying time.

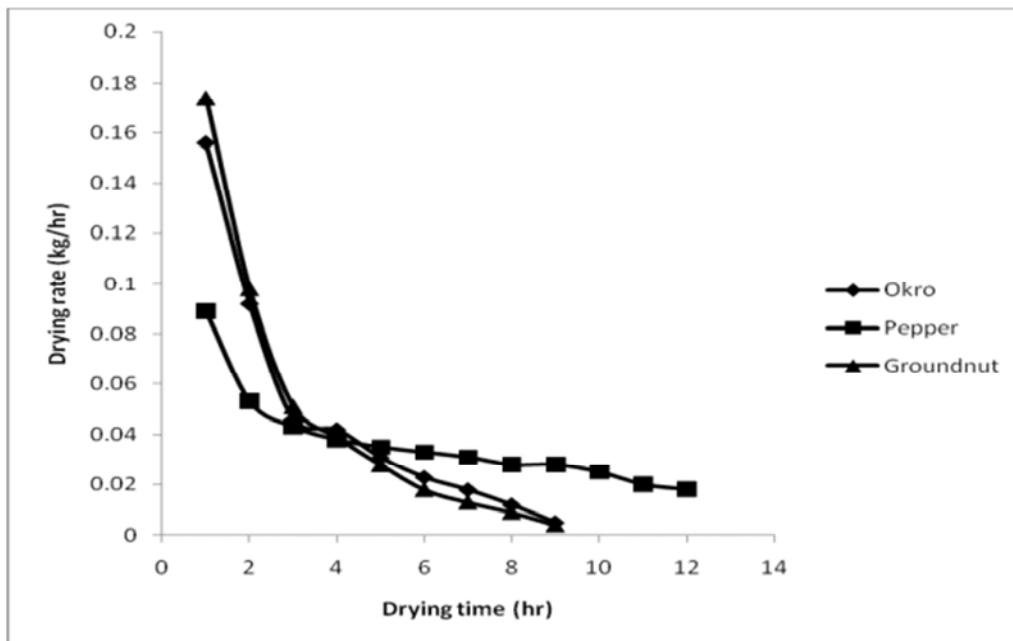

Figure 6. Effect of Drying time on the Drying rate of the Products (0.5kg tray Loading) at 50°C.



This was due to the fact that less moisture was being removed from the product as drying progresses. It was observed from the figure that each crop, the drying rate of okro was the highest because okro was sliced and it has a larger surface area making it easier for drying to take place, while pepper was the lowest. This was due to the fact that pepper had the highest initial moisture content (900% db) and okro had the lowest initial moisture content (706.5% db).

Analysis of variance was performed to ascertain whether the observed differences in the rate of drying of each of the three products at 50°C was statistically significant or was due

to chance variations. The null hypothesis asserts that there is no real difference in the rate of drying of the three products at 50°C, while the alternative hypothesis states that the null Hypothesis is false. At 5% significance level, if the calculated f-value was less than the table f-value, the rate of drying of the three crops at 50°C is not significant and that any difference observed was due to chance variation.

The analysis from table 5 revealed that the calculated F-value was lower than the table F-value at 50°C, hence there was no significant different at 5% level of significance in the drying rates of the three crops.

Table 5. ANOVA Table for the Drying Rate of Products at 50°C.

Variation	Sum of square	Degree of freedom	Means square	F <sub>cal</sub>	F <sub>tab</sub>
Between Treatment	0.002	2	0.001	1.0	3.29
Within treatment	0.035	30	0.001		
Total	0.037	32			

### 3.6. Thermal Efficiency of the Dryer

The thermal efficiency of the dryer  $\eta_c$  is 76.92% and is calculated using equation (11).

## 4. Conclusion

A cabinet dryer was designed and constructed using low price materials that can easily be assessed and maintained by local farmers. The construction was successfully carried out and the machine was tested using okro, pepper and groundnut. The device has a thermal efficiency of 76.9% and drying rate of 0.041kg/hr with average capacity of 60.3kg/batch.

From the design considerations, portability, safety were given due consideration, the drying trays can be slotted in and out through the guide rails and a thermostat to control the temperature in the drying chamber.

## References

- [1] Agboola, S. (1992): Technologies for small-scale storage of grains in Nigeria. Proceedings of 3<sup>rd</sup> CODRI Seminar on food storage, processing and utilization. CODRI 1(1): 22-27.
- [2] Agridem Consultants (1995): Assessment of Post-harvest losses in food crops in Nigeria. A study commissioned by the Federal Department of Agriculture, Abuja. Pp 9-37.
- [3] Ajisegiri, E. S. A., Alababan, B. A and Uche, I. K. (2006). Development of artificial dryer for yam chips. Proceedings of the 7<sup>th</sup> international conference and 28<sup>th</sup> Annual General Meeting of the Nigerian Institution of Agricultural Engineers. ABU, Zaria. 28:348.
- [4] Akulich, P. V. and Miltzer, K. E., (1998). Simulation of Non-Isothermal Moisture Transfer and Stress in wood in Drying. Journal of Food Engineering Physics and Thermophysic, 71, 3, 398-406.
- [5] Cornwel, K., (1978). The Flow of Heat Van Nostrand Reinhold Company Ltd. New York. U.S.A. PP 51.
- [6] FAOSTAT (2004): Food and Agricultural Statistical Database. Faostat.Fao.Org.
- [7] Johnson, P-N.T., Brennan, J. G., Addo-Yobo, P. Y. (1998). Air-drying characteristics of plantain (Musa AAB).Journal of Food Engineering 37, 233-242.
- [8] Kulasiri, D. and Woodhead, I., (2005). On Modeling the Drying of Porous Materials. Analytical solutions to coupled partial differential equation, governing heat and moisture transfer. Mathematical problems in Engineering 3, 275-291.
- [9] Margaris, D. P., and Ghiaus, A. G., (2007). Experimental study of hot air dehydration of sultana grape. Journal of Food Engineering, 73, 75-84.
- [10] Murugesan, K., Thomas, H. R., and Cleall, P. J., (2002). An investigation of the influence of two-stage Drying Conditions on convective Drying of porous materials. International Journal of Numerical Methods for Heat and Fluid Flow, 12, 29-46.
- [11] Sahay, K. M. and Singh, K. K. (1996). Unit Operations of Agricultural processing. Vikas publishing House. PVT Ltd.