

Method for enhancement of power quality at point of common coupling of wind energy system

Jyothilal Nayak Bharothu¹, AbduL Arif²

¹Associate professor of Electrical & Electronics Engineering, Sri Vasavi Institute of Engineering & Technology, Nandamuru, A.P.; India

²Assistant professor of Electrical & Electronics Engineering, Sri Vasavi Institute of Engineering & Technology, Nandamuru, A.P.; India

Email address:

nayakeee@gmail.com (J. Nayak Bharothu), arifabdul76@gmail.com (A. Arif)

To cite this article:

Jyothilal Nayak Bharothu, AbduL Arif. Method for Enhancement of Power Quality at Point of Common Coupling of Wind Energy System. *American Journal of Energy Engineering*. Vol. 1, No. 1, 2013, pp. 11-21. doi: 10.11648/j.ajee.20130101.12

Abstract: In this paper a compensation strategy based on a particular Custom Power System (CUPS) device, the Unified Power Quality Compensator (UPQC) has been proposed. A customized internal control scheme of the UPQC device was developed to regulate the voltage in the WF terminals, and to mitigate voltage fluctuations at grid side. The voltage regulation at WF terminal is conducted using the UPQC series converter, by voltage injection “in phase” with point of common coupling (PCC) voltage. On the other hand, the shunt converter is used to filter the WF generated power to prevent voltage fluctuations, requiring active and reactive power handling capability. The sharing of active power between converters is managed through the common DC link. Therefore the internal control strategy is based on the management of active and reactive power in the series and shunt converters of the UPQC, and the exchange of power between converters through UPQC DC-Link. This approach increases the compensation capability of the UPQC with respect to other custom strategies that use reactive power only. The proposed compensation scheme enhances the system power quality, exploiting fully DC-bus energy storage and active power sharing between UPQC converters, features not present in DVR and D-STATCOM compensators. Simulations results show the effectiveness of the proposed compensation strategy for the enhancement of Power Quality and Wind Farm stability.

Keywords: CUPS, UPQC, PCC, DC Link, Wind Farm, Power Quality Etc

1. Introduction

The location of generation facilities for wind energy is determined by wind energy resource availability, often far from high voltage (HV) power transmission grids and major consumption centers. In case of facilities with medium power ratings, the WF is connected through medium voltage (MV) distribution headlines. A situation commonly found in such scheme is that the power generated is comparable to the transport power capacity of the power grid to which the WF is connected, also known as weak grid connection. The main feature of this type of connections is the increased voltage regulation sensitivity to changes in load. So, the system's ability to regulate voltage at the point of common coupling (PCC) to the electrical system is a key factor for the successful operation of the WF. Also, it is well known that given the random nature of wind resources, the WF generates fluctuating electric power.

These fluctuations have a negative impact on stability and power quality in electric power systems. Moreover, in

exploitation of wind resources, turbines employing squirrel cage induction generators (SCIG) have been used since the beginnings. The operation of SCIG demands reactive power, usually provided from the mains and/or by local generation in capacitor banks. In the event that changes occur in its mechanical speed, i.e. due to wind disturbances, so will the WF active (reactive) power injected (demanded) into the power grid, leading to variations of WF terminal voltage because of system impedance.

This power disturbance propagates into the power system, and can produce a phenomenon known as “flicker”, which consists of fluctuations in the illumination level caused by voltage variations. Also, the normal operation of WF is impaired due to such disturbances. In particular for the case of “weak grids”, the impact is even greater. In order to reduce the voltage fluctuations that may cause “flicker”, and improve WF terminal voltage regulation, several solutions have been proposed. The most common one is to upgrade the power grid, increasing the short circuit power level at the point of common coupling PCC, thus reducing the impact

of power fluctuations and voltage regulation problems.

In recent years, the technological development of high power electronics devices have led to implementation of electronic equipment suited for electric power systems, with fast response compared to the line frequency. These active compensators allow great flexibility in:

Controlling the power flow in transmission systems using Flexible AC Transmission System (FACTS) devices, and

Enhancing the power quality in distribution systems employing Custom Power System (CUPS) devices.

The use of these active compensators to improve integration of wind energy in weak grids is the approach adopted in this work. In this paper we propose and analyze a compensation strategy using an UPQC, for the case of SCIG-based WF, connected to a weak distribution power grid. This system is taken from a real case. The UPQC is controlled to regulate the WF terminal voltage, and to mitigate voltage fluctuations at the point of common coupling (PCC), caused by system load changes and pulsating WF generated power, respectively. The voltage regulation at WF terminal is conducted using the UPQC series converter, by voltage injection “in phase” with PCC voltage. On the other hand, the shunt converter is used to filter the WF generated power to prevent voltage fluctuations, requiring active and reactive power handling capability. The sharing of active power between converters is managed through the common DC link. Simulations were carried out to demonstrate the effectiveness of the proposed compensation approach.

2. Literature Survey

The location of generation facilities for wind energy is determined by wind energy resource availability, often far from high voltage (HV) power transmission grids and major consumption centers [1]. In case of facilities with medium power ratings, the WF is connected through medium voltage (MV) distribution headlines. A situation commonly found in such scheme is that the power generated is comparable to the transport power capacity of the power grid to which the WF is connected, also known as weak grid connection. The main feature of this type of connections is the increased voltage regulation sensitivity to changes in load [2]. The system’s ability to regulate voltage at the point of common coupling (PCC) to the electrical system is a key factor for the successful operation of the WF. Also, it is well known that given the random nature of wind resources, the WF generates fluctuating electric power. These fluctuations have a negative impact on stability and power quality in electric power systems [3].

Moreover, in exploitation of wind resources, turbines employing squirrel cage induction generators (SCIG) have been used since the beginnings. The operation of SCIG demands reactive power, usually provided from the mains and/or by local generation in capacitor banks [4]. In recent years, the technological development of high power elec-

tronics devices has led to implementation of electronic equipment suited for electric power systems, with fast response compared to the line frequency. These active compensators allow great flexibility in: a) controlling the power flow in transmission systems using Flexible AC Transmission System (FACTS) devices, and b) enhancing the power quality in distribution systems employing Custom Power System (CUPS) devices [6]. The use of these active compensators to improve integration of wind energy in weak grids is the approach adopted in this work. In this paper we propose and analyze a compensation strategy using an UPQC, for the case of SCIG-based WF, connected to a weak distribution power grid. This system is taken from a real case [7].

The UPQC is controlled to regulate the WF terminal voltage, and to mitigate voltage fluctuations at the point of common coupling (PCC), caused by system load changes and pulsating WF generated power, respectively. The voltage regulation at WF terminal is conducted using the UPQC series converter, by voltage injection “in phase” with PCC voltage. On the other hand, the shunt converter is used to filter the WF generated power to prevent voltage fluctuations, requiring active and reactive power handling capability. The sharing of active power between converters is managed through the common DC link [8]. The dynamic compensation of voltage variations is performed by injecting voltage in series and active–reactive power in the MV6 (PCC) busbar; this is accomplished by using a unified type compensator UPQC [9]. This transformation allows the alignment of a rotating reference frame with the positive sequence of the PCC voltages space vector. To accomplish this, a reference angle θ synchronized with the PCC positive sequence fundamental voltage space vector is calculated using a Phase Locked Loop (PLL) system. In this work, an “instantaneous power theory” based PLL has been implemented [11].

2.1. Wind Energy

Wind power is the conversion of wind energy into a useful form of energy, such as using wind turbines to make electrical power, windmills for mechanical power, wind pumps for water pumping or drainage, or sails to propel ships. A wind farm is a group of wind turbines in the same location used for production of electricity. A large wind farm may consist of several hundred individual wind turbines, and cover an extended area of hundreds of square miles, but the land between the turbines may be used for agricultural or other purposes. A wind farm may also be located offshore.



Fig.2.1 Wind farm

2.2. Wind Power

Wind is abundant almost in any part of the world. Its existence in nature caused by uneven heating on the surface of the earth as well as the earth's rotation means that the wind resources will always be available. The conventional ways of generating electricity using non renewable resources such as coal, natural gas, oil and so on, have great impacts on the environment as it contributes vast quantities of carbon dioxide to the earth's atmosphere which in turn will cause the temperature of the earth's surface to increase, known as the green house effect. Hence, with the advances in science and technology, ways of generating electricity using renewable energy resources such as the wind are developed. Nowadays, the cost of wind power that is connected to the grid is as cheap as the cost of generating electricity using coal and oil. Thus, the increasing popularity of green electricity means the demand of electricity produced by using non renewable energy is also increased accordingly.

2.2.1. Features of Wind Power Systems

There are some distinctive energy end use features of wind power systems

Most wind power sites are in remote rural, island or marine areas. Energy requirements in such places are distinctive and do not require the high electrical power.

A power system with mixed quality supplies can be a good match with total energy end use i.e. the supply of cheap variable voltage power for heating and expensive fixed voltage electricity for lights and motors.

Rural grid systems are likely to be weak (low voltage 33 KV). Interfacing a Wind Energy Conversion System (WECS) in weak grids is difficult and detrimental to the workers' safety.

There are always periods without wind. Thus, WECS must be linked energy storage or parallel generating system if supplies are to be maintained.

2.3. Power from the Wind

Kinetic energy from the wind is used to turn the generator inside the wind turbine to produce electricity. There are several factors that contribute to the efficiency of the wind turbine in extracting the power from the wind. Firstly, the wind speed is one of the important factors in determining how much power can be extracted from the wind. This is because the power produced from the wind turbine is a function of the cubed of the wind speed. Thus, the wind speed if doubled, the power produced will be increased by eight times the original power. Then, location of the wind farm plays an important role in order for the wind turbine to extract the most available power from the wind.

The next important factor of the wind turbine is the rotor blade. The rotor blades length of the wind turbine is one of the important aspects of the wind turbine since the power produced from the wind is also proportional to the swept area of the rotor blades i.e. the square of the diameter of the

swept area.

Hence, by doubling the diameter of the swept area, the power produced will be fourfold increased. It is required for the rotor blades to be strong and light and durable. As the blade length increases, these qualities of the rotor blades become more elusive. But with the recent advances in fiberglass and carbon-fiber technology, the production of lightweight and strong rotor blades between 20 to 30 meters long is possible. Wind turbines with the size of these rotor blades are capable to produce up to 1 megawatt of power.

The relationship between the powers produced by the wind source and the velocity of the wind and the rotor blades swept diameter is shown below.

$$P_{\text{wind}} = \pi/8 d D^2 V_{\text{wind}}^3 \quad (2.1)$$

The derivation to this formula can be looked up in. It should be noted that some books derived the formula in terms of the swept area of the rotor blades (A) and the air density is denoted as δ .

Thus, in selecting wind turbine available in the market, the best and efficient wind turbine is the one that can make the best use of the available kinetic energy of the wind.

Wind power has the following advantages over the traditional power plants.

- Improving price competitiveness
- Modular installation
- Rapid construction
- Complementary generation
- Improved system reliability and
- Non-polluting

3.

3.1. Weak Grid

The term 'weak grid' is used in many connections both with and without the inclusion of wind energy. It is used without any rigour definition usually just taken to mean the voltage level is not as constant as in a 'stiff grid'. Put this way the definition of a weak grid is a grid where it is necessary to take voltage level and fluctuations into account because there is a probability that the values might exceed the requirements in the standards when load and production cases are considered. In other words, the grid impedance is significant and has to be taken into account in order to have valid conclusions.

Weak grids are usually found in more remote places where the feeders are long and operated at a medium voltage level. The grids in these places are usually designed for relatively small loads. When the design load is exceeded the voltage level will be below the allowed minimum and/or the thermal capacity of the grid will be exceeded. One of the consequences of this is that development in the region with this weak feeder is limited due to the limitation in the maximum power that is available for industry etc.

The problem with weak grids in connection with wind energy is the opposite. Due to the impedance of the grid the amount of wind energy that can be absorbed by the grid at the point of connection is limited because of the upper voltage level limit. So in connection with wind energy a weak grid is a power supply system where the amount of wind energy that can be absorbed is limited by the grid capacity and not e.g. by operating limits of the conventional generation.

3.2. Basic Power Control Idea

The main idea is to increase the amount of wind energy that can be absorbed by the grid at a certain point with minimum extra cost. There exist several options that can be implemented in order to obtain a larger wind energy contribution. These options include:

- Grid reinforcement

- Voltage dependent disconnection of wind turbines

- Voltage dependent wind power production

- Inclusion of energy buffer (storage)

Determination of actual voltage distribution instead of worst case and evaluation if real conditions will be problem
Grid reinforcement increases the capacity of the grid by increasing the cross section of the cables. This is usually done by erecting a new line parallel to the existing line for some part of the distance. Because of the increased cross section the impedance of the line is reduced and therefore the voltage variations as a result of power variations are reduced.

Grid reinforcement increases both the amount of wind energy that can be connected to the feeder and the maximum consumer load of the feeder. Since the line impedance is reduced the losses of the feeder are also reduced. Grid reinforcement can be very costly and sometimes impossible due to planning restrictions. Since grid reinforcement can be very costly or impossible other options are interesting. The simplest alternative is to stop some of the wind turbines when the voltage level is in danger of being exceeded.

This can e.g. be done by the wind turbine controller monitoring the voltage level at the low voltage side of the connection point. At a certain level the wind turbine is cut off and it is then cut in again when the voltage level is below a certain limit. The limits can be recalculated and depends on transformer settings, line impedance and other loads of the feeder. This is a simple and crude way of ensuring that the voltage limits will not be exceeded. It can be implemented at practically no cost but not all the potentially available wind energy is utilized.

A method that is slightly more advanced is to continuously control the power output of the wind turbine in such a way that the voltage limit is not exceeded. This can be done on a wind farm level with the voltage measured at the point of common connection. The way of controlling the power output requires that the wind turbine is capable of controlling the output (pitch or variable speed controlled) and a bit more sophisticated measuring and control equip-

ment, but the amount of wind energy that is dumped is reduced compared to the option of switching off complete wind turbines.

The basic power control idea in the current context of this project is based on the combination on wind turbines and some kind of energy storage. The storage is used to buffer the wind energy that cannot be feed to the grid at the point of connection without violating the voltage limits. Usually the current limit of the grid will not be critical. The energy in the storage can then be fed back to the grid at a later time when the voltage level is lower.

The situations where the voltage level will be high will occur when the consumer load of the grid is low and the wind power production is high. If the voltage level will be critically high depends on the characteristics of the grid (e.g. impedance and voltage control), the minimum load of the consumers, the amount of installed wind power and the wind conditions. The critical issues involved in the design of a power control system are the power and energy capacity, the control bandwidth as well as investment, installation and maintenance cost. The various types of power control systems have different characteristics giving different weights on capacity, investment and maintenance.

Different types of storage can be applied. During the project only pumped storage and batteries has been investigated. Other types of storage include flywheel, super conducting magnetic storage, compressed air and capacitors. These types of storage have not been investigated for several reasons among them cost, capacity and availability.

3.3. Control Strategies

Several different control strategies exist for a power controller with storage. The different control strategies place different weights on voltage and power fluctuations and therefore have different impact on the sizing of the storage capacity and of the power rating. The two main types of control strategies are

- Ones controlling the voltage at the point of common connection or another point in the grid and

- Ones controlling the power for smoothing or capacity increase.

3.4. Basic Problems

3.4.1. Voltage Level

The main problem with wind energy in weak grids is the quasi-static voltage level. In a grid without wind turbines connected the main concern by the utility is the minimum voltage level at the far end of the feeder when the consumer load is at its maximum.

So the normal voltage profile for a feeder without wind energy is that the highest voltage is at the bus bar at the substation and that it drops to reach the minimum at the far end.

The settings of the transformers by the utility are usually so, that the voltage at the consumer closest to the transformer will experience a voltage, that is close to the maximum

value especially when the load is low and that the voltage is close to the minimum value at the far end when the load is high. This operation ensures that the capacity of the feeder is utilized to its maximum. When wind turbines are connected to the same feeder as consumers which often will be the case in sparsely populated areas the voltage profile of the feeder will be much different from the no wind case. Due to the power production at the wind turbine the voltage level can and in most cases will be higher than in the no wind case. As is seen on the figure the voltage level can exceed the maximum allowed when the consumer load is low and the power output from the wind turbines is high. This is what limits the capacity of the feeder.

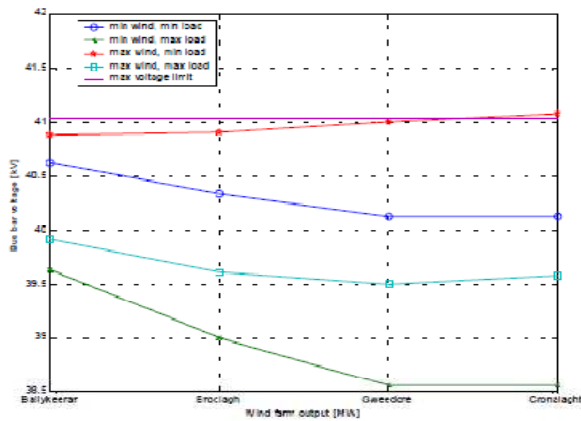

Fig.3.1 Example of voltage for feeder with and without wind power

The voltage profile of the feeder depends on the line impedance, the point of connection of the wind turbines and on the wind power production and the consumer load. For a simple single load case the voltage rise over the grid impedance can be approximated with $\Delta U \cong (R * P + X * Q) / U$ using generator sign convention. This formula indicates some of the possible solutions to the problem with absorption of wind power in weak grids. The main options are either a reduction of the active power or an increase of the reactive power consumption or a reduction of the line impedance.

3.4.2. Power Disturbances

Another possible problem with wind turbines in weak grids are the possible voltage fluctuations as a result of the power fluctuations that comes from the turbulence in the wind and from starts and stops of the wind turbines. As the grids becomes weaker the voltage fluctuations increase given cause to what is termed as flicker. Flicker is visual fluctuations in the light intensity as a result of voltage fluctuations. The human eye is especially sensitive to these fluctuations if they are in the frequency range of 1-10 Hertz. Flicker and flicker levels are defined in IEC1000-3-7.

During normal operation the wind turbulence causes power fluctuations mainly in the frequency range of 1-2 Hertz due to rotational sampling of the turbulence by the blades. This together with the tower shadow and wind shear

are the main contributors to the flicker produced by the wind turbine during normal operation.

The other main contribution to the flicker emission is the cut-in of the wind turbine. During cut-in the generator is connected to the grid via a soft starter. The soft starter limits the current but even with a soft starter the current during cut-in can be very high due to the limited time available for cut-in, especially the magnetization current at cut-in contributes to the flicker emission from a wind turbine.

3.4.2.1. Flicker

Electric power is an essential commodity for most industrial, commercial and domestic processes. As a product, electric power must be of an acceptable quality, to guarantee the correct behavior of the equipment connected to the power distribution system. Low-frequency conducted disturbances are the main factors that can compromise power quality. The IEC 61000-2-1 standard classifies low-frequency conducted disturbances in the following five groups: harmonics and inter harmonics, voltage dips and short supply interruptions, voltage unbalance, power frequency variations and voltage fluctuations or flicker.

Voltage fluctuations are defined as cyclic variations in voltage with amplitude below 10% of the nominal value. Most of the connected equipment is not affected by voltage fluctuations, but these fluctuations may cause changes in the illumination intensity of light sources, known as flicker.

Main sources of flicker

The main sources of flicker are large industrial loads, such as arc furnaces, or smaller loads with regular duty cycles, such as welding machines or electric boilers. However, from the point of view of power generation, flicker as a result of wind turbines has gained attention in recent years. Rapid variations in wind speed produce fluctuating power, which can lead to voltage fluctuations at the point of common coupling (PCC), which in turn generate flicker.

The IEC 61400-21 standard establishes the procedures for measuring and assessing the power quality characteristics of grid-connected wind turbines. The section dedicated to flicker proposes a complex model for calculating the flicker coefficient that characterizes a wind turbine. This coefficient must be estimated from the current and voltage time series obtained for different wind conditions. The wind turbine being tested is usually connected to a medium-voltage network, having other fluctuating loads that may cause significant voltage fluctuations.

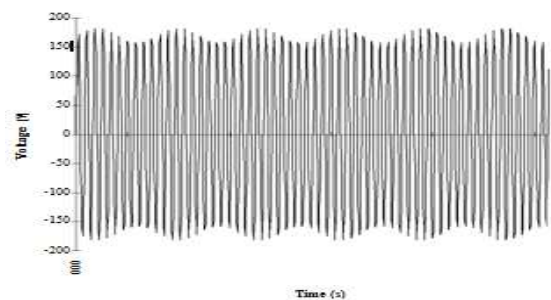

Fig.3.2 Example of voltage flicker

Effects

Flicker is considered the most significant effect of voltage fluctuation because it can affect the production environment by causing personnel fatigue and lower work concentration levels. In addition, voltage fluctuations may subject electrical and electronic equipment to detrimental effects that may disrupt production processes with considerable financial costs.

Other effects of voltage fluctuation include the following:

Nuisance tripping due to misoperation of relays and contactors.

Unwanted triggering of UPS units to switch to battery mode.

Problems with some sensitive electronic equipment, which require a constant voltage (i.e. medical laboratories).

In order to reduce the voltage fluctuations that may cause "flicker" and improve WF terminal voltage regulation, several solutions have been posed. The most common technique is used as custom power device strategy.

3.5. Custom Power Devices

Custom power is a strategy, which is intended principally to convene the requirement of industrial and commercial consumers. The concept of the custom power is tools of application of power electronics controller devices into power distribution system to supply a quality of power, demanded by the sensitive users. These power electronics controller devices are also called custom power devices because through these valuable powers is applied to the customers. They have good performance at medium distribution levels and most are available as commercial products. For the generation of custom power devices VSI is generally used, due to self-supporting of dc bus voltage with a large dc capacitor. The custom power devices are mainly divided into two groups: network reconfiguring type and compensating type.

Custom power devices are classified into two types

- Network reconfiguration type cp devices
- compensating power devices

4.

4.1. Unified Power Quality Conditioner

A Unified Power Quality Conditioner (UPQC) is a device that is similar in construction to a Unified Power Flow Conditioner (UPFC). The UPQC, just as in a UPFC, employs two voltage source inverters (VSIs) that connected to a D.C. energy storage capacitor. One of these two VSIs is connected in series with a.c. line while the other is connected in shunt with the a.c. system.

A UPQC that combines the operations of a Distribution Static Compensator (DSTATCOM) and Dynamic Voltage Regulator (DVR) together.

The function of UPQC includes

- (i) Reactive Power Compensation
- (ii) Voltage Regulation

(iii) Compensation for Voltage sag and swell

(iv) Unbalance Compensation for current and voltage (for 3-phase systems)

(v) Neutral Current Compensation (for 3-phase 4-wire systems)

A UPQC is employed in a power transmission system to perform shunt and series compensation at the same time. A power distribution system may contain unbalance, distortion and even D.C. components. Therefore a UPQC operate, better than a UPFC, with all these aspects in order to provide shunt or series compensation. The UPQC is a relatively new device and not much work has yet been reported on it. Sometimes it has been viewed as combination of series and shunt active filters.

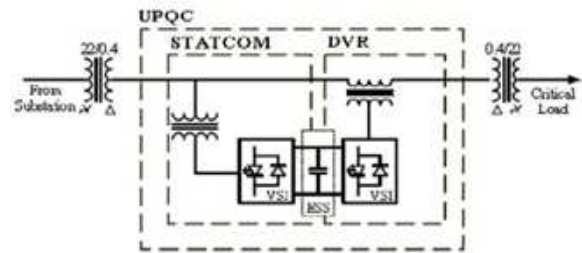

Fig.4.1 Unified power quality conditioner

4.2. Constructional Features of Upqc

UPQC is the integration of series and shunt active filters, connected back-to-back on the dc side, sharing a common DC capacitor as shown in Figure. The series component of the UPQC is responsible for mitigation of the supply side disturbances: voltage sags/swells, flicker, voltage unbalance and harmonics. It inserts voltages so as to maintain the load voltages at a desired level; balanced and distortion free.

The shunt component is responsible for mitigating the current quality problems caused by the consumer: poor power factor, load harmonic currents, load unbalance etc. It injects currents in the ac system such that the source currents become balanced sinusoids and in phase with the source voltages.

This work deals with the review of research work that has been completed so far on this issue. Emphasis has been given on incorporation techniques of UPQC in DG or microgrid system along with their advantages and disadvantages. More DGs such as Photovoltaic or Wind Energy Systems are now penetrating into the grid or microgrid. Again, numbers of nonlinear loads are also increasing. Therefore, current research on capacity enhancement techniques of UPQC to cope up with the expanding DG or microgrid system is also reviewed.

As the UPQC can compensate for almost all existing PQ problems in the transmission and distribution grid, placement of a UPQC in the distributed generation network can be multipurpose. As a part of integration of UPQC in DG systems, research has been done on the following two techniques: DC-Linked and Separated DG-UPQC systems.

4.3. Control Objectives of Upqc

The shunt connected converter has the following control objectives

To balance the source currents by injecting negative and zero sequence components required by the load

To compensate for the harmonics in the load current by injecting the required harmonic currents

To control the power factor by injecting the required reactive current (at fundamental frequency)

To regulate the DC bus voltage.

The series connected converter has the following control objectives

To balance the voltages at the load bus by injecting negative and zero sequence voltages to compensate for those present in the source.

To isolate the load bus from harmonics present in the source voltages, by injecting the harmonic voltages

To regulate the magnitude of the load bus voltage by injecting the required active and reactive components (at fundamental frequency) depending on the power factor on the source side

To control the power factor at the input port of the UPQC (where the source is connected. Note that the power factor at the output port of the UPQC (connected to the load) is controlled by the shunt converter.

5.

5.1. System Description

Fig.5.1 depicts the power system under consideration in this study. The WF is composed by 36 wind turbines using squirrel cage induction generators, adding up to 21.6MW electric power. Each turbine has attached fixed reactive compensation capacitor banks (175kVAr), and is connected to the power grid via 630KVA 0.69/33kV transformer.

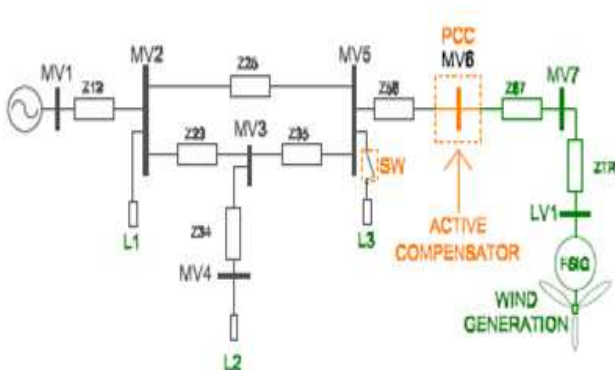

Fig.5.1 Study case power system

This system is taken from and represents a real case. The ratio between short circuit power and rated WF power, give us an idea of the “connection weakness”. Thus considering that the value of short circuit power in MV6 is $SSC \approx$

120MV A this ratio can be calculated

$$r = \frac{S_{sc}}{P_{wf}} \approx 5.5 \quad (5.1)$$

Values of $r < 20$ are considered as a “weak grid” connection.

5.2. Turbine Rotor and Associated Disturbances Model

The power that can be extracted from a wind turbine is determined by the following expression:

$$p = \frac{1}{2} \rho \pi R^2 V^3 C_p \quad (5.2)$$

Where is ρ air density, R the radius of the swept area, v the wind speed, and C_p the power coefficient. For the considered turbines (600kW) the values are $R = 31.2$ m, $\rho = 1.225$ kg/m³ and C_p calculation is taken from. Then, a complete model of the WF is obtained by turbine aggregation; this implies that the whole WF can be modeled by only one equivalent wind turbine, whose power is the arithmetic sum of the power generated by each turbine according to the following equation:

$$P_T = \sum_{i=1, \dots, 36} P_i \quad (5.3)$$

Moreover, wind speed v in (1) can vary around its average value due to disturbances in the wind flow. Such disturbances can be classified as deterministic and random. The firsts are caused by the asymmetry in the wind flow “seen” by the turbine blades due to “tower shadow” and/or due to the atmospheric boundary layer, while the latter are random changes known as “turbulence”. For our analysis, wind flow disturbance due to support structure (tower) is considered, and modeled by a sinusoidal modulation superimposed to the mean value of v . The frequency for this modulation is $3.N_{rotor}$ for the three-bladed wind turbine, while its amplitude depends on the geometry of the tower. In our case we have considered a mean wind speed of 12m/s and the amplitude modulation of 15%. The effect of the boundary layer can be neglected compared to those produced by the shadow effect of the tower in most cases. It should be noted that while the arithmetic sum of perturbations occurs only when all turbines operate synchronously and in phase, this is the case that has the greatest impact on the power grid (worst case), since the power pulsation has maximum amplitude. So, turbine aggregation method is valid.

5.3. Model of Induction Generator

For the squirrel cage induction generator the model available in Matlab/Simulink Sim Power Systems libraries is used. It consists of a fourth-order state-space electrical model and a second-order mechanical model.

5.4. Dynamic Compensator Model

The dynamic compensation of voltage variations is per-

formed by injecting voltage in series and active–reactive power in the MV6 (PCC) busbar; this is accomplished by using an unified type compensator UPQC. In Fig.5.2 we see the basic outline of this compensator; the busbars and impedances numbering is referred to Fig.5.1. The operation is based on the generation of three phase voltages, using electronic converters either voltage source type (VSI– Voltage Source Inverter) or current source type (CSI– Current Source Inverter). VSI converters are preferred because of lower DC link losses and faster response in the system than CSI. The shunt converter of UPQC is responsible for injecting current at PCC, while the series converter generates voltages between PCC and U1, as illustrated in the phasor diagram of Fig.5.3. An important feature of this compensator is the operation of both VSI converters (series and shunt) sharing.

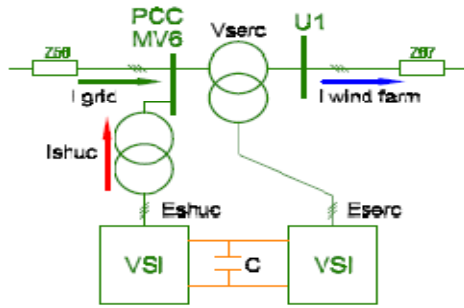

Fig.5.2 Block diagram of UPQC

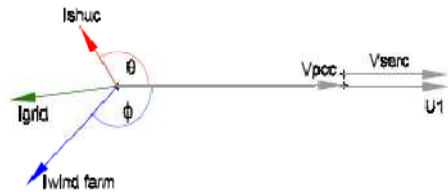

Fig.5.3 Phasor diagram of UPQC

The same DC–bus, which enables the active power exchange between them. We have developed a simulation model for the UPQC based on the ideas taken from. Since switching control of converters is out of the scope of this work, and considering that higher order harmonics generated by VSI converters are outside the bandwidth of significance in the simulation study, the converters are modeled using ideal controlled voltage sources. Fig.5.4 shows the adopted model of power side of UPQC. The control of the UPQC, will be implemented in a rotating frame dq0 using Park’s transformation.

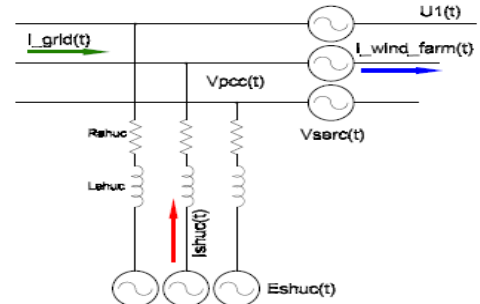

Fig.5.4 Power stage compensator model Ac side

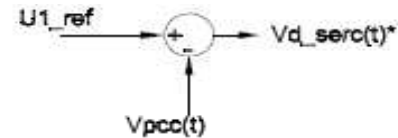

Fig.5.5 Series compensator controller

Where $f_i=a, b, c$ represents either phase voltage or currents, and $f_i=d, q, 0$ represents that magnitudes transformed to the d_{q0} space. This transformation allows the alignment of a rotating reference frame with the positive sequence of the PCC voltages space vector. To accomplish this, a reference angle synchronized with the PCC positive sequence fundamental voltage space vector is calculated using a Phase Locked Loop (PLL) system. In this work, an “instantaneous power theory” based PLL has been implemented. Under balance steady-state conditions, voltage and currents vectors in this synchronous reference frame are constant quantities. This feature is useful for analysis and decoupled control.

5.5. Upqc Control Strategy

The UPQC serial converter is controlled to maintain the WF terminal voltage at nominal value (see U1 bus-bar in Fig.5.4), thus compensating the PCC voltage variations. In this way, the voltage disturbances coming from the grid cannot spread to the WF facilities. As a side effect, this control action may increase the low voltage ride-through (LVRT) capability in the occurrence of voltage sags in the WF terminals. Fig.5.5 shows a block diagram of the series converter controller. The injected voltage is obtained subtracting the PCC voltage from the reference voltage, and is phase–aligned with the PCC voltage (see Fig.5.3). On the other hand, the shunt converter of UPQC is used to filter the active and reactive power pulsations generated by the WF. Thus, the power injected into the grid from the WF compensator set will be free from pulsations, which are the origin of voltage fluctuation that can propagate into the system. This task is achieved by appropriate electrical currents injection in PCC. Also, the regulation of the DC bus voltage has been assigned to this converter. Fig.5.6 shows a block diagram of the shunt converter controller.

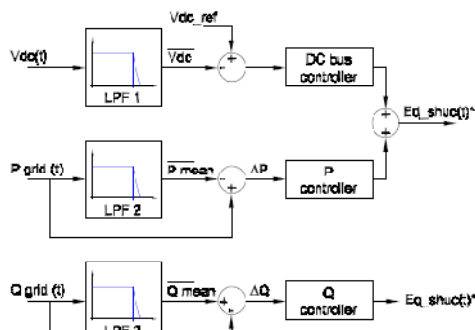

Fig.5.6 Shunt compensator controller

This controller generates both voltages commands $E_{d-shuc*}$ and $E_{q-shuc*}$ based on power fluctuations P and Q, respectively. Such deviations are calculated subtracting the mean power from the instantaneous power measured in PCC.

The mean values of active and reactive power are obtained by low-pass filtering, and the bandwidth of such filters are chosen so that the power fluctuation components selected for compensation, fall into the flicker band as stated in IEC61000- 4-15 standard. In turn, $E_{d-shuc*}$ also contains the control action for the DC-bus voltage loop. This control loop will not interact with the fluctuating power compensation, because its components are lower in frequency than the flicker-band. The powers P_{shuc} and Q_{shuc} are calculated in the rotating reference frame, as follows:

$$P_{shuc}(t) = \frac{3}{2} V_d^{PCC}(t) \cdot I_d^{shuc}(t) \quad (5.4)$$

$$Q_{shuc}(t) = -\frac{3}{2} V_d^{PCC}(t) \cdot I_q^{shuc}(t)$$

Ignoring PCC voltage variation, these equations can be written as follows.

$$P_{shuc}(t) = k'_p \cdot I_{d-shuc}(t) \quad (5.5)$$

$$Q_{shuc}(t) = k'_q \cdot I_{q-shuc}(t)$$

Taking in consideration that the shunt converter is based on a VSI, we need to generate adequate voltages to obtain the currents in (6). This is achieved using the VSI model proposed sin [10], leading to a linear relationship between the generated power and the controller voltages. The resultant equations are:

$$P_{shuc}(t) = k_p'' \cdot E_{d-shuc*}(t) \quad (5.6)$$

$$Q_{shuc}(t) = k_q'' \cdot E_{q-shuc*}(t)$$

P and Q control loops comprise proportional controllers, while DC-bus loop, a PI controller. In summary, in the proposed strategy the UPQC can be seen as a “power buffer”, leveling the power injected into the power system grid.

The Fig.5.7 illustrates a conceptual diagram of this mode of operation. It must be remarked that the absence of an

external DC source in the UPQC bus, forces to maintain zero-average power in the storage element installed in that bus. This is accomplished by a proper design of DC voltage controller. Also, it is necessary to note that the proposed strategy cannot be implemented using other CUPS devices like D-STATCOM or DVR. The power buffer concept may be implemented using a D-STATCOM, but not using a DVR. On the other hand, voltage regulation during relatively large disturbances cannot be easily coped using reactive power only from D-STATCOM; in this case, a DVR device is more suitable.

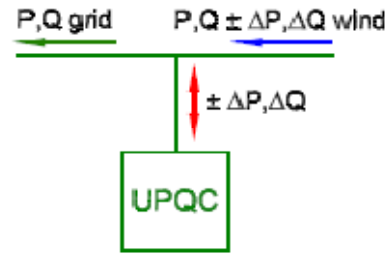

Fig.5.7 Power buffer concept

6. Simulation Results

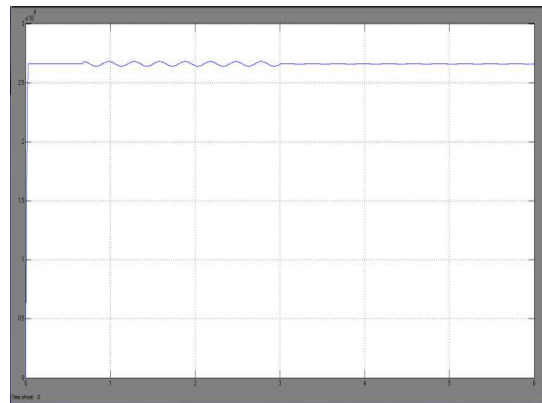

Fig.6.1 Wind farm terminal voltages

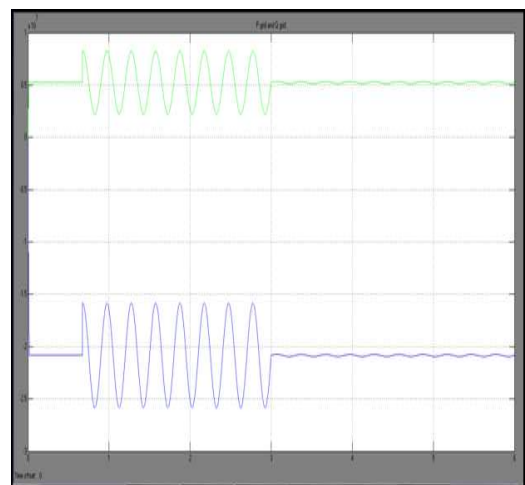

Fig.6.2 Active and reactive power demand at power grid side

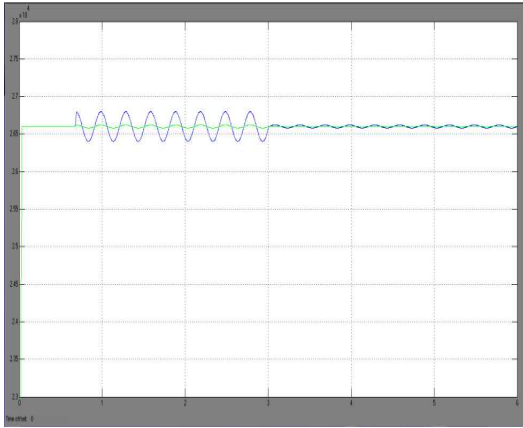

Fig.6.3 Voltage at point of common coupling

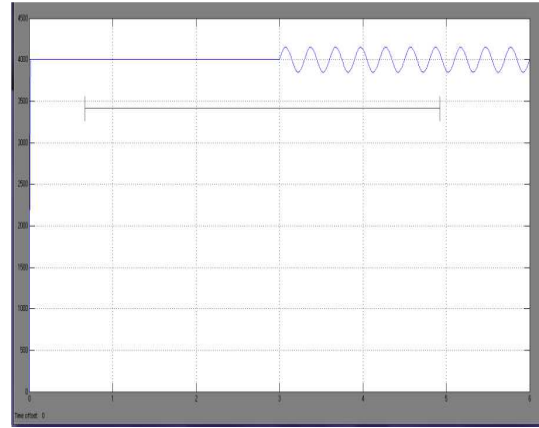

Fig.6.7 Voltage of the capacitor in the DC-Bus

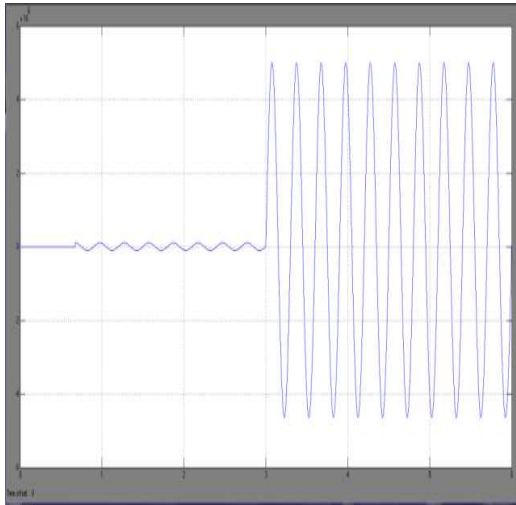

Fig.6.5 Power of the capacitor in the voltage bus

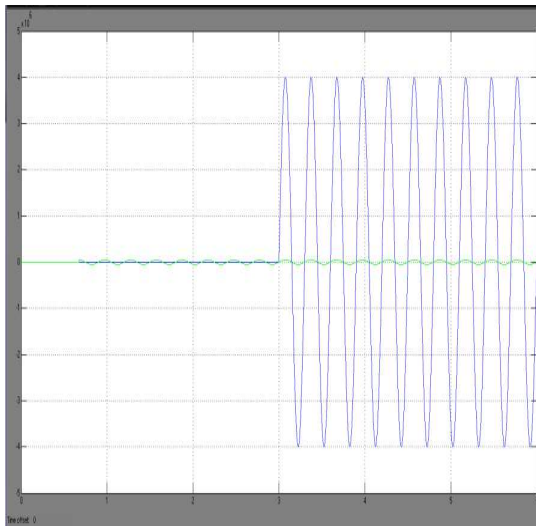

Fig.6.6 DC- Bus voltage

7. Conclusion

The main work of the paper has been carried to show that by using custom power devices like UPQC it is possible to regulate the voltage in the wind farm terminals, and to mitigate voltage fluctuations in distribution systems. The UPQC which can be used at the PCC for improving power quality is modelled and simulated using proposed control strategy and the performance is compared by applying it to a distribution system.

In this paper, a new compensation strategy implemented using an UPQC type compensator was presented, to connect SCIG based wind farms to weak distribution power grid. The proposed compensation scheme enhances the system power quality, exploiting fully DC-bus energy storage and active power sharing between UPQC converters, features not present in DVR and D-STATCOM compensators.

The simulation results show a good performance in the rejection of power fluctuation due to “tower shadow effect” and the regulation of voltage due to a sudden load connection. So, the effectiveness of the proposed compensation approach is demonstrated in the study case. In future work, performance comparison between different compensator types will be made.

Acknowledgements

I Thank to our Institute Executive directors Mr.T Sai kumar & Mr.D Baba for providing creative environment for this work. Also I am very much thankful to our Institute principal Dr. K Ramesh for his kind permission and encouragement to write research paper. I would like to extend my heartfelt thanks to my colleagues. And finally I am very much obliged to my respected parents who inspiring me around the clock.

References

- [1] M. F. McGranaghan, R. C. Dugan, and H. W. Bety, *Electrical Power Systems Quality*. New York: McGraw-Hill, 1996.

- [2] T. A. Short, *Electric Power Distribution Handbook*. Boca Raton, FL: CRC, 2004.
- [3] P. Heine, "Voltage sag distributions caused by power system faults," *IEEE Trans. Power Syst.*, vol. 18, no. 4, pp. 1367–1373, Nov. 2003.
- [4] D. S. Dorr, M. B. Hughes, T. M. Gruzs, R. E. Jurewicz, and J. L. McClaine, "Interpreting recent power quality surveys to define the electrical environment," *IEEE Trans. Ind. Appl.*, vol. 33, no. 6, pp. 1480–1487, Nov./Dec. 1997.
- [5] T. S. Key and J.-S. Lai, "Comparison of standards and power supply design options for limiting harmonic distortion in power systems," *IEEE Trans. Ind. Appl.*, vol. 29, no. 4, pp. 688–695, Jul./Aug. 1993.
- [6] A. Domijan, Jr., A. Montenegro, A. J. F. Keri, and K. E. Mattern, "Custom power devices: An interaction study," *IEEE Trans. Power Syst.*, vol. 20, no. 2, pp. 1111–1118, May 2005.
- [7] H. Fujita and H. Akagi, "The unified power quality conditioner: The integration of series- and shunt-active filters," *IEEE Trans. Power Electron.*, vol. 13, no. 1, pp. 315–322, Mar. 1998.
- [8] H. Fujita, Y. Watanabe, and H. Akagi, "Control and analysis of a unified power flow controller," in *Proc. IEEE/PELS PESC*, 1998, pp. 805–811.
- [9] M. Rahman, M. Ahmed, R. Gutman, R. J. O'Keefe, R. J. Nelson, and J. Bian, "UPFC application on the AEP system: Planning
- [10] M.P. P'álsson, K. Uhlen, J.O.G. Tande. "Large-scale Wind Power Integration and Voltage Stability Limits in Regional Networks"; *IEEE* 2002. p.p. 762–769
- [11] P. Ledesma, J. Usaola, J.L. Rodriguez "Transient stability of a fixed speed wind farm" *Renewable Energy* 28, 2003 pp.1341–1355
- [12] P. Rosas "Dynamic influences of wind power on the power system". Technical report RISØR-1408. Ørsted Institute. March 2003.
- [13] R.C. Dugan, M.F. McGranahan, S. Santoso, H.W. Beaty "Electrical Power Systems Quality" 2nd Edition McGraw-Hill, 2002. ISBN 0-07- 138622-X
- [14] P. Kundur "Power System Stability and Control" McGraw-Hill, 1994. ISBN 0-07-035958-X
- [15] N. G. Hingorani y L. Gyugyi. "Understanding FACTS". IEEE Press; 2000.
- [16] Z. Saad-Saoud, M.L. Lisboa, J.B. Ekanayake, N. Jenkins and G. Strbac "Application of STATCOM's to wind farms" *IEE Proc. Gen. Trans. Distrib.* vol. 145, No. 5; Sept. 1998
- [17] T. Burton, D. Sharpe, N. Jenkins, E. Bossanyi "Wind Energy Handbook" John Wiley & Sons, 2001. ISBN 0-471-48997-2.
- [18] Ghosh, G. Ledwich "Power Quality Enhancement Using Custom Power Devices" Kluwer Academic Publisher, 2002. ISBN 1-4020-7180- 9
- [19] Schauder, H. Mehta "Vector analysis and control of advanced static VAR compensators" *IEE PROCEEDINGS-C*, Vol.140, No.4, July 1993.
- [20] E.M. Sasso, G.G. Sotelo, A.A. Ferreira, E.H. Watanabe, M. Aredes, P.G. Barbosa, "Investigac, ˆao dos Modelos de Circuitos de Sincronismo Trif´asicos Baseados na Teoria das Potˆencias Real e Imagin´aria Instantaneas (p-PLL e q-PLL)", In: *Proc. (CDROM) of the CBA 2002 – XIV Congresso Brasileiro de Automtica*, pp. 480-485, Natal RN, Brasil, 1-4, Sep. 2002
- [21] International Electro technical Commission"INTERNATIONAL STANDAR IEC 61000-4-15: Electromagnetic compatibility (EMC) Part 4: Testing and measurement techniques Section 15: Flickermeter Functional and design specifications." Edition 1.1 2003
- [22] H.Akagi, E.H.Watanabe, M.Aredes "Instantaneous power theory an applications to power conditioning", John Wiley & Sons, 2007. ISBN 978-0-470-1